



# Sailor

# Sailor

INSTRUKTIONSBOG FOR  
SAILOR RE2100

INSTRUCTION BOOK FOR  
SAILOR RE2100

INSTRUKTIONSBUCH FÜR  
SAILOR RE2100

INSTRUCTIONS POUR  
SAILOR RE2100

INSTRUCCIONES PARA  
SAILOR RE2100



A/S S. P. RADIO · AALBORG · DENMARK

## CONTENTS

1. INTRODUCTION
  - 1.1. GENERAL DESCRIPTION
  - 1.2. TECHNICAL DATA
  - 1.3. CONTROLS
  - 1.4. PRINCIPLE OF OPERATION AND BLOCK DIAGRAM
  
2. INSTALLATION
  - 2.1. MOUNTING POSSIBILITIES
  - 2.2. DIMENSIONS AND DRILLING PLAN
  - 2.3. ELECTRICAL CONNECTION AND ASSEMBLING
  
3. SERVICE
  - 3.1. MAINTENANCE
  - 3.2. ALIGNMENT INSTRUCTIONS
  - 3.3. PROPOSAL FOR NECESSARY TEST EQUIPMENT
  - 3.4. TROUBLE SHOOTING
  - 3.5. PERFORMANCE CHECK
    - 3.5.1. PERFORMANCE CHECK OF DISPLAY AND KEYBOARD
    - 3.5.2. PERFORMANCE CHECK OF RECEIVER
    - 3.5.3. PERFORMANCE CHECK OF EXCITER
  - 3.6. MODULE PERFORMANCE CHECK
    - 3.6.1. MODULE PERFORMANCE CHECK OF RECEIVER UNIT
    - 3.6.2. MODULE PERFORMANCE CHECK OF FRONT END UNIT
    - 3.6.3. MODULE PERFORMANCE CHECK OF SYNTHESIZER UNIT
    - 3.6.4. MODULE PERFORMANCE CHECK OF EXCITER UNIT
    - 3.6.5. MODULE PERFORMANCE CHECK OF PROCESSOR UNIT
    - 3.6.8. MODULE PERFORMANCE CHECK OF POWER UNIT
  - 3.7. ADJUSTMENT PROCEDURE
    - 3.7.1. ADJUSTMENT PROCEDURE FOR FRONT END AND RECEIVER UNIT
    - 3.7.2. ADJUSTMENT PROCEDURE FOR SYNTHESIZER UNIT
    - 3.7.3. ADJUSTMENT PROCEDURE FOR EXCITER UNIT
    - 3.7.4. ADJUSTMENT PROCEDURE FOR POWER UNIT
  - 3.8. NECESSARY ADJUSTMENT AND CHECK AFTER REPAIR
  - 3.9. FUNCTION CHECK
  - 3.10. SELECTION AND DESCRIPTION OF THE SERVICE PROGRAMMES

- 4. MECHANICAL DESCRIPTION
- 4.1. MECHANICAL DISASSEMBLING AND MODULE LOCATION
  
- 5. CIRCUIT DESCRIPTION AND SCHEMATIC DIAGRAMS
- 5.1. RECEIVER UNIT (MODULE 1)
- 5.2. RECEIVER FRONT END (MODULE 2)
- 5.3. SYNTHESIZER UNIT (MODULE 3)
- 5.4. EXCITER UNIT (MODULE 4)
- 5.5. PROCESSOR UNIT (MODULE 5)
- 5.6. KEYBOARD UNIT (MODULE 6)
- 5.7. DISPLAY UNIT (MODULE 7)
- 5.8. POWER UNIT (MODULE 8)
- 5.9. INTERCONNECTION CABLE DIAGRAM
  
- 6. MICROTELEPHONE INSTALLATION
- 6.1. SPECIAL INSTALLATION WITH 2 MICROTELEPHONES
- 6.2. SPECIAL INSTALLATION WITH 3 MICROTELEPHONES
  
- 7. PARTS LIST

## CONTENTS

1. INTRODUCTION
- 1.1. GENERAL DESCRIPTION
- 1.2. TECHNICAL DATA
- 1.3. CONTROLS
- 1.4. PRINCIPLE OF OPERATION AND BLOCK DIAGRAM

## 1. INTRODUCTION

SAILOR Compact HF SSB RE2100 is the control unit in SAILOR Compact HF SSB Programme 2000.

SAILOR Compact HF SSB Programme 2000 is a powerful, advanced, high technology short wave communication system which is extremely easy to operate.

It has been developed on the basis of S. P. Radio's many years of experience with short wave communication equipment.

It has the same high reliability as all SAILOR equipment is known for.

It is extremely easy to operate:

1. Select frequency.
2. Make your call when the tune lamp has been extinguished.

It has been constructed so that it fits in with the other units in the SAILOR Compact Programme 2000.

### **SAILOR HF SSB PROGRAMME 2000 CONSISTS OF THE FOLLOWING UNITS:**

RE2100: Control unit with integral receiver and exciter.

T2130: 250W PEP SSB transmitter with integral power supply for RE2100. Supply voltage 24V.

AT2110: 250W PEP aerial coupler for use outdoors.

N2160: 12V DC power supply for T2130.

N2161: 110/220/240 AC, 50 Hz power supply for T2130.

## 1.1. GENERAL DESCRIPTION

SAILOR HF SSB RE2100 is an all solid state constructed microcomputer controlled SSB short wave telephony receiver and exciter.

SAILOR HF SSB RE2100 covers the frequency range from 100 kHz to 30 MHz in receive mode and from 1.6 MHz to 30 MHz in transmit mode.

SAILOR HF SSB RE2100 can operate in both simplex and semi-duplex.

SAILOR HF SSB RE2100 includes all ITU channels from 4 MHz to 22 MHz.

SAILOR HF SSB RE2100 includes channel scanning facilities.

SAILOR HF SSB RE2100 includes 100 quick select frequency pairs.

SAILOR HF SSB RE2100 has continuous tuning in receive mode.

SAILOR HF SSB RE2100 has clarifier function  $\pm 150$  Hz in 10 Hz steps.

SAILOR HF SSB RE2100 is fully synthesized and has a high stability reference oscillator (TCXO).

SAILOR HF SSB RE2100 has an easy to read display with red light figures.

SAILOR HF SSB RE2100 has a push-button keyboard offering an attractive tactile feeling and a safe finger-guide in the metal front. The keyboard is fitted with night-illumination of the lettering.

SAILOR HF SSB RE2100 has one key operation of the distress frequency 2182 kHz.

SAILOR HF SSB RE2100 has integral two tone alarm signal generator in accordance with SOLAS.

SAILOR HF SSB RE2100 has a special serial input (SP-BUS) enabling RE2100 to communicate with other units.

## 1.2. TECHNICAL DATA

(complies with SOLAS, ITU, CEPT, MPT, DOC, FTZ, KSR, FCC)

### GENERAL

<u>Frequency Range:</u>	Receiver:	100 kHz to 30 MHz
	Transmitter:	1.6 MHz to 30 MHz
<u>Modes:</u>	J3E (USB/LSB), R3E and H3E (AM)	
<u>Channel Capacity:</u>	100 user defined quick-select channels and ITU defined channels in the maritime bands. Each channel contains both RX and TX frequency and mode settings.	
<u>Scanning Facilities:</u>	10 scanning programmes, each able to contain 128 pairs of frequencies.	
<u>Distress Call:</u>	Quick selection of 2182 kHz Built-in two tone alarm: 1300 Hz and 2200 Hz with a duration of 45 secs.	
<u>Operating Temperature Range:</u>	-15°C to +55°C	
<u>Frequency Stability:</u>	Better than 1.3 ppm	
<u>Primary Voltage:</u>	24V DC -10% +30%	
<u>Current Drain:</u>	Receiver (standby)	0.9A
	Transmit voice	7A
	Transmit two-tone	13A
<u>Aerials:</u>	from 7 - 15 m	

### TRANSMITTER T2130

<u>Power Output:</u>	250W PEP +/-1.4 dB (T2130/I 240W PEP max.)
<u>Intermodulation:</u>	better than 32 dB below PEP
<u>Spurious Emission:</u>	better than 67 dB below PEP
<u>Harmonics:</u>	better than 43 dB below PEP or better than 67 dB below PEP with aerial coupler AT2110
<u>Carrier Suppression:</u>	better than 46 dB below PEP
<u>Audio Response:</u>	350 Hz to 2700 Hz at -6 dB

### RECEIVER RE2100

<u>Receive System:</u>	Double conversion super heterodyne 1st IF 70 MHz. 2nd 10.73 MHz
<u>Selectivity:</u>	J3E (SSB) 350 Hz to 2700 Hz at -6 dB H3E (AM) +3.3 kHz at -6 dB

## 1.2. TECHNICAL DATA cont.:

<u>Sensitivity:</u>	J3E (SSB) <10 dB/uV for 20 dB SINAD H3E (AM) <24 dB/uV for 20 dB SINAD
<u>Spurious and IF Rejection:</u>	better than -70 dB
<u>Cross Modulation:</u>	better than 90 dB/uV (CEPT method of test)
<u>Desensitization:</u>	better than 100 dB/uV (CEPT method of test)
<u>AGC:</u>	less than 2 dB audio level change from 10 dB/uV to 80 dB/uV. Fast attack, slow release time.
<u>Intermodulation:</u>	better than 90 dB/uV (CEPT method of test)
<u>Spurious Emission:</u>	better than 1 nW into dummy aerial
<u>Clarifier:</u>	<u>±</u> 150 Hz in steps of 10 Hz
<u>Squelch:</u>	Voice activated, opens for SINAD >6 dB
<u>Audio Power:</u>	5 Watt, 8 ohm, less than 10% distortion 10 Watt, 4 ohm, less than 10% distortion

### AERIAL COUPLER AT2110

<u>Power:</u>	250W PEP
<u>Aerial:</u>	7 - 15 m
<u>Temperature Range:</u>	-25°C to +70°C
<u>Tuning Time:</u>	Typically less than 2 secs (learn mode typ. 30 secs)

### ACCESSORIES

<u>Loudspeaker:</u>	H2054 see special brochure H2074 see special brochure
<u>Power Supplies:</u>	N2160, 12V DC -10% +30% to 24V DC max. output current 18 Amps.  N2161, 110V, 115V, 220V, 245V AC, 50-60 Hz to 29V DC max. output current 20 Amps. Automatic change-over.
<u>Weight:</u>	RE2100: 4.5 kg T2130: 14 kg AT2110: 4.5 kg

### Dimensions:



### 1.3. CONTROLS



Volume control and on/off switch for the mains.

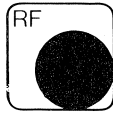

Manual RF gain control.



Tunes the receive frequency down.



Tunes the receive frequency up.



Switches between clarifier (10 Hz steps) and tune of receive frequency.



Selects receive functions or converts a channel number to the corresponding frequency.

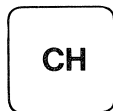

Selects channel functions.

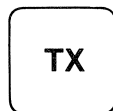

Selects transmit functions or converts a channel number to the corresponding frequency.



Selects the built-in dummy load in the aerial coupler.



Transmits the distress signal when pressed together with TEST ALARM.



Selects the distress frequency 2182 kHz.



Acoustic check of the alarm signal generator.

DIM

Reduces/increases the display light or switches on/off the display and keyboard panel.

SQ

Switches the squelch function on/off.

MODE

Selects modulation type J3E, R3E, H3E and J3E lower side band.

SC

Selects the scan programme.

SC

ADD

Adds a new channel to the scanning table.

SC

DEL

Deletes a channel from the scanning table.

7

Digits from 1 to 0.

ENT

Terminates the keying-in sequence, stops the alarm signal, stops the scanning, and stops the TX tuning.

.

Sets the decimal point for the frequency in kHz.

CH

(Digits 0-99)

ADD

Adds the RX/TX frequency to the channel number.

CH

(Digits 0-99)

DEL

Deletes the RX/TX frequency from the channel

## 1.4. PRINCIPLE OF OPERATION

SAILOR Compact HF SSB RE2100 is the control unit in SAILOR Compact HF SSB Programme 2000. It contains following circuits.

### PROCESSOR UNIT

This unit controls all modules and operate as interface between the user and the radio (keyboard, display). Nearly all communication from the microprocessor to the modules is done on an internal serial bus (SPI).

The unit holds all memory, and all user defined memory is in an EEPROM, so even when supply voltage is removed, the contents of the memory is preserved. If the supply voltage to the RE2100 gets too low, the display will show error 20, and the performance of the RE2100 will be reduced.

There is also an external serial bus (SP-Bus). This bus is used to communicate with other units in the SAILOR Compact HF SSB Programme 2000, e.g. the transmitter T2130.

The microprocessor also generates the alarm tones (1300 Hz, 2100 Hz).

### DISPLAY UNIT

This unit contains the display and the field strength meter.

### SYNTHESIZER UNIT

This unit contains all frequency generating parts.

There is only one reference oscillator which is a temperature compensated crystal oscillator (TCXO) with a frequency of 10.73 MHz.

Both receiver and exciter are using two LO-signals. These signals are generated in two separate PLL's, one having output frequencies from 70 MHz to 100 MHz and the other having output frequencies of 59.27 MHz and 80.73 MHz. The synthesizer which covers from 70 to 100 MHz is a fractional synthesizer with a resolution of 10 Hz.

The other synthesizer is a conventional synthesizer. It has two output frequencies, one for lower sideband 80.73 MHz and another for upper sideband 59.27 MHz.

### RECEIVER FRONT END

This unit contains input protection circuit, input filters, mixer and 70 MHz IF.

The input filter is a mixture of lowpass, highpass and bandpass filter to obtain max. performance in the entire band from 100 kHz to 30 MHz.

The mixer is a FET mixer with a high level LO-injection to give the mixer good high signal quality. The mixer is followed by a 70 MHz bilitic quartz filter with a bandwidth of 15 kHz.

### RECEIVER UNIT

This unit contains all necessary circuits to convert a 70 MHz IF signal to an audio signal.

It starts with the second mixer which is a FET mixer. From the mixer the signal is fed to a high order monolithic quartz filter, one for AM and one for SSB. The type of filter is selected from the microprocessor.

#### 1.4. PRINCIPLE OF OPERATION cont.:

From the filter the signal is fed to the 10.73 MHz IF amplifier. The gain of this amplifier is regulated from the AGC amplifier. The regulated IF amplifier is followed by a ceramic filter to reduce the wideband noise. The signal is from here fed to the demodulator, which can operate as an SSB detector or an AM detector controlled from the microprocessor. The detector is followed by a filter circuit. In AM mode the filter width is from 70 Hz to 3000 Hz, and in SSB mode the filter is from 300 Hz to 3000 Hz. From here the AF signal passes some switches and then it is amplified in three AF amplifiers, one for the microtelephone earpiece, one for the 0 dBm output, and an amplifier with volume control for the AF signal to the AF power amplifier in T2130.

The signal from the AF filters is also fed to the voice controlled squelch. This contains a limiting amplifier, a frequency to voltage converter, and a threshold amplifier. On/off switching of the squelch is controlled by the microprocessor.

In scan mode the squelch is used to detect if there is signal on the channel in question.

#### EXCITER UNIT

This unit contains all necessary circuits to generate an SSB/AM signal in the frequency range from 1.6 - 30 MHz.

It starts with a compressor and AF amplifier.

The AF signal is fed to the balanced modulator to produce a double sideband signal on 10.73 MHz.

The DSB signal is fed to the LSB filter where only the lower sideband passes through. The LSB signal is fed to a step attenuator, which is controlled from the microprocessor. From the step attenuator the signal is fed to the first mixer, and the frequency is converted to 70 MHz. If 59.27 MHz LO-signal is used, the signal will be lower sideband. If 80.73 MHz LO-signal is used, the signal will be upper sideband. From the mixer the signal is fed to an amplifier, 70 MHz crystal filter and an amplifier. From the amplifier the signal is fed to the second mixer which converts the frequency from 1.6 MHz to 30 MHz.

After the mixer a lower side signal is converted to an upper sideband signal, and an upper sideband signal is converted to a lower sideband signal. The output of the mixer is fed to the power unit.

#### POWER UNIT

This unit contains the final amplifying and filtering of the RF signal, and produces all necessary supply voltages for the modules in RE2100.

The signal from exciter unit is first amplified, then filtered in a 30 MHz lowpass filter and then amplified to a level of approx. 2 mW.

The input voltages from T2130 is +18V and 9V. These voltages passes through seven series regulators to produce the necessary supply voltages to RE2100. A special +15V for the exciter is controlled from the microprocessor, so when the transmitter has not been used for two minutes, it is switched off to reduce the power consumption in standby.

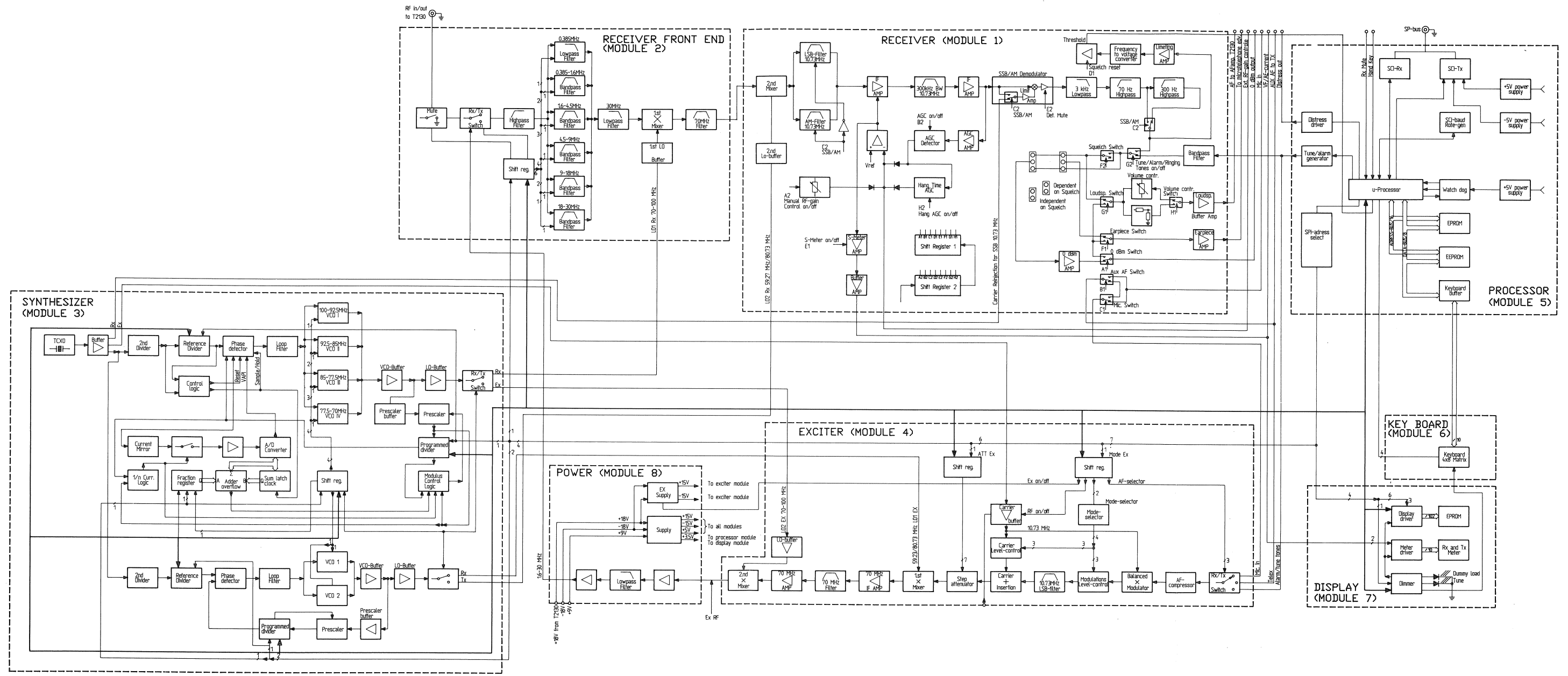



## CONTENTS

- 2. INSTALLATION
- 2.1. MOUNTING POSSIBILITIES
- 2.2. DIMENSIONS AND DRILLING PLAN
- 2.3. ELECTRICAL CONNECTION AND ASSEMBLING
- 2.4. MANUAL TUNE-UP PROCEDURE (USED IF THE AUTOMATIC SYSTEM  
IS FAULTY)





## 2. INSTALLATION

### 2.1. MOUNTING POSSIBILITIES

#### TABLETOP AND DECKHEAD

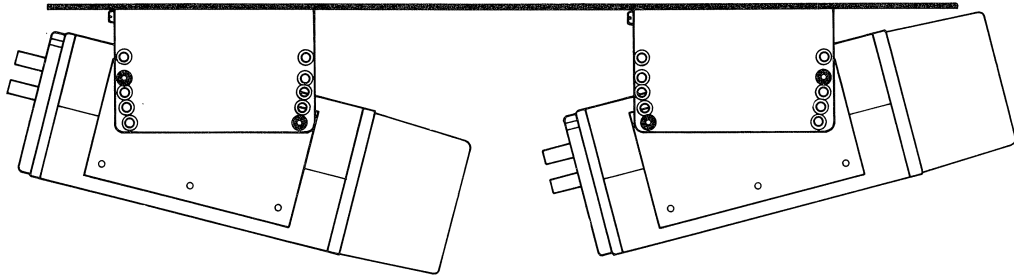
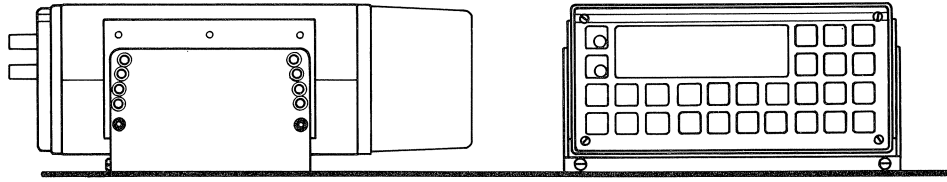

Mounting bracket H2055 which offers the same possibilities for the loudspeakers H2054 and H2074.

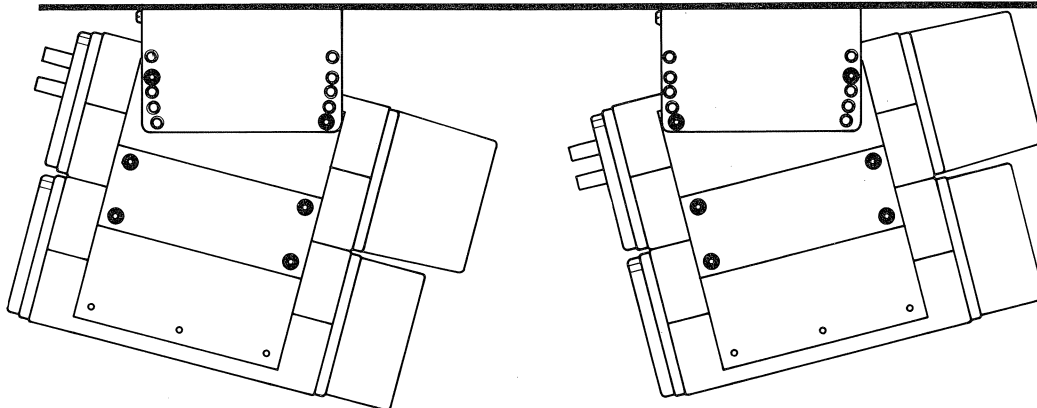
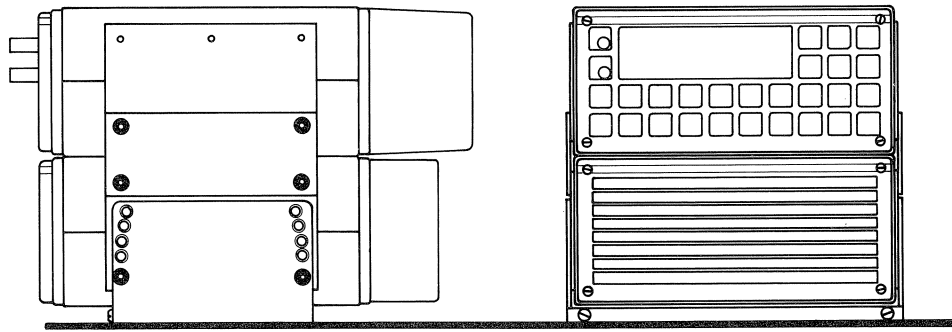

Mounting kit H2068 and H2055

RE2100 / R2122  
4-0-25933 4-0-25931  
4-0-25932

2.1. MOUNTING POSSIBILITIES cont.:

BULKHEAD AND CONSOLE

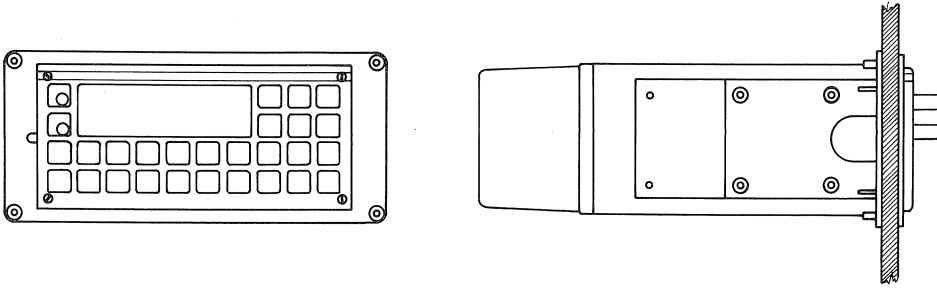

Mounting kit H2063 which offers the same possibilities for the loudspeakers H2054 and H2074.

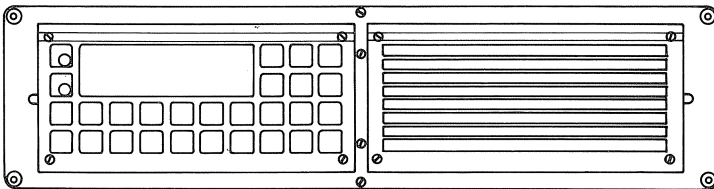

Mounting kit H2062 or

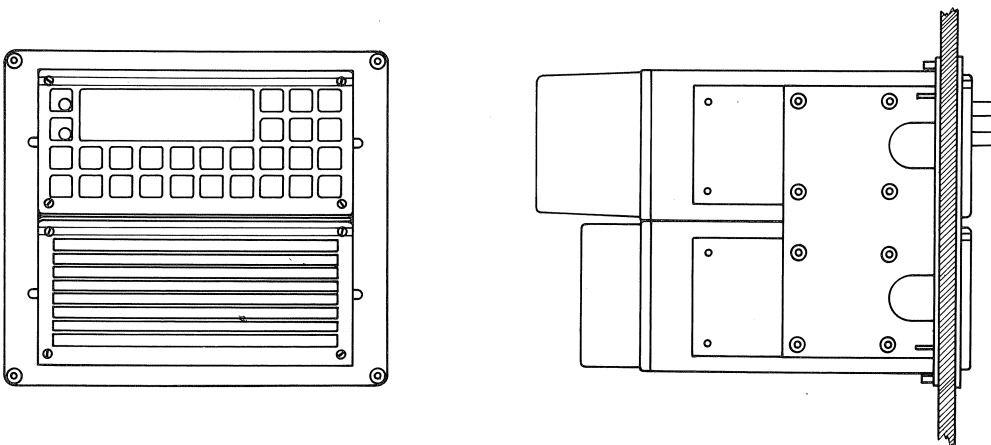

Mounting kit H2064.

IN CONJUNCTION WITH OTHER SAILOR EQUIPMENT

Look up the INSTALLATION section for the SAILOR unit in question.

## 2.2. DIMENSIONS AND DRILLING PLAN

### UNIVERSAL MOUNTING BRACKET H2055

permits a wide variety of installation possibilities, such as tabletop, bulkhead or deckhead. For other possibilities such as console installation, the SAILOR 19" rack or all units in the Compact programme assembled on the bulkhead, see special information concerning installation of the Compact programme.

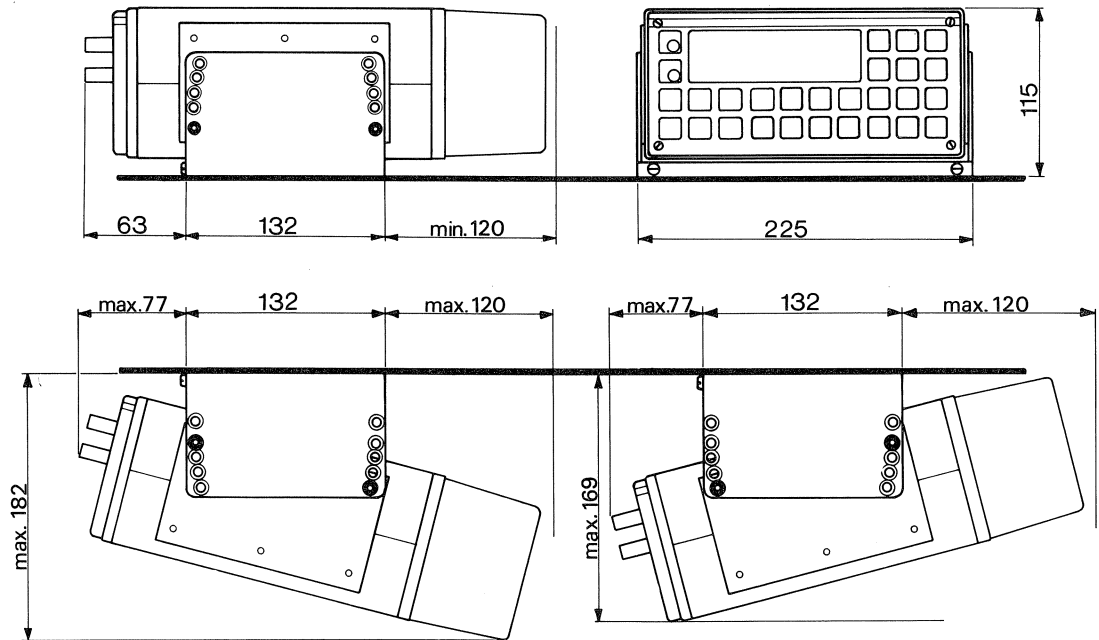

### WEIGHT

Mounting kit H2055:	1.5 kg
Loudspeaker H2054:	5.5 kg
Loudspeaker H2074:	4.0 kg
HF SSB RE2100:	4.5 kg

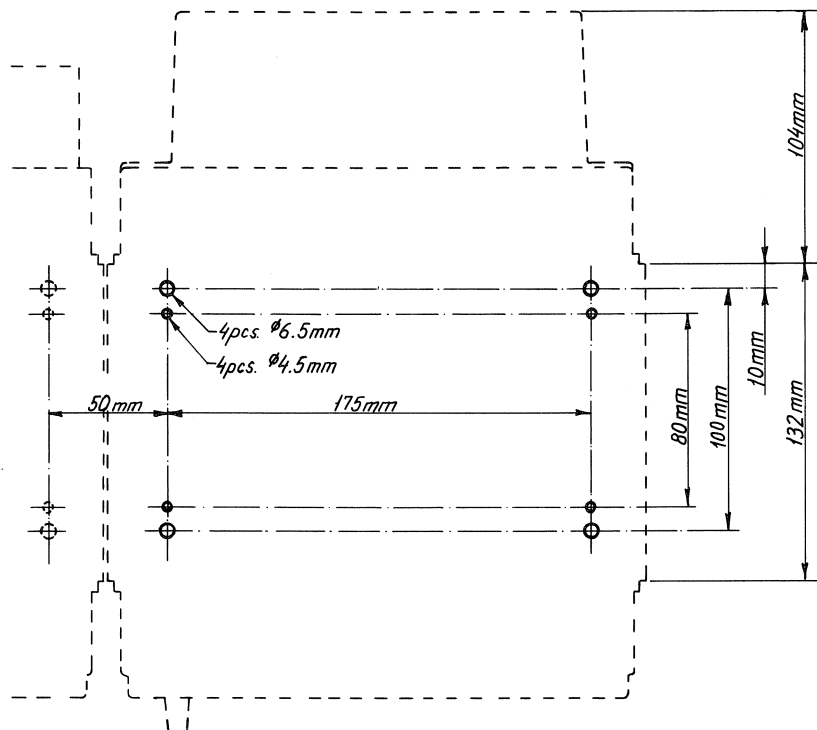

2.2. DIMENSIONS AND DRILLING PLAN cont.:

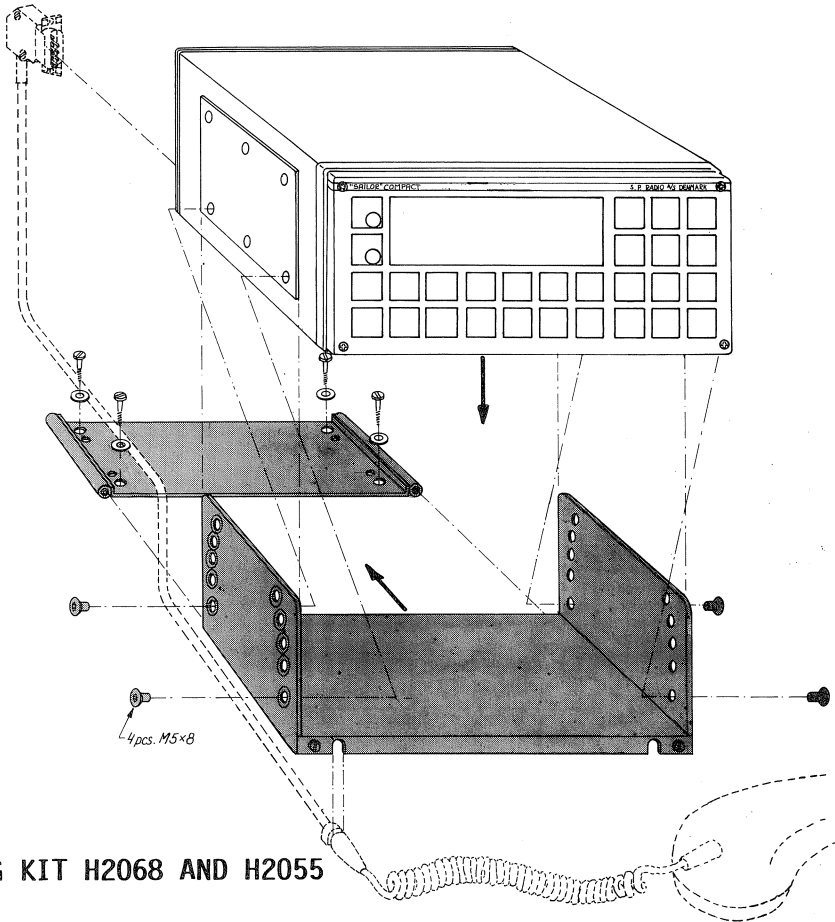

MOUNTING KIT H2068 AND H2055

RE2100  
4-0-25934 4-0-25928  
4-0-25929

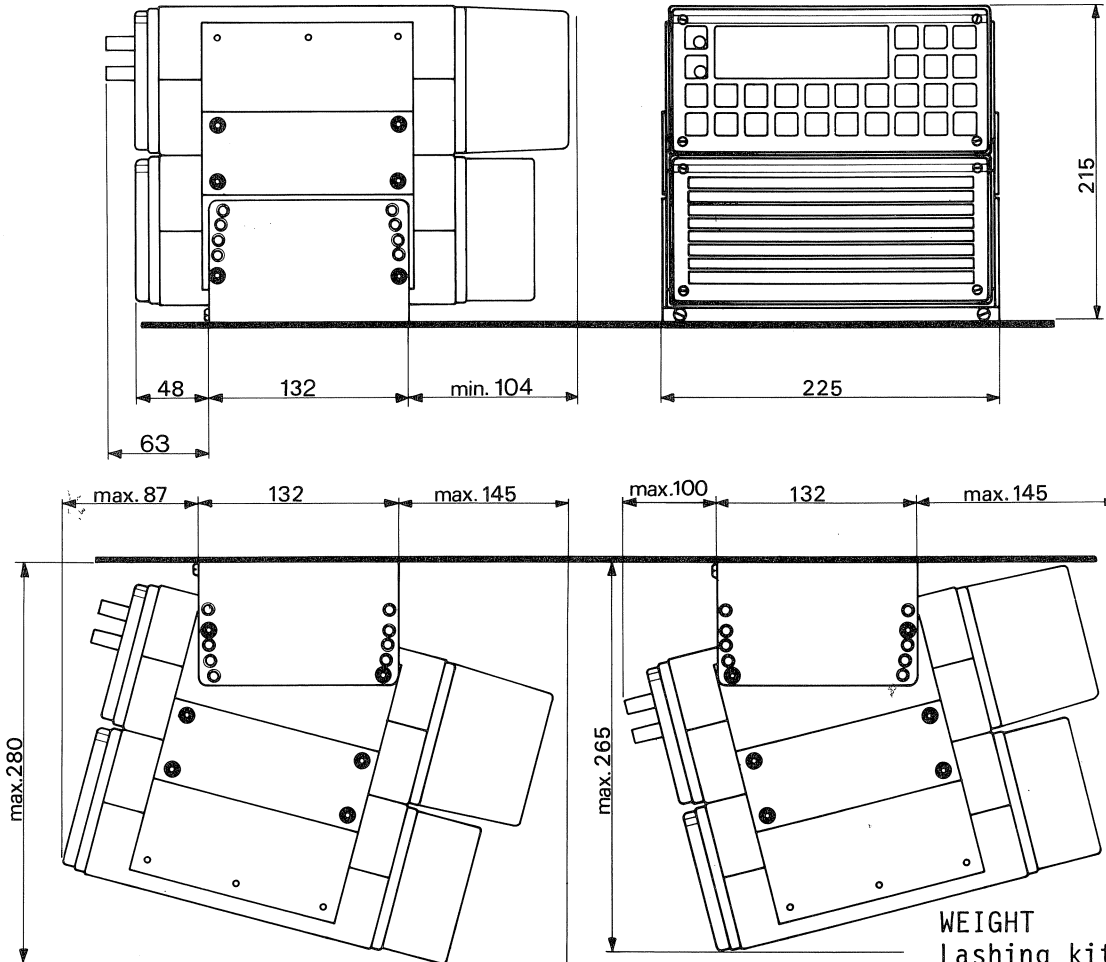

WEIGHT	
Lashing kit H2068:	1.5 kg
Mounting kit H2055:	1.5 kg
Loudspeaker H2054:	5.5 kg
Loudspeaker H2074:	4.0 kg
HF SSB RE2100:	4.5 kg

## 2.2. DIMENSIONS AND DRILLING PLAN cont.:

### MOUNTING KIT H2063

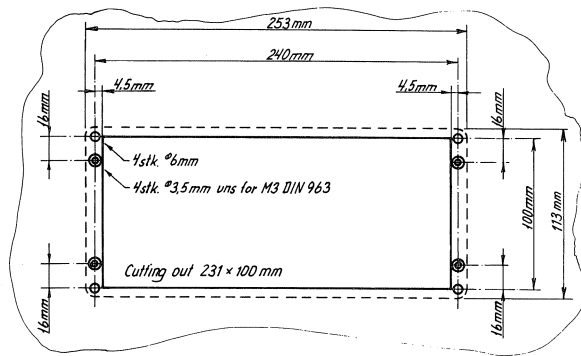
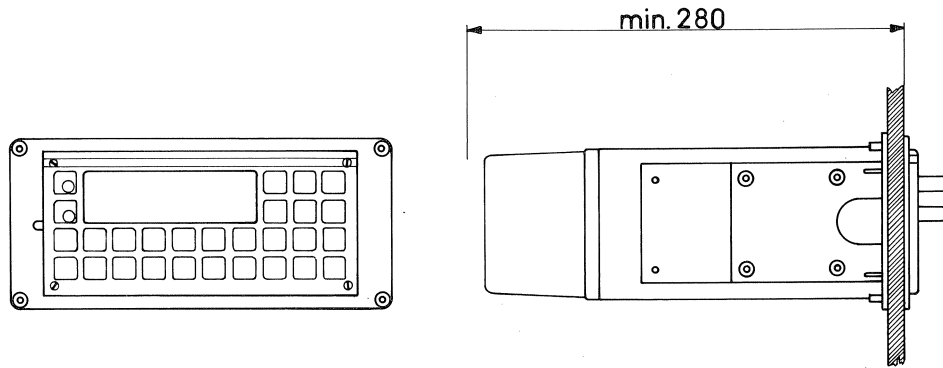

Free distance must be kept to allow free air circulation ambient temperature max. 40°C.

#### WEIGHT

Mounting kit H2063:	1.0 kg
Loudspeaker H2054:	5.5 kg
Loudspeaker H2074:	4.0 kg
HF SSB RE2100:	4.5 kg

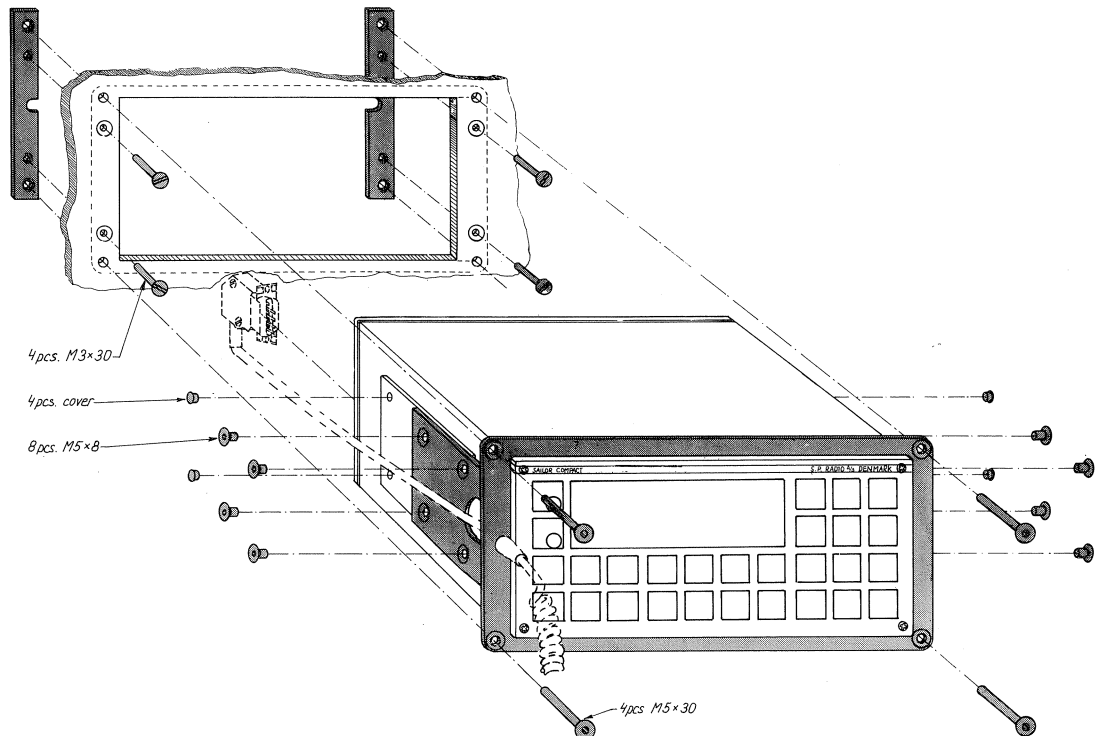

RE2100  
4-0-25935  
4-0-24703  
4-0-25936

2.2. DIMENSIONS AND DRILLING PLAN cont.:

MOUNTING KIT H2064

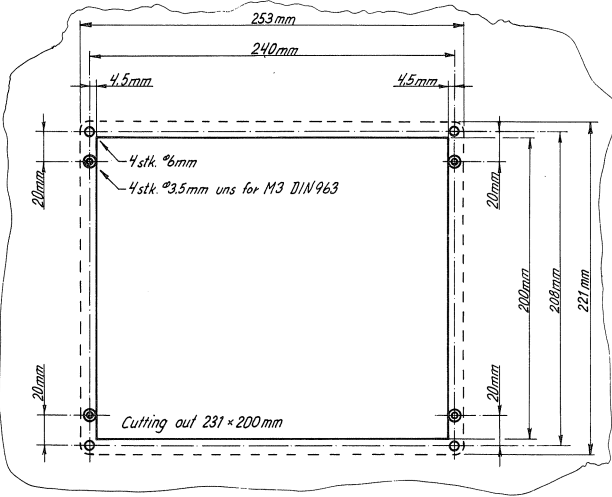
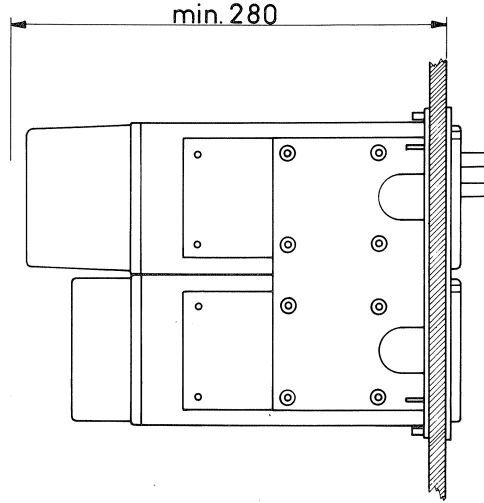
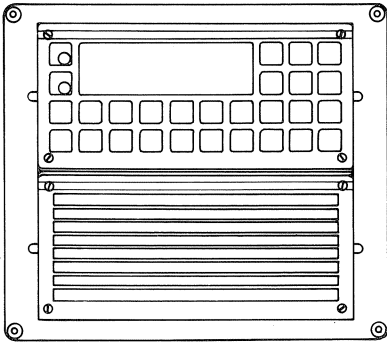

Free distance must be kept to allow free air circulation ambient temperature max. 40°C.

WEIGHT

Mounting kit H2064:	1.5 kg
Loudspeaker H2054:	5.5 kg
Loudspeaker H2074:	4.0 kg
HF SSB RE2100:	4.5 kg

4-0-25937  
4-0-25942

RE2100

4-0-24704

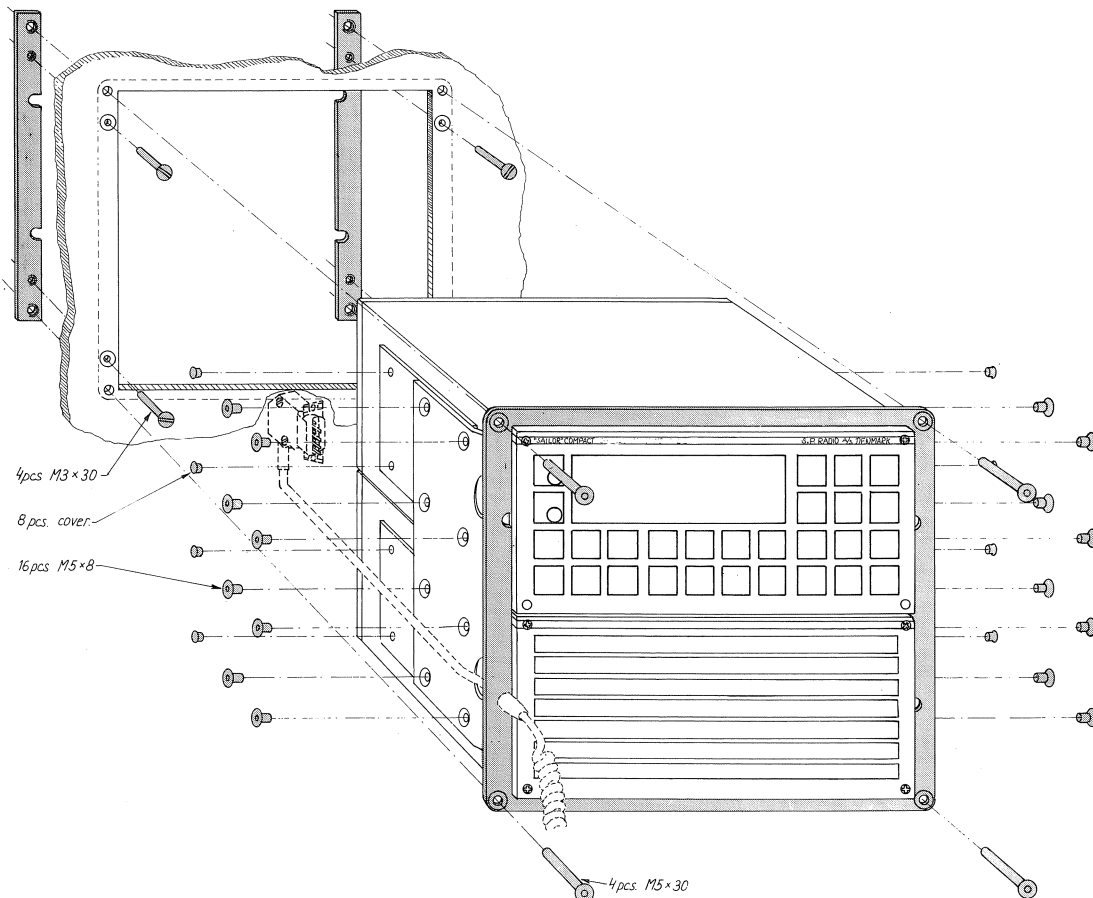

2.2. DIMENSIONS AND DRILLING PLAN cont.:

MOUNTING KIT H2062

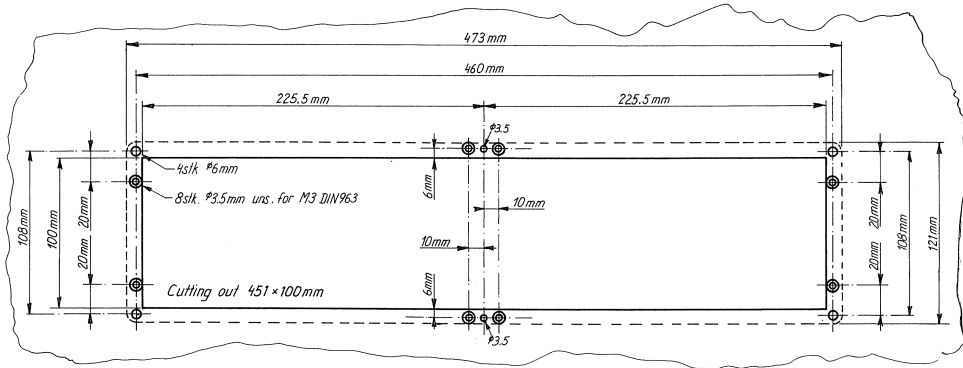
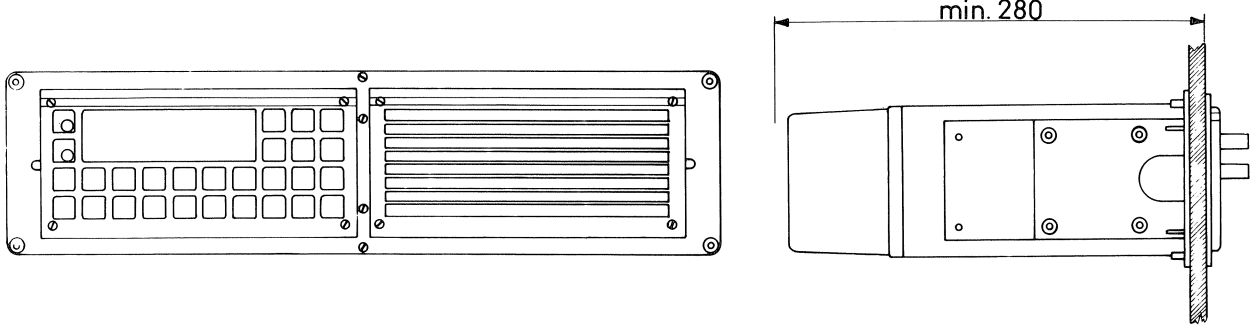

RE2100  
4-0-25943 4-0-24732  
4-0-25944

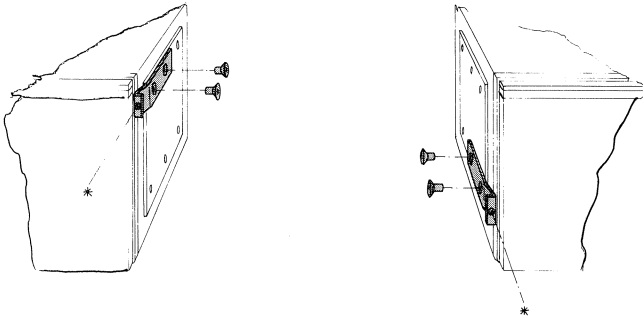

Free distance must be kept to allow free air circulation ambient temperature max. 40°C.

WEIGHT

- Mounting kit H2062: 1.5 kg
- Loudspeaker H2054: 5.5 kg
- Loudspeaker H2074: 4.0 kg
- HF SSB RE2100: 4.5 kg

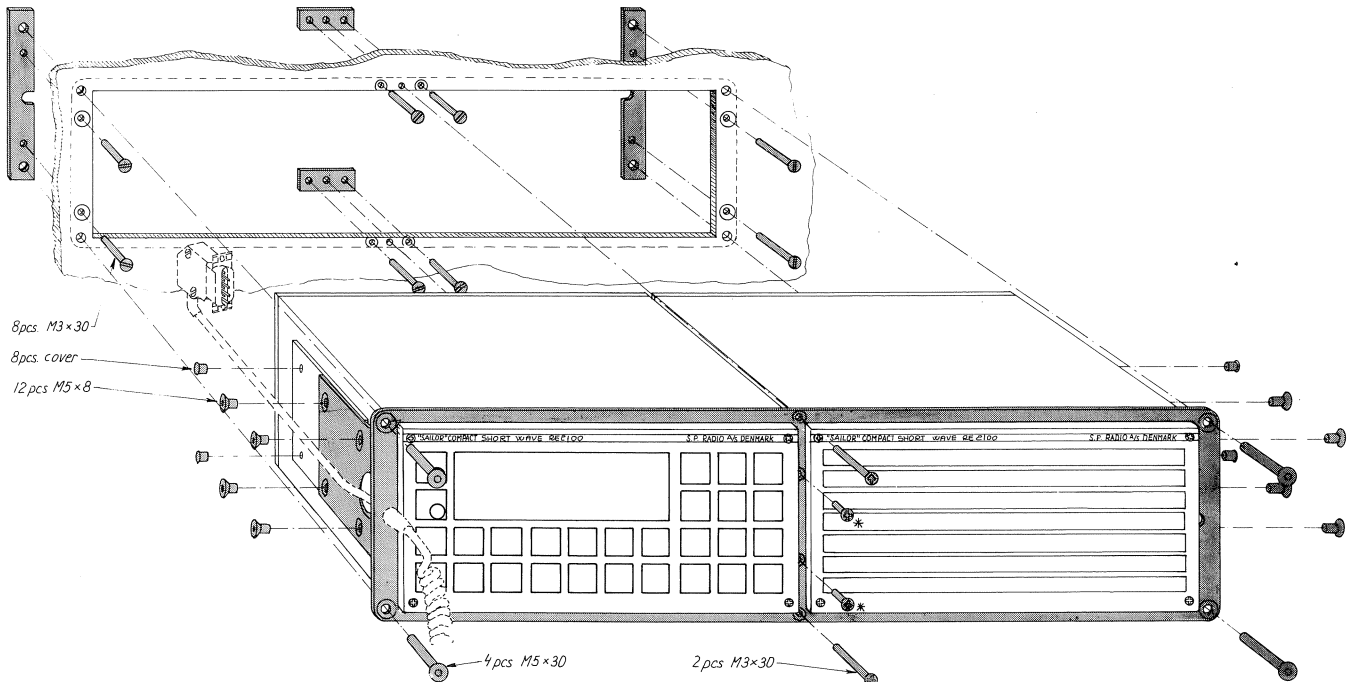





## 2.3. ELECTRICAL CONNECTION AND ASSEMBLING

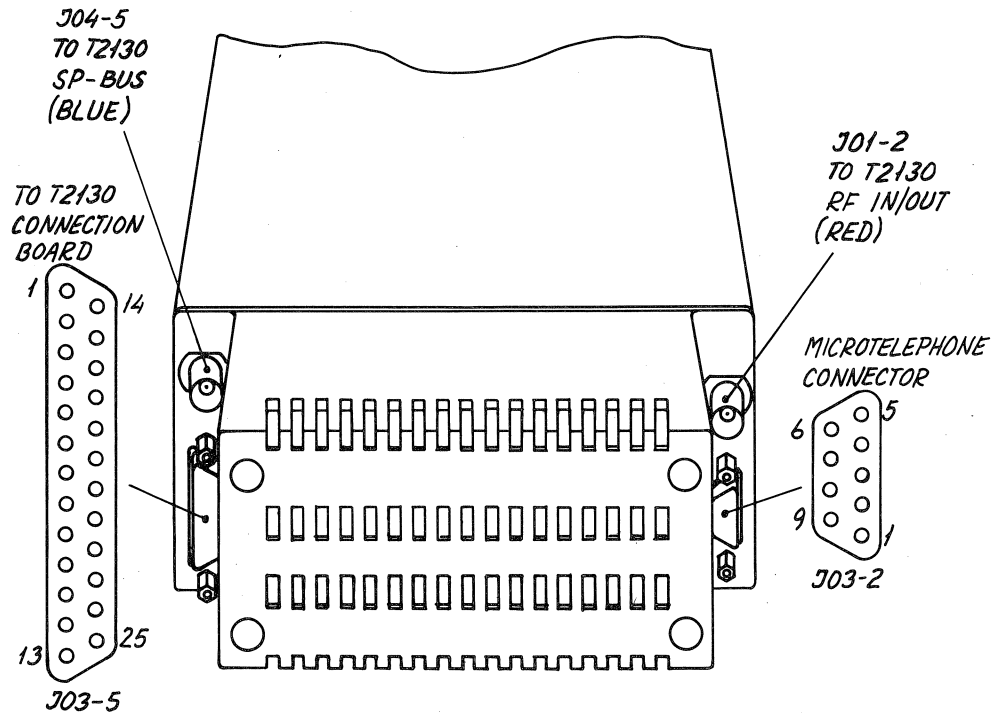

### J03-5

Pin no. 1	Mute RX	black
Pin no. 2	AF to AMP common	brown
Pin no. 3		
Pin no. 4		
Pin no. 5	GND	shield
Pin no. 6	SP BUS interrupt	red
Pin no. 7		orange
Pin no. 8		yellow
Pin no. 9	AUX AF to TX common	green
Pin no. 10	-18V	blue
Pin no. 11	+9V	violet
Pin no. 12	+18V	grey
Pin no. 13	Supply on/off	white
Pin no. 14	Mic key	brown/orange
Pin no. 15	VF/AE-current	brown/yellow
Pin no. 16	AF to AMP	brown/green
Pin no. 17	0 dBm out common	brown/grey
Pin no. 18	0 dBm out	white/orange
Pin no. 19	Ext. RF control	white/yellow
Pin no. 20	AUX AF to TX	white/green
Pin no. 21	RF on/off	white/blue
Pin no. 22	GND	white/grey
Pin no. 23	+9V	violet
Pin no. 24	+18V	grey/orange
Pin no. 25	-battery	red/blue

### J03-2

Pin no. 1	Telephone	red
Pin no. 2	GND	yellow
Pin no. 3	Signal GND	white
Pin no. 4	Mic	blue
Pin no. 5	Mic key	brown
Pin no. 6	Ext. SQ on/off	
Pin no. 7	Distress	
Pin no. 8	Ser.+	
Pin no. 9	+18V	



## CONTENTS

3.	SERVICE
3.1.	MAINTENANCE
3.2.	ALIGNMENT INSTRUCTIONS
3.3.	PROPOSAL FOR NECESSARY TEST EQUIPMENT
3.4.	TROUBLE SHOOTING
3.5.	PERFORMANCE CHECK
3.5.1.	PERFORMANCE CHECK OF DISPLAY AND KEYBOARD
3.5.2.	PERFORMANCE CHECK OF RECEIVER
3.5.3.	PERFORMANCE CHECK OF EXCITER
3.6.	MODULE PERFORMANCE CHECK
3.6.1.	MODULE PERFORMANCE CHECK OF RECEIVER UNIT
3.6.2.	MODULE PERFORMANCE CHECK OF FRONT END UNIT
3.6.3.	MODULE PERFORMANCE CHECK OF SYNTHESIZER UNIT
3.6.4.	MODULE PERFORMANCE CHECK OF EXCITER UNIT
3.6.5.	MODULE PERFORMANCE CHECK OF PROCESSOR UNIT
3.6.8.	MODULE PERFORMANCE CHECK OF POWER UNIT
3.7.	ADJUSTMENT PROCEDURE
3.7.1.	ADJUSTMENT PROCEDURE FOR FRONT END AND RECEIVER UNIT
3.7.2.	ADJUSTMENT PROCEDURE FOR SYNTHESIZER UNIT
3.7.3.	ADJUSTMENT PROCEDURE FOR EXCITER UNIT
3.7.4.	ADJUSTMENT PROCEDURE FOR POWER UNIT
3.8.	NECESSARY ADJUSTMENT AND CHECK AFTER REPAIR
3.9.	FUNCTION CHECK
3.10.	SELECTION AND DESCRIPTION OF THE SERVICE PROGRAMMES



## 3. SERVICE

### 3.1. MAINTENANCE

#### **PREVENTIVE MAINTENANCE**

If the HF SSB RE2100 has been installed in a proper way the maintenance can, dependent on the environments and working hours, be reduced to a performance check at the service workshop at intervals, not exceeding 12 months. A complete performance check list is enclosed in this manual, chapter 3.5 PERFORMANCE CHECK.

Inspection of the antenna, cables, and plugs for mechanical defects, salt deposits, corrosion, and any foreign bodies shall be done at regular intervals not exceeding 12 months.

Along with each RE2100 a test sheet is delivered in which all the measurements, made in the test department of the factory, are listed. If the control measurings made in the service workshop should not show the same values as those listed in the test sheet, the set must be adjusted as specified in chapter 3.7. ADJUSTMENT PROCEDURE.

### 3.2. ALIGNMENT INSTRUCTIONS

#### **INTRODUCTION**

The measuring values indicated in chapter 5. CIRCUIT DESCRIPTION AND SCHEMATIC DIAGRAMS are typical values and as indicated it will be necessary to use instruments in absolute conformity with the below list:

### 3.3. PROPOSAL FOR NECESSARY TEST EQUIPMENT

#### OSCILLOSCOPE:

Bandwidth	DC-35 MHz
Sensitivity	2mV/div
Output Impedance	1 Mohm//20 pF
E.g. Philips type	PM3050

#### PASSIVE PROBE:

Attenuator	20 dB
Input Impedance	10 Mohm//15 pF
Compensation Range	10-30 pF
E.g. Philips type	PM8936/091

#### MULTIMETER:

Sensitivity DC (f.s.d.)	100 mV
Input Impedance	10 Mohm
Accuracy DC (f.s.d.)	1.5%
E.g. Philips type	PM2505

#### FREQUENCY COUNTER:

Frequency Range	100 Hz - 120 MHz
Resolution	1 Hz at $f = 100$ MHz
Accuracy	$1 \cdot 10^{-7}$
Sensitivity	100 mV RMS
Input Impedance	1 Mohm/30 pF
E.g. Philips type	PM6669/031

#### HF SIGNAL GENERATOR:

Frequency Range	100 kHz - 100 MHz
Output Voltage:	0dB/uV - 120 dB/uV
Output Impedance	50 ohm
Type of Modulation	AM
Modulation Frequency	External
E.g. Marconi type	2019

#### LF SIGNAL GENERATOR:

Frequency Range	10 Hz - 10 kHz
Output Voltage	20 mV <sub>RMS</sub> - 1V <sub>RMS</sub>
Output Impedance	600 ohm
Output Waveform	sine wave
E.g. Philips type	PM5110

#### LF DISTORTION METER:

Frequency Range	$f = 1000$ Hz
Distortion Range (f.s.d.)	1-10%
Input Impedance	1 Mohm
Accuracy (f.s.d.)	3%
E.g. Philips type	PM6309

3.3. PROPOSAL FOR NECESSARY TEST EQUIPMENT cont.:

DIODE PROBE

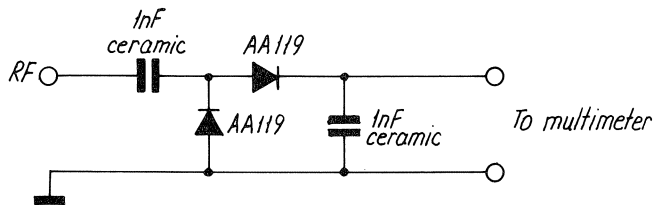

LAYOUT OF THE PROBE

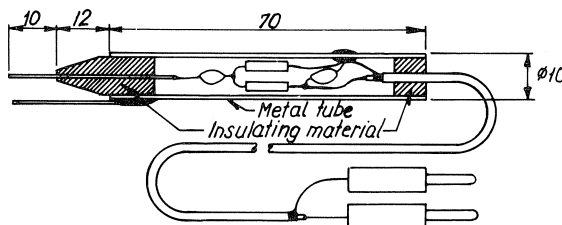

50 OHM DUMMY LOAD

50 ohm -> 50 ohm:

EMF-loss 20 dB

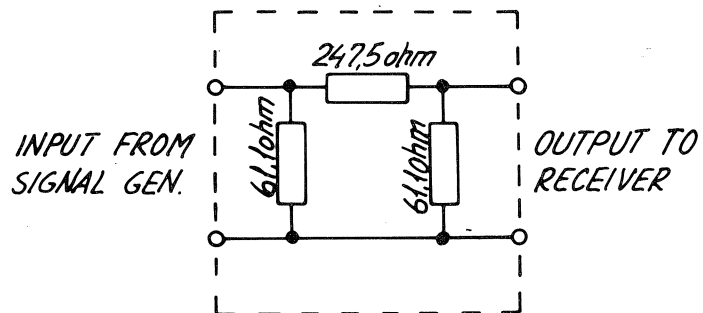

RE2100A / R2122  
4-0-25079

### 3.3. PROPOSAL FOR NECESSARY TEST EQUIPMENT cont.:

#### POWER SUPPLY:

$V_{out1}$	18V DC
$V_{out2}$	18V DC
$I_{out1}$	2 Amp DC
$I_{out2}$	0.5 Amp DC
E.g. 2 pcs. ELCANIC type	3010

#### TESTBOX

To test all the functions of the RE2100 is very difficult when no transmitter T2130 is available. For that reason S. P. Radio has developed and produced a testbox. When using this testbox it is possible in an easy way to test all the inputs and outputs of the RE2100.

The testbox has a built-in AF amplifier, which makes it possible to connect a loudspeaker directly to the testbox.

The testbox has a built-in unit to control the function of the SP-BUS output. By means of the built-in light emitting diodes and switches it is possible to control all the functions of the RE2100.

Specification of measuring instruments, which can be connected to the testbox is given in the beginning of this chapter, and to this list an 8 ohm loudspeaker can be added.

The below diagram shows the electric wiring inside the testbox:

#### COMPONENT LOCATION TESTBOX

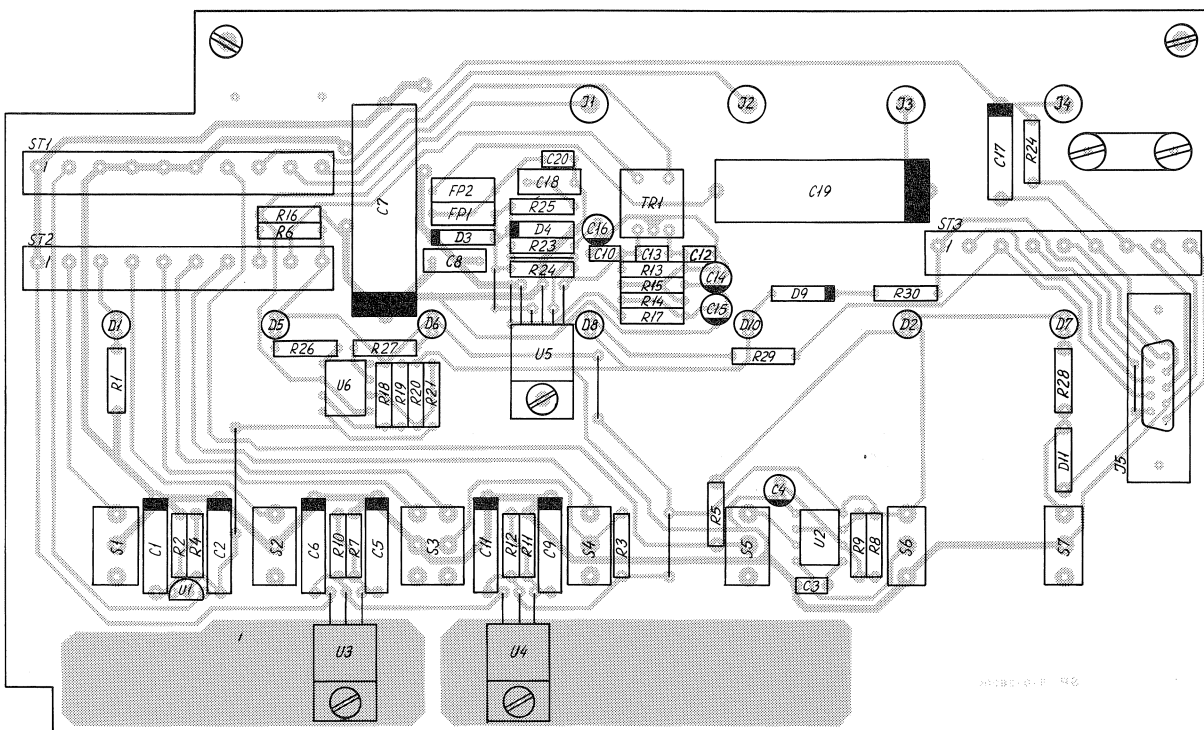



# DIAGRAM TESTBOX

RE2100 4-0-26206A

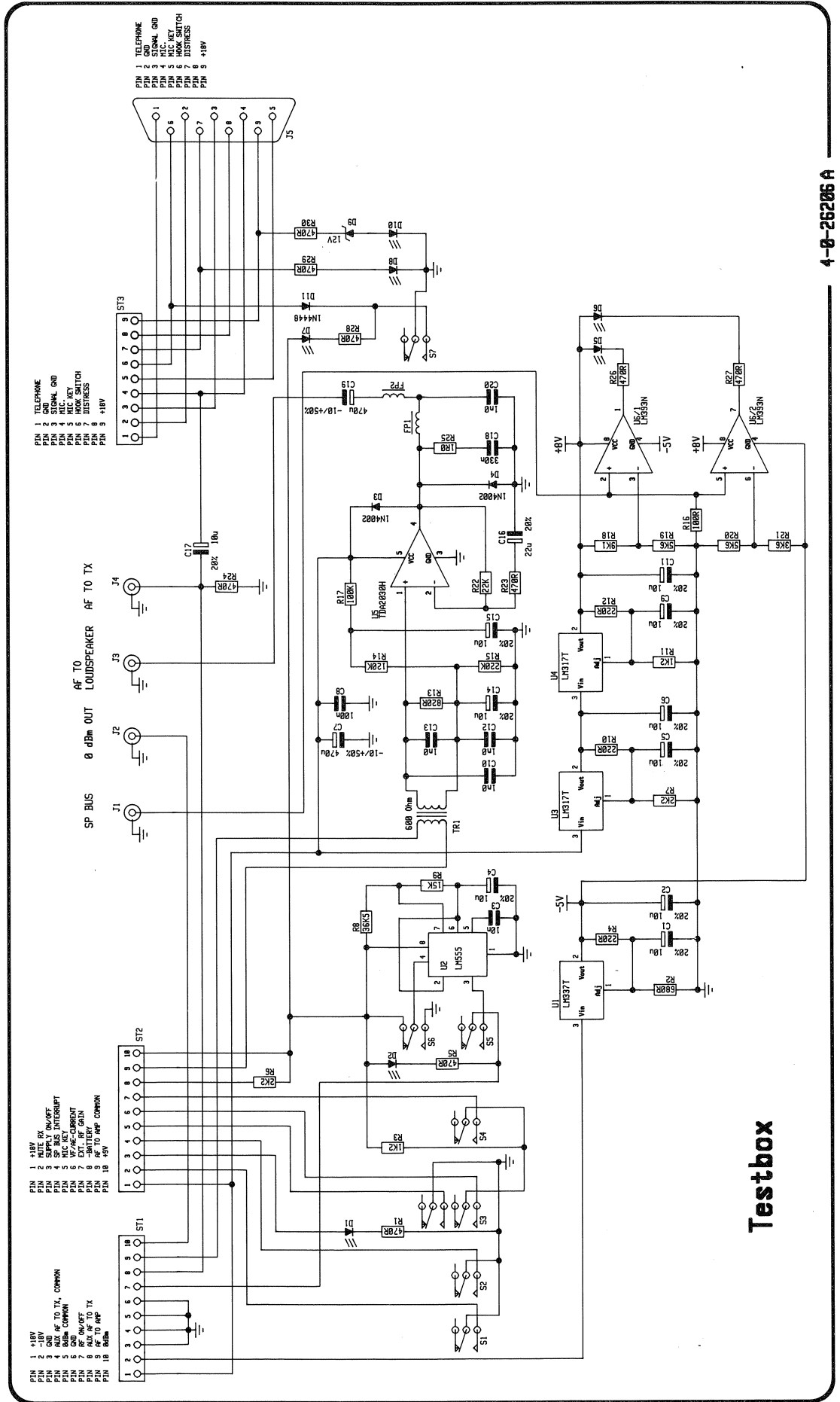

**Testbox**

4-0-26206 A

### 3.3. PROPOSAL FOR NECESSARY TEST EQUIPMENT cont.:

The below diagram shows how to connect the testbox with the RE2100 and the external instruments.

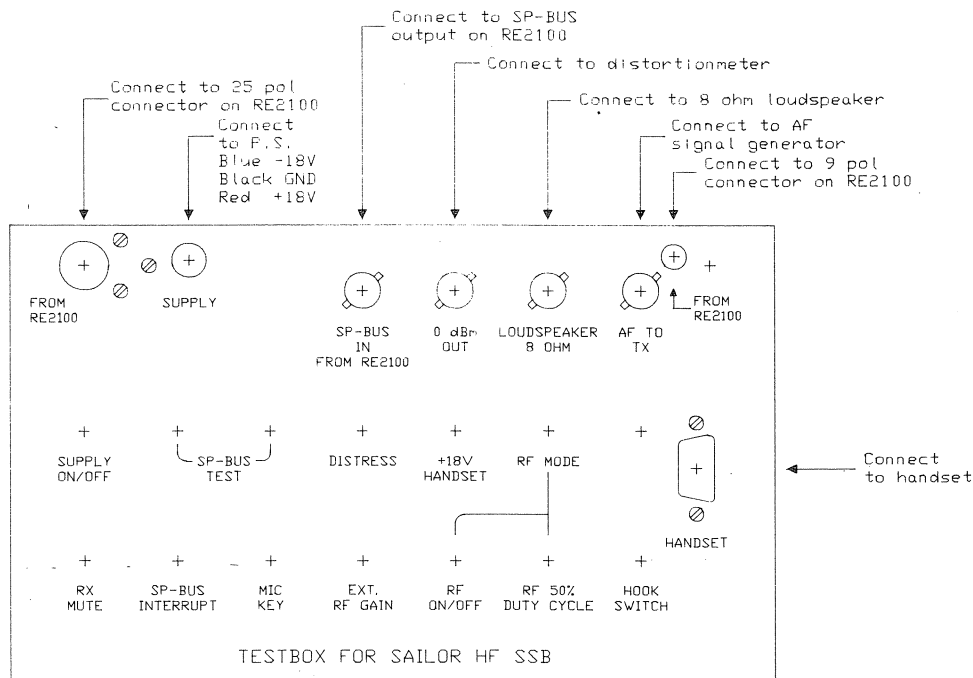

If no testbox is available, it is possible to operate the RE2100 by connecting the power supply directly to the 25-pin connector, which is located at the back of the RE2100. In this 25 pin connector it is possible to find all the other inputs, outputs, and testpoints. The pin configuration for this connector is listed in chapter 2.3. ELECTRICAL CONNECTION AND ASSEMBLING. But it is only necessary to establish the following connections:

- pin No. 10 -18V/0.2 Amp.
- pin No. 11 + 9V/0.5 Amp.
- pin No. 12 +18V/0.8 Amp.
- pin No. 5 GND

The handset is connected directly to the 9-pin connector at the back of the RE2100.

## 3.4. TROUBLE SHOOTING

Trouble shooting should only be performed by persons with sufficient technical knowledge, who have the necessary measuring instruments at their disposal, and who have carefully studied the operation principles and structure of the SAILOR Compact HF SSB System.

SAILOR HF SSB RE2100 has a number of trimming cores and trimmers, which must not be touched, unless adjustments as specified in chapter 3.7. ADJUSTMENT PROCEDURE, can be made.

When measuring the units, short-circuits must be avoided as the transistors would then be spoiled.

### LOCATING THE FAULTY UNIT

When a fault has been observed in the HF SSB system, it can be difficult to find out in which unit the fault can be located.

The first thing to check, is whether the fault is somewhere in the aerial circuit, the handset or in the power source.

If the fault is not found there, check if an error message has been shown in the RX display of the RE2100.

The error codes listed below are error messages, which are generated by the RE2100, and they therefore indicate a fault in this unit.

### ERROR CODES

- 00 Internal power supply is low.  
Check the power connections to the RE2100, or check the internal power regulators.
- 11 Illegal transmitting frequency.  
The TX frequency, of which a tone sequence has been tried, is not legal.
- 12 Illegal transmitting mode.  
The TX emission mode is not legal for transmitting.
- 15 Key sequence is not finished by the <ENT> key.
- 20 The communication link to the transmitter T2130 is interrupted.  
Check the coax cable to the T2130 from RE2100.
- 21 The communication link between RE2100 and control unit C2140 or DSC/telex RM2150/RM2151 has been stopped. Check the SP-BUS coax cable to the external equipment. If the "Error 21" flashes up again after the button <STOP/ENT> has been pressed, then check the SP-BUS interrupt line (J03-5 pin 6). This line has to be normal "High" (approx. +5V).

The error codes listed below are error messages, which are generated by the HF transmitter T2130, and they therefore indicate a possible fault in this unit.

### 3.4. TROUBLE SHOOTING cont.:

These error codes are described more detailed in the instruction manual for T2130, chapter 2.3. SYSTEM DESCRIPTION AND TROUBLE SHOOTING, and in the chapter 3.4. TROUBLE SHOOTING.

#### ERROR CODES

- 70 Motor circuit error AT2110.  
See instruction manual for T2130, chapter 3.4.
- 71 Internal signal error.  
See instruction manual for T2130, chapter 3.4.
- 72 Internal signal error.  
See instruction manual for T2130, chapter 3.4.
- 73 High standing wave ratio (SWR) in the tuning of the AT2110.  
Check the aerial and see instruction manual for T2130, chapter 3.4.
- 74 Transmitter temperature too high.  
Let the transmitter T2130 have a pause and see instruction manual for T2130, chapter 3.4.
- 75 High standing wave ratio (SWR) when transmitting.  
Check the aerial and see instruction manual for T2130, chapter 3.4.
- 76 Battery voltage low.  
Check the condition of the batteries and the power cables. See instruction manual for T2130, chapter 3.4.
- 77 Temperature sensor error.  
See instruction manual for T2130, chapter 3.4.
- 78 Internal high standing wave ratio (SWR).  
See instruction manual for T2130, chapter 3.4.

If the error codes indicate that the fault may be found in the RE2100, the fault is probably no transmitter signal from the RE2100. The exciter can then, without any damage to the transmitter, be set on by activating the test programme SP-05-0.

The error codes do not indicate any receiver fault.

A receiver fault can be in the aerial coupler AT2110, in the transmitter T2130, or in the receiver unit.

To separate a fault in these units, disconnect the aerial cable at the back of RE2100 and connect a wire to the RE2100 coax socket. Try to find a broadcast station and check the receiver. If the fault is still present, it must be located in the RE2100 unit.

### 3.4. TROUBLE SHOOTING cont.:

#### LOCATING THE FAULTY MODULE

If the fault has been located to the RE2100, the exciter can be activated in test programme SP-05-0. The receiver is always activated, when no test programme is activated.

Check the connections to the modules in the RE2100.

The power supply should be the first thing to control, the voltage is indicated in the diagram of each module.

If the power supply is present, control the amplitude of the local oscillator signals.

The next thing to control is whether the other inputs to the module are present. They are indicated in the diagrams of each module with reference to a special set-up of the RE2100.

It should now be possible to locate the faulty module.

#### LOCATING THE FAULTY CIRCUIT

When the faulty module has been found, it can be difficult to find the faulty circuit or component.

One way is to change the module. If this is not possible, the faulty component or circuit can be found in a more systematic way by using the chapter 3.6. MODULE PERFORMANCE CHECK.

Chapter 3.6. MODULE PERFORMANCE CHECK is divided into sections with a headline indicating a possibility of checking some main parameters, and this may be a great help.

## 3.5. PERFORMANCE CHECK

### GENERAL

A performance check is intended to be used as a check after repair and before reinstallation of the equipment.

A performance check can be used to check the equipment after a certain time to make sure that the equipment is according to the required technical specifications.

The performance check is divided into three sections, and it is possible to perform one of the sections or all of them.

Connect the RE2100 with the testbox for the RE2100 and connect the power supply and the handset to the testbox as described in chapter 3.3. PROPOSAL FOR NECESSARY TEST EQUIPMENT.

If no testbox is available, it is possible to operate the RE2100 by connecting the power supply directly to the 25 pin connector, which is located at the back of the RE2100. The pin configuration for this connector is listed in chapter 2.3. ELECTRICAL CONNECTION AND ASSEMBLING. But it is only necessary to establish the following connections:

pin No. 10	-18V/0.2 Amp.
pin No. 11	+ 9V/0.5 Amp.
pin No. 12	+18V/0.8 Amp.
pin No. 5	GND

The handset is connected directly to the 9 pin connector at the back of the RE2100.

This chapter includes a number of measurements where a signal generator is needed. The output level of the generator is, in this manual, expressed in terms of the Electromotive Force (EMF), and it is measured in terms of the unit: dB/uV = 20 log(EMF/1uV), (dB above one microvolt).

The output level from signal generators in general is sometimes expressed in terms of the available power  $P_a$ , which is measured in terms of the unit: dBm = 10 log( $P_a$ /1mW), (dB above one milliwatt). For this reason the conversion formulas between EMF and available power and vice versa are given here:

$$P_a \text{ (dBm)} = \text{EMF (dB/uV)} - 113 \text{ dB}$$

$$\text{EMF (dB/uV)} = P_a \text{ (dBm)} + 113 \text{ dB}$$

where  $P_a$  is the available power and EMF is the Electromotive Force of the generator.

### 3.5.1. PERFORMANCE CHECK OF DISPLAY AND KEYBOARD

Connect the RE2100 with the testbox for RE2100. Connect the power supply +18V/2A, the loudspeaker, and a coax cable from the RE2100 SP-BUS output socket to the proper input terminals on the testbox.

The necessary test equipment to carry out a performance check is described in this manual chapter 3.3. PROPOSAL FOR NECESSARY TEST EQUIPMENT.

#### 3.5.1.1. Performance Check of Display

1. Select test programme SP-00-2.
2. Control that the display is switched between all possible combinations of lighted bars.
3. Control that the mode indicating bars are toggled.
4. Control that the power reduction bars are alight.
5. Press the keyboard ENT key.
6. Select test programme SP-00-3.
7. Control that the two led's marked SP-BUS-TEST on the testbox are alight.
8. Press the keyboard TUNE button.
9. Turn the RF GAIN button fully counter clockwise.
10. Control that the bars in the signal meter are all alight.
11. Turn the RF gain fully clockwise.

#### 3.5.1.2. Performance Check of Keyboard

1. Turn the VOL-OFF button fully counter clockwise and then fully clockwise.
2. Control that the testbox led marked SUPPLY ON/OFF can be switched on and off by the VOL-OFF button.
3. Press the keyboard buttons to key-in the receiver frequency 12345.6 kHz.
4. Press the keyboard button ENT.
5. Control that noise is heard from the loudspeaker.
6. Press the handset button TX.
7. Control that the point in the TX frequency window is toggled.

### 3.5.1. PERFORMANCE CHECK OF DISPLAY AND KEYBOARD cont.:

8. Press the keyboard buttons while the point is toggled to key-in the transmitter frequency 7890.0 kHz.
9. Press the keyboard button ENT.
10. Press the keyboard button CH.
11. The display will now show 'CH-----'.
12. Press the keyboard button SC.
13. The display will now show 'SC X'.
14. Press the keyboard button RX.
15. The display will now show '12345.6 kHz'  
'7890.0 kHz'.
16. Control that the emission mode can be toggled by pressing the keyboard button MODE.
17. Control that the display light can be dimmed by pressing the keyboard button DIM.
18. Control that the led marked AGC can be toggled by pressing the keyboard button AGC.
19. Control that the led marked SQ can be toggled by pressing the keyboard button SQ.
20. Press the keyboard TUNE/CLARIF button.
21. Control that the RX frequency displayed changes to show the 10 Hz decimal '12345.60 kHz'.
22. Press the keyboard FREQ error buttons to toggle the 10 Hz decimal up and down.
23. Press the keyboard TUNE/CLARIF button.
24. Press the keyboard FREQ error buttons to toggle the 100 Hz decimal up and down.
25. Press the keyboard 2182 button.
26. Control that the display shows '2182.0 kHz'  
'2182.0 kHz'
27. Press the keyboard TEST ALARM button.
28. Control that the alarm tones can be heard in the handset earpiece.
29. Press the keyboard button ENT.
30. Press the keyboard buttons SEND ALARM and TEST ALARM.
31. Control that the display shows 'Error 20'  
'2182.0 kHz'  
when these two buttons are pressed simultaneously.



### 3.5.2. PERFORMANCE CHECK OF RECEIVER

Connect the RE2100 with the testbox for RE2100 and connect the power supply and a loudspeaker to the proper inputs on the testbox. The necessary test equipment to carry out a performance check is described in this manual, chapter 3.3. PROPOSAL FOR NECESSARY TEST EQUIPMENT.

This chapter contains the following sections:

- 3.5.2.1. Performance Check of Receiver Sensitivity
- 3.5.2.2. Performance Check of Receiver Distortion
- 3.5.2.3. Performance Check of Receiver Audio Passband
- 3.5.2.4. Performance Check of Receiver Clarifier and Frequency
- 3.5.2.5. Performance Check of Receiver AGC
- 3.5.2.6. Performance Check of Receiver Squelch
- 3.5.2.7. Performance Check of Receiver External Connections

#### 3.5.2.1. Performance Check of Receiver Sensitivity

1. Connect the signal generator to the aerial socket through the 50 ohm dummy load described in this manual, chapter 3.3.
2. Connect a voltmeter or a distortion meter to the 0 dBm output on the testbox.
3. Choose receiver frequency  $f_{RX}$ , generator frequency  $f_G$ , and generator output level  $V_G$  according to table in point 5.
4. Measure the signal to noise ratio  $SND/N$  with the distortion meter or the voltmeter as described in point 6. The measured signal to noise ratio shall be better than 20 dB.

5.

Signal Generator			RE2100		
$f_G$ (MHz)	$V_G$ (EMF)	MODE	$f_{RX}$ (MHz)	MODE	
0.100	30 dB/uV	AM 30% with 1kHz	0.100	H3E	
0.384			0.384		
0.385			0.385		
1.599			1.599		
1.601	11 dB/uV	CW	1.600	J3E	
2.101			2.100		
2.182	25 dB/uV	AM 30% with 1 kHz	2.182	H3E	FIXED
4.500	11 dB/uV	CW	4.499	J3E	
4.501			4.500		
9.000			8.999		
9.001			9.000		
13.251			13.250		
18.000			17.999		
18.101			18.100		
25.001			25.000		
29.998	11 dB/uV	CW	29.999	J3E/LSB	

### 3.5.2. PERFORMANCE CHECK OF RECEIVER cont.:

6. Measurement of the signal to noise SND/N.  
With the specified test signal applied to the receiver, the measurement of SND/N is performed as described below.

#### SSB MODE

- a. Turn the RF-GAIN control fully clockwise and make sure that the AGC is operative.
- b. Notice the output LF level by means of a voltmeter.
- c. Turn the AGC OFF and adjust the RF-GAIN control to achieve the output level found in point 6.b.
- d. Change the signal generator frequency  $f_G$  to  $f_{RX} + 30$  kHz and notice the reduction of the LF output level, which expresses the signal to noise ratio.

#### AM MODE

- e. Turn the RF-GAIN fully clockwise and make sure that the AGC is operative.
- f. Notice the output level by means of a voltmeter.
- g. Remove modulation from the generator signal and notice the reduction of the output, which expresses the signal to noise ratio.

#### 3.5.2.2. Performance Check of Receiver Distortion

To carry out the check as described below, it is necessary to have a distortion meter at your disposal. If this is not possible, the check can be done by an oscilloscope, but please note that it should not be possible to see a distortion of 10% or less on the oscilloscope.

1. Connect a distortion meter to the 0 dBm output on the testbox.
2. Connect a signal generator to the aerial socket through a 50 ohm dummy load.
3. Choose receiver frequency  $f_{RX}$  generator frequency  $f_G$  and generator output level  $V_G$  according to point 5.
4. Measure the signal distortion SND/ND with the distortion meter. The measured distortion SND/ND shall be better than the figures given in the table in point 5.

5.

Signal Generator			RE2100		
$f_G$ (kHz)	$V_G$ (EMF)	MODE	$f_{RX}$ (kHz)	MODE	Distortion SND/ND
2182	83 dB/uV	AM 30% with 1 kHz	2182	H3E	2.0%
2183	83 dB/uV	CW	2182	J3E	1.5%

### 3.5.2. PERFORMANCE CHECK OF RECEIVER cont.:

#### 3.5.2.3. Performance Check of Receiver Audio Passband

1. Connect the signal generator to the aerial socket through a 50 ohm dummy load.
2. Connect a voltmeter to the 0 dBm output on the testbox.
3. Choose receiver frequency  $f_{RX}$ , generator frequency  $f_G$ , generator output level  $V_G$  according to point 7.
4. **USB-SSB MODE**
  - a. Set the  $f_{RX}$ ,  $f_G$  and  $V_G$  according to point 1 in the table in point 7.
  - b. Turn the RF-GAIN control fully clockwise and make sure that the AGC is operative.
  - c. Notice the AF output level by means of the voltmeter.
  - d. Turn the AGC off and adjust the RF-GAIN control to achieve the output level found in point 4.c.
  - e. Change the signal generator frequency  $f_G$ , and the generator output level  $V_G$  according to point 2 in table 7, and control the voltage on 0 dBm output to be above the value found in point 4.c.
  - f. Change  $f_G$  according to point 3 in table 7 and control the voltage on 0 dBm output to be below the value found in point 4.c.
5. **LSB-SSB MODE**

Carry out point 4. USB-SSB MODE, but use the figures mentioned in point 7, under "lower sideband audio passband".
6. **AM MODE**
  - a. Set  $f_{RX}$ ,  $f_G$  and  $V_G$  according to point 4 in table 7.
  - b. Notice the AF output level by means of the voltmeter.
  - c. Change the modulation frequency according to the figures in point 5 in table 7, and control that the voltage on 0 dBm output has not dropped 6 dB below the value found in point 6.b.
  - d. Change the modulation frequency according to the figures in point 6 in table 7, and control that the voltage on 0 dBm output has dropped more than 20 dB below the value found in point 6.b.

### 3.5.2. PERFORMANCE CHECK OF RECEIVER cont.:

7.

Signal Generator			RE2100		
$f_G$ (kHz)	$V_G$ (EMF)	MODE	$f_{RX}$ (kHz)	MODE	Point
Upper sideband audio passband					
4126	53 dB/uV	CW	4125	J3E	1
4125.35	59 dB/uV				2
4127.7					3
4128.1	73dB/uV				3
Lower sideband audio passband					
4124	53dB/uV	CW	4125	LSB/J3E	1
4124.65	59dB/uV				2
4122.3					3
4121.9	73dB/uV				3
Audio passband by amplitude modulation					
4125	63dB/uV	AM 30% with 1 kHz	4125	H3E	4
		AM 30% with 100 Hz			5
		AM 30% with 3000 Hz			6
		AM 30% with 6000 Hz			

RE2100A

#### 3.5.2.4. Performance Check of Receiver Clarifier and Frequency

1. Connect the signal generator to the aerial socket through a 50 ohm dummy load.
2. Choose receiver frequency  $f_{RX}$ , signal generator frequency  $f_G$ , and the generator output level  $V_G$  according to point 6.
3. Connect a frequency counter to 0 dBm output on the testbox.
4. Activate the frequency tune and let the frequency  $f_{RX}$  change in 100 Hz steps and control with the counter that this happens.
5. Activate the clarifier tune and let the frequency  $f_{RX}$  change in 10 Hz steps and control with the counter that this happens.

### 3.5.2. PERFORMANCE CHECK OF RECEIVER cont.:

6.

Signal Generator			RE2100	
$f_G$ (kHz)	$V_G$ (EMF)	MODE	$f_{RX}$ (kHz)	MODE
25001.0	73dB/uV	CW	25000.1	J3E

7. With the frequency and clarifier tune, set the frequency  $f_{RX}$  to 25000.07 kHz.
8. Control with the counter the output frequency to be 930 Hz  $\pm$ 10 Hz.

**NOTE!** The frequency tolerance of the signal generator shall be better than  $\pm 2.5$  Hz 0.1 ppm. If not and if the counter has a frequency tolerance of 0.1 ppm, carry out the measurement in section 3.5.3.2. Performance Check of Exciter Frequency.

#### 3.5.2.5. Performance Check of Receiver AGC

1. Connect the signal generator to the aerial socket through a 50 ohm dummy load.
2. Connect a voltmeter to the 0 dBm output on the testbox.
3. Choose receiver frequency  $f_{RX}$ , generator frequency  $f_G$ , and generator output level  $V_G$  according to the table in point 4.

4.

Signal Generator			RE2100	
$f_G$ (kHz)	$V_G$ (EMF)	MODE	$f_{RX}$ (kHz)	MODE
1991	8dB/uV	CW	1990	J3E

5. Turn the RF-GAIN control fully clockwise, and make sure that the AGC is operative.
6. Notice the AF output level by means of the voltmeter at the 0 dBm output.
7. Increase the output level of the signal generator to 28 dB/uV.
8. The increase in AF output level measured with the voltmeter shall be less than 3 dB.
9. Notice the AF output level by means of the voltmeter at the 0 dBm output.
10. Turn the AGC OFF and adjust the RF-GAIN control to achieve the output level found in point 9.
11. Disconnect the signal generator from the aerial socket and notice the reduction of the AF output level, which shall be at least 35 dB.
12. Reconnect the signal generator to the aerial socket.

### 3.5.2. PERFORMANCE CHECK OF RECEIVER cont.:

13. Turn the RF-GAIN control fully clockwise and make sure that the AGC is operative.
14. Notice the AF output level by means of the voltmeter at the 0 dBm output.
15. Increase the output level of the signal generator to 78 dB/uV.
16. The increase in AF output level measured with the voltmeter shall be less than 2 dB.
17. Connect 0 dBm output from the testbox to channel A on the oscilloscope.
18. Connect the SP-BUS output socket on RE2100 to channel B on the oscilloscope.
19. Select test programme SP-04-6.
20. Set the timebase on the oscilloscope to 20 msec/div.
21. Set the oscilloscope to trig on channel B.
22. Control that the oscilloscope displays the response shown in figure SSB attack.

#### SSB ATTACK

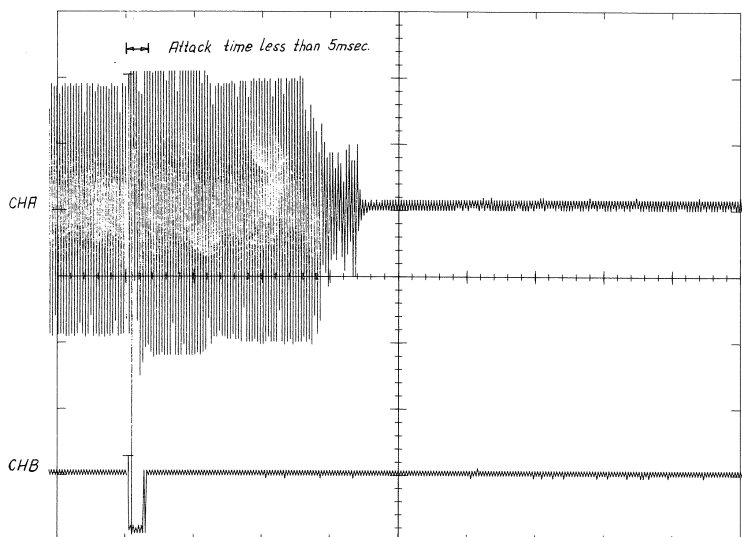

A = 0.5V/div  
B = 5V /div.

20 msec/div

23. Set the timebase on the oscilloscope to 200 msec/div.
24. Control that the oscilloscope displays the response shown in figure SSB decay.

### 3.5.2. PERFORMANCE CHECK OF RECEIVER cont.:

#### SSB DECAy

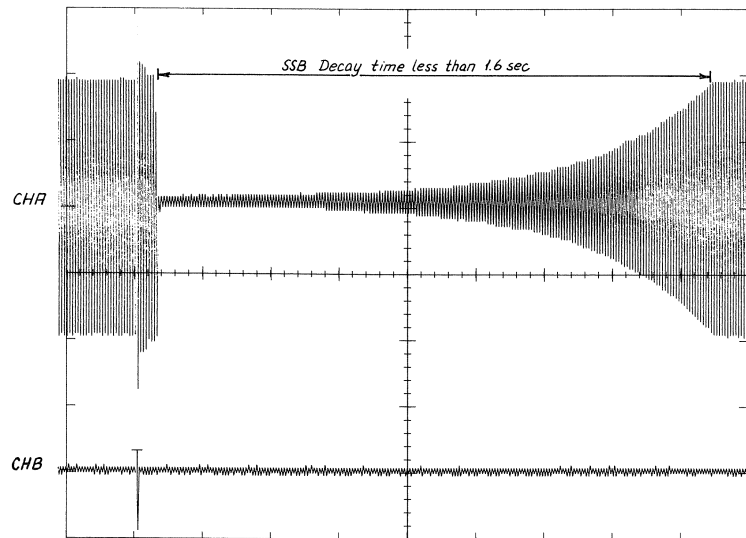

A = 0.5V/div.  
B = 5V /div.

200 msec/div.

25. Select test programme SP-04-7.
26. Set the timebase on the oscilloscope to 50 msec/div.
27. Set the signal generator in amplitude modulation mode, modulating LF signal 1.0 kHz and modulating index  $M = 0.3$ .
28. Control that the oscilloscope displays the response shown in figure AM attack and decay.

#### AM ATTACK AND DECAy

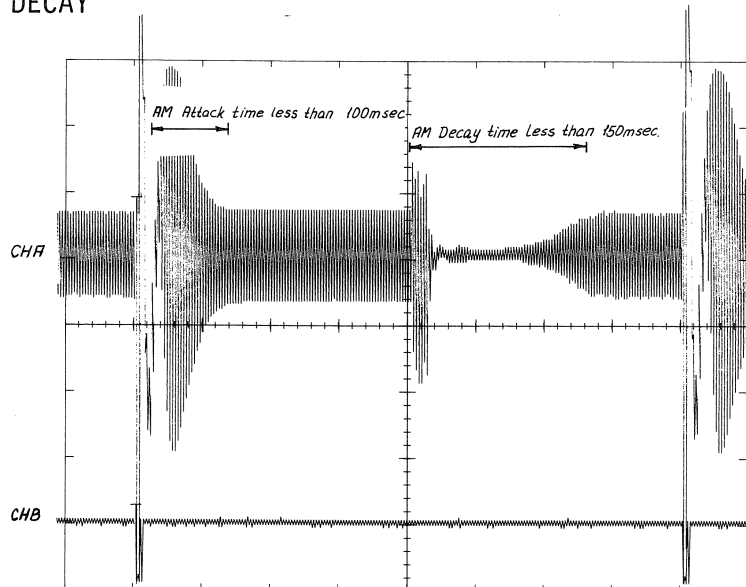

A = 1.0V/div.  
B = 5.0V/div.

50 msec/div.

### 3.5.2. PERFORMANCE CHECK OF RECEIVER cont.:

#### 3.5.2.6. Performance Check of Receiver Squelch

1. Connect a signal generator to the aerial socket through a 50 ohm dummy load.
2. Choose the receiver frequency  $f_{RX}$ , signal generator frequency  $f_G$ , and the generator output level  $V_G$  according to table in point 8.
3. Make sure that the AGC and SQUELCH are active and adjust the AF volumen until a tone is heard in the loudspeaker.
4. Disconnect the signal generator from the aerial socket on the RE2100. You will now hear the receiver noise from the loudspeaker.
5. Control that the AF output is muted after about 10 secs.
6. Connect the signal generator to the aerial socket again.
7. Control that the squelch opens instantly and that you now hear a 1 kHz tone from the loudspeaker.
8. Control that the squelch closes after about 10 secs.

9.

Signal Generator			RE2100	
$f_G$ (kHz)	$V_G$ (EMF)	MODE	$f_{RX}$ (kHz)	MODE
1991	13dB/uV	CW	1990	J3E

#### 3.5.2.7. Performance Check of Receiver External Connections

1. If no testbox for RE2100 is available, the connections can be found and checked in the 25 pin connector and the 9 pin connector at the back of the RE2100.
2. Press the front panel key <2182> fixed.
3. Control that the light emitting diodes names distress and +18 handset at the testbox are alight.
4. Connect a signal generator to the aerial socket through a 50 ohm dummy load.
5. Choose receiver frequency  $f_{RX}$ , signal generator frequency  $f_G$  and the generator output  $V_G$  according to table in point 6.

6.

Signal Generator			RE2100	
$f_G$ (kHz)	$V_G$ (EMF)	MODE	$f_{RX}$ (kHz)	MODE
2183	50dB/uV	CW	2182	J3E

7. A 1 kHz tone shall be heard from the loudspeaker and approx. seven bars in the signal strength meter are alight.



3.5.2. PERFORMANCE CHECK OF RECEIVER cont.:

8. Activate the RX mute switch on the testbox.
9. No tone or noise shall now be heard from the loudspeaker and approx. 2 bars in the signal strength meter are alight.
10. Release the RX mute switch.
11. Activate the TEST ALARM button on RE2100 and control that the alarm tones can be heard in the handset earpiece.

### 3.5.3. PERFORMANCE CHECK OF EXCITER

Connect the RE2100 with the testbox for RE2100.

Connect a  $\pm 18\text{V}/2\text{A}$  power supply, an LF signal generator, and the handset to the proper inputs on the testbox.

The necessary test equipment for executing the performance check is described in this manual, chapter 3.3. PROPOSAL FOR NECESSARY TEST EQUIPMENT.

This chapter consists of the following sections:

- 3.5.3.1. Performance Check of Exciter Output Signal
- 3.5.3.2. Performance Check of Exciter Frequencies and Classes of Emission
- 3.5.3.3. Performance Check of Exciter Microphone Amplifier and LF Response
- 3.5.3.4. Performance Check of Exciter Step Attenuator

#### 3.5.3.1. Performance Check of Exciter Output Signal

1. Connect a 50 ohm resistor to the aerial socket. Two 100 ohm resistors in parallel soldered on a coax cable connected to the aerial socket are sufficient.
2. Connect an oscilloscope through a 10:1 probe to the 50 ohm resistor.
3. Connect the LF signal generator to the AF TO TX input on the testbox.
4. Select test programme SP-05-1 ( $f_{TX} = 22.000 \text{ kHz}$ ).
5. Set the testbox switch RF ON/OFF on.
6. Adjust the LF signal generator to an output of 1Vpp ( $0.350\text{V}_{\text{RMS}}$ ) and a frequency of 1600 Hz.
7. Control that the HF output shown on the oscilloscope is  $3.50 \pm 0.50\text{Vpp}$ .
8. Readjust the oscilloscope gain until full deflection (8 div.) is seen on the screen.
9. Select test programme SP-05-5 ( $f_{TX} = 14.900 \text{ kHz}$ ).
10. Control that deflection now seen is approx.  $8.0 \pm 1.0 \text{ div.}$
11. Select test programme SP-05-4 ( $f_{TX} = 28.000 \text{ kHz}$ ).
12. Control that deflection now seen is approx.  $8.0 \pm 1.0 \text{ div.}$
13. Select test programme SP-05-6 ( $f_{TX} = 1.600 \text{ kHz}$ ).
14. Control that deflection now seen is approx.  $8.0 \pm 1.0 \text{ div.}$
15. Set the testbox switch RX ON/OFF off.
16. Select test programme SP-05-0 ( $f_{TX} = 22.000 \text{ kHz}$ ).

### 3.5.3. PERFORMANCE CHECK OF EXCITER cont.:

17. Set the testbox switch MIC.KEY on.
18. Control that the HF output shown on the oscilloscope is  $4.0 \pm 0.5V_{pp}$  and that it is a two tone signal which is displayed.
19. Control that approx. 7 bars in the signal strength meter are alight.
20. Set the testbox switch MIC.KEY off.
21. Activate the handset key and control that the two tone signal is displayed on the oscilloscope screen.
22. Activate the keyboard button TUNE.
23. Activate the keyboard button TEST ALARM.
24. Control that the alarm tone can be heard in the handset earpiece.

#### 3.5.3.2. Performance Check of Exciter Frequencies and Classes of Emission

1. If only this section is performed, please start by carrying out the section 3.5.3.1. point 1, 2, and 3.
2. Select test programme SP-05-6 ( $f_{TX} = 1.600 \text{ kHz}$ ).
3. Set the testbox switch RF ON/OFF on.
4. Adjust the LF signal generator to an output of  $1V_{pp}$  ( $0.35V_{RMS}$ ) and a frequency of 1600 Hz.
5. Adjust the oscilloscope gain until full deflection (8 div.) is seen on the screen.
6. Toggle the MODE switch on RE2100 between J3E, R3E, H3E, and TELEX, and control that the deflection is approx. the same in all the classes of emission  $8.0 \pm 1.0 \text{ div.}$
7. Disconnect the LF signal generator.
8. Select the emission mode H3E on RE2100 and control that the deflection seen on the oscilloscope is  $4.6 \pm 0.5 \text{ div.}$
9. Select the emission mode R3E on RE2100 and control that the deflection seen on the oscilloscope is  $1.2 \pm 0.2 \text{ div.}$
10. Select test programme SP-05-4 ( $f_{TX} = 28.000 \text{ MHz}$ ).
11. Select the emission mode H3E on RE2100.
12. Connect a frequency counter through a 10:1 probe to the 50 ohm resistor at the HF output socket.
13. Control that the frequency is  $28,000,000 \pm 10 \text{ Hz}$ .  
**NOTE!** The frequency tolerance of the counter shall be better than 0.1 ppm.
14. Set the testbox switch RF 50% DUTY CYCLE on.

### 3.5.3. PERFORMANCE CHECK OF EXCITER cont.:

15. Connect the oscilloscope through a 10:1 probe to the 50 ohm resistor at the HF output socket, and disconnect the frequency counter.
16. The HF signal seen on the oscilloscope screen is switched on for 250 msec and then off for 250 msec.
17. Control that the attack time of the HF signal is not more than 2 msec, and that the decay time is not more than 3 msec.
18. Set the testbox switch RF 50% DUTY CYCLE off and the testbox switch RF ON/OFF off.

If TELEX MODE is possible carry out the following points, if not go to the next section 3.5.3.3.

19. Connect the LF signal generator to the AF TO TX input on the testbox.
20. Adjust the LF signal generator output to 3Vpp/1600 Hz.
21. Select the emission mode TELEX on RE2100.
22. Set the testbox switch MIC.KEY on.
23. Control that the HF output shown on the oscilloscope is  $4.0 \pm 0.5V_{pp}$ .

#### 3.5.3.3. Performance Check of Exciter Microphone Amplifier and LF Response

1. If only this chapter is performed, please start by carrying out the section 3.5.3.1. point 1, 2, and 3.
2. Select test programme SP-05-6 ( $f_{TX} = 1.600$  kHz).
3. Set the testbox MIC-KEY on.
4. Set the LF signal generator frequency to 1Vpp/1600 Hz.
5. Adjust the LF signal generator frequency until the deflection seen on the oscilloscope is max. approx. 1600 Hz.
6. Adjust the oscilloscope gain until full deflection (8 div.) is seen on the screen.
7. Adjust the LF signal generator frequency to 350 Hz and to 2700 Hz and control that the deflection seen on the oscilloscope screen is above 4.0 div.
8. Set the LF signal generator frequency to 1.0Vpp/1000 Hz.
9. Adjust the oscilloscope gain until full deflection (8 div.) is seen on the screen.
10. Adjust the LF signal generator output level until the HF output level seen on the oscilloscope is approx. 7.5 div.
11. Control that the LF signal generator level at the input of the testbox is now  $100 \pm 50$  mVpp.

### 3.5.3. PERFORMANCE CHECK OF EXCITER cont.:

#### 3.5.3.4. Performance Check of Exciter Step Attenuator

1. If only this chapter is performed, please start by carrying out the section 3.5.3.1. point 1 and 2.
2. Select test programme SP-05-2.
3. Check that the stairs and staircase waveform seen on the oscilloscope screen has a continuous decreasing amplitude as shown below.

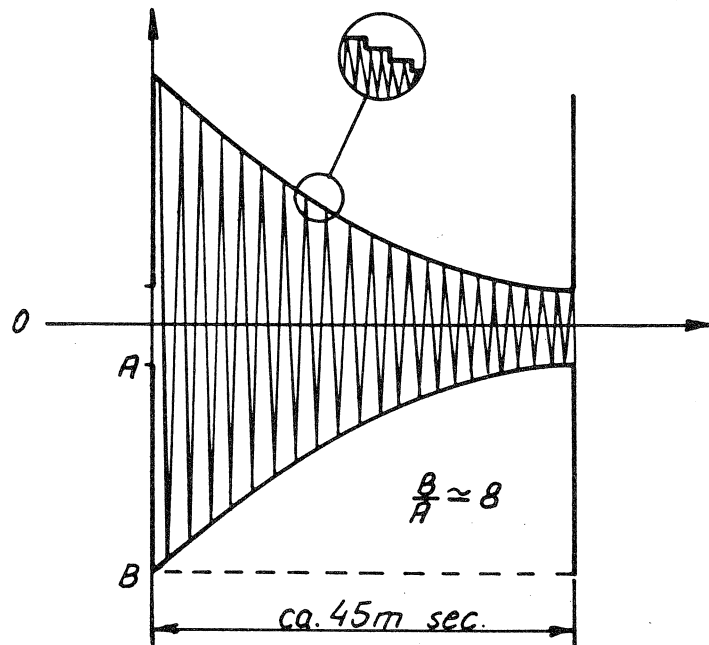



## 3.6. MODULE PERFORMANCE CHECK

### GENERAL

A module performance check is intended to be used as an integral part of the trouble-shooting, because it gives the technician a chance to control the individual modules and parts of the circuit on each module.

The module performance check is divided into subsections, which correspond to the individual modules, and each of these subsections contains a number of check procedures.

The module performance check is carried out with all modules mounted in the HF SSB RE2100, and if a testbox is available, it should be used. The RE2100, the power supply, and the handset are all connected to the testbox as described in chapter 3.3. PROPOSAL FOR NECESSARY TEST EQUIPMENT.

If no testbox is available, it is possible to operate the RE2100 by connecting the power supply directly to the 25 pin connector, which is located at the back of the RE2100. The pin configuration for this connector is listed in chapter 2.3. ELECTRICAL CONNECTION AND ASSEMBLING. But it is only necessary to establish the following connections:

pin No. 10	-18V/0.2A
pin No. 11	+ 9V/0.5A
pin No. 12	+18V/0.8A
pin No. 5	GND

The handset is connected directly to the 9 pin connector at the back of the RE2100.

This chapter includes a number of measurements where a signal generator is needed. The output level of the generator is, in this manual, expressed in terms of the Electromotive Force (EMF), and it is measured in terms of the unit: dB/uV = 20 log(EMF/1uV), (dB above one microvolt).

The output level from signal generators in general is sometimes expressed in terms of the available power  $P_a$ , which is measured in terms of the unit: dBm = 10 log( $P_a$ /1mW), (dB above one milliwatt). For this reason the conversion formulas between EMF and available power and vice versa are given here:

$$P_a \text{ (dBm)} = \text{EMF (dB/uV)} - 113 \text{ dB}$$

$$\text{EMF (dB/uV)} = P_a \text{ (dBm)} + 113 \text{ dB}$$

where  $P_a$  is the available power and EMF is the Electromotive Force of the generator.

## 3.6.1. MODULE PERFORMANCE CHECK OF RECEIVER UNIT

This chapter contains the following sections:

- 3.6.1.1. Check of Sensitivity (RX-Module)
- 3.6.1.2. Check of LO2 and Reinjection Signals
- 3.6.1.3. Check of Crystal Filters (2nd IF)
- 3.6.1.4. Check of 2nd IF Amplifier
- 3.6.1.5. Check of AGC Circuit
- 3.6.1.6. Check of Detector
- 3.6.1.7. Check of AF Filters
- 3.6.1.8. Check of Earpiece Amplifier
- 3.6.1.9. Check of Squelch Circuit

### 3.6.1.1. Check of Sensitivity (RX Module)

The sensitivity of the receiver unit is mainly determined by the Second Mixer because of its relatively large power gain of about 8 dB. It is therefore most likely that a degradation of the sensitivity is caused by the mixer; but be aware that this is not the only possible failure.

A degradation of the sensitivity could also be caused by a failure in the IF-amplifier, detector, audio frequency circuit, or simply by a missing local oscillator signal (LO2 or carrier reinjection).

To obtain a correct measurement of sensitivity, it is necessary to feed the generator signal through an impedance matching network as shown below.

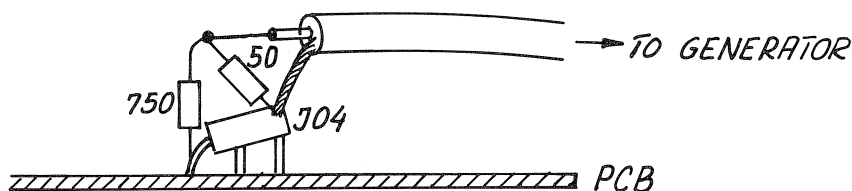

Impedance matching between generator and receiver module.

1. Connect the generator to receiver module through the impedance matching network shown above.
2. Connect the voltmeter to earpiece output at testpoint TR2-1 for measuring the AC-voltage.
3. Turn the RE2100 on.
4. Choose generator frequency  $f_G$  and generator output level  $V_G$  as specified in point 6. Select the wanted Receiver Mode (SSB/AM).
5. Measure the signal to noise ratio  $SND/N$  at the earpiece output and check that it is above 20 dB. (see section 3.5.2.1., point 6 for instructions about how to measure  $SND/N$ ).



### 3.6.1. MODULE PERFORMANCE CHECK OF RECEIVER UNIT cont.:

6.	Signal Generator			RE2100	
	$f_G$	$V_G$ (EMF)	Mode	$f_{RX}$	Mode
	69.999.640 Hz	20 dB/uV	CW	no specification	J3E (SSB)
	70.000.640 Hz	35 dB/uV	AM mod. 30% with 1 kHz	no specification	H3E (AM)

#### 3.6.1.2. Check of L02 and Reinjection Signals

The L02 signal is used in the mixing process from the 1st IF at 70.00064 MHz to the 2nd IF at 10.73152 MHz. The frequency of the L02 signal is 59.26912 MHz when receiving a H3E signal or J3E-USB signal. In J3E-LSB mode the frequency of the L02 signal is 80.73216 MHz.

The carrier reinjection signal is used in the detection of signals with a reduced carrier or signals without any carrier. The frequency of the carrier reinjection signal is 10.73152 MHz and is given by the TCX0.

1. Turn the RE2100 on and select J3E-USB mode.
2. To check the L02 signal, connect the diode probe across the resistor R188-1, which is located at the output of the L0 buffer at the Receiver Unit (module 1).
3. Check the measured DC voltage to be 3.3V  $\pm$ 0.5V.
4. To check the reinjection signal connect a DC voltmeter through the diode probe to pin 8 at the detector IC (LM3189).
5. Check the measured DC voltage to be 300 mV  $\pm$ 50 mV.

#### 3.6.1.3. Check of Crystal Filters (2nd IF)

The selectivity of the second intermediate frequency is given by the crystal filters (SSB or AM filter), which form an important part of the overall receiver selectivity.

If the 2nd IF selectivity cannot fulfil the specified requirements, it is probably caused by a mistuning of the two crystal filters or by a mistuning of the 1st IF filter at 70 MHz.

The crystal filters are tuned by the trimming capacitor C18-1, which is located at the receiver unit. The adjustment procedure for this capacitor is described in section 3.7.1.3.

The 1st IF filter is tuned by three trimming coils and two transformers. The adjustment procedure for these components is described in section 3.7.1.1.

In this test of selectivity, the 6 dB bandwidth and the stop band attenuation is controlled. The test is performed by using variations in the level detector output voltage, which can be measured at testpoint TP1-1 in the AGC circuit. The voltage can be measured by using an analog multimeter, but it is easier to use a digital multimeter, because the variations in the level detector output voltage are relatively small (about 200 mV).

### 3.6.1. MODULE PERFORMANCE CHECK OF RECEIVER UNIT cont.:

#### SSB MODE

1. Connect the generator to the aerial socket at the front end unit (module 2).
2. Connect the voltmeter to testpoint TP1-1 for measuring the DC voltage at the level detector output.
3. Connect the counter to earpiece output at testpoint TP2-1.
4. Turn the RE2100 on.
5. Turn the RF gain control fully clockwise and make sure that the AGC is operative.
6. Choose generator frequency  $f_G$ , generator output level  $V_G$  and receiver frequency  $f_{RX}$  according to the table in point 20.
7. Make sure that J3E mode (SSB) is selected and that the AF signal frequency is approx. 1 kHz.
8. Wait 15 min. before proceeding, to temperature stabilize the receiver.
9. Turn off the AGC and adjust the manual RF GAIN Control to achieve a voltage of about 5 volt at testpoint TP1-1.
10. Finetune the receiver frequency by means of the arrow keys until maximum meter deflection, when measuring at testpoint TP1-1.
11. Readjust the manual RF GAIN to achieve a voltage of 5 volt at testpoint TP1-1.
12. To measure the 6 dB bandwidth, increase  $V_G$  by 6 dB and notice that the measured voltage will increase to about 14 volt.
13. Increase the receiver frequency by means of the upward arrow key until the voltage at testpoint TP1-1 is just about 5V.
14. Activate the clarifier function by pressing the <CLARIF> key and finetune the receiver frequency with the arrow keys until the voltage measured at testpoint TP1-1 is just above 5 volt. Now notice the receiver frequency in the display.
15. Deactivate the clarifier function by pressing the <CLARIF> key and decrease the receiver frequency by means of the downward arrow key until the measured voltage is just about 5V.
16. Repeat point 14.
17. Calculate the difference between the two frequencies found in points 14 and 16. This difference is equal to the 6 dB bandwidth, which must be above 2550 Hz.
18. To check the stopband attenuation, increase generator output level  $V_G$  by 20 dB relative to  $V_G$  in point 20.
19. Key-in the frequencies 1987.7 kHz and 1991.2 kHz and remember to turn off the AGC in each case. Control in both cases the DC voltage at testpoint TP1-1 to be below 5 volt.

3.6.1. MODULE PERFORMANCE CHECK OF RECEIVER UNIT cont.:

20.	Signal Generator			RE2100	
	$f_G$	$V_G(\text{EMF})$	Mode	$f_{RX}$	Mode
	1991 kHz	50 dB/uV	CW	1990 kHz	J3E (SSB)
	990 kHz	50 dB/uV	CW	990 kHz	H3E (AM)

**AM MODE**

21. Repeat points 1, 2 and 4-6.
22. Make sure that H3E mode (AM) is selected.
23. Repeat point 8-11.
24. Increase generator output level  $V_G$  by 6 dB.
25. To check the 6 dB bandwidth, key-in the frequencies 986,7 kHz and 993.3 kHz, and control in each case the voltage at testpoint TP1-1 to be above 5V. Remember in each case to turn off the AGC.
26. Increase generator output level  $V_G$  by 36 dB relative to  $V_G$  in point 20.
27. To check the stopband attenuation, key-in the frequencies 982,9 kHz and 997,1 kHz, and control in each case the voltage at testpoint TP1-1 to be below 5V. Remember in each case to turn off the AGC.

3.6.1.4. Check of 2nd IF Amplifier

In this test the gain of the 2nd IF amplifier is controlled by checking the threshold level of the Automatic Gain Control. This threshold level is defined in the figure below, where the AGC-characteristic is sketched.

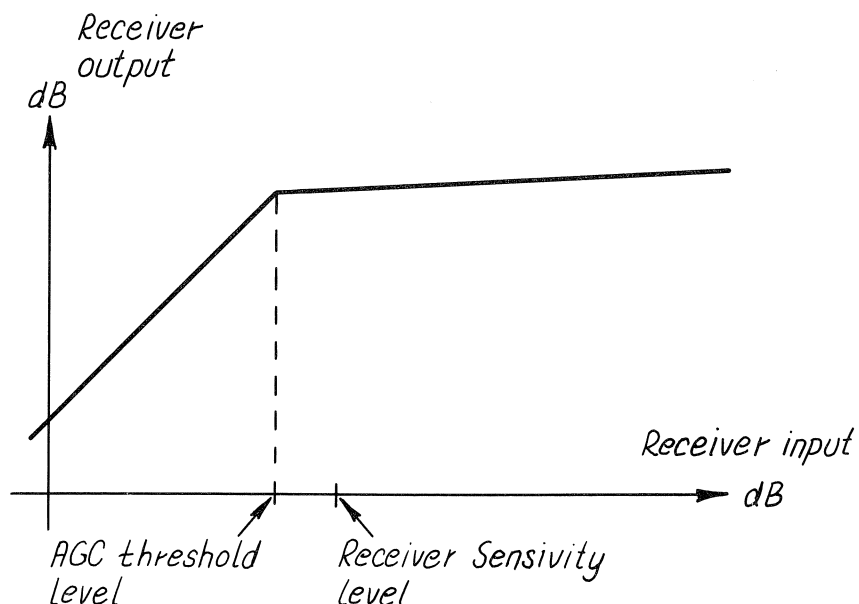

AGC-characteristic used to define the sensitivity or threshold level of the AGC.

### 3.6.1. MODULE PERFORMANCE CHECK OF RECEIVER UNIT cont.:

Below the threshold level the input signal is too weak to be detected by the AGC circuit. The gain of the 2nd IF amplifier is then unregulated and the receiver output level will increase as 1:1 with increasing input level.

Above the threshold level the input signal is large enough to be detected by the AGC. The gain of the 2nd IF amplifier will then be regulated and the output from the receiver will idealistically be kept at a constant level. However, in practice the receiver output level will increase slightly with increasing input level, because a constant output level would require an infinite gain of the 2nd IF amplifier.

The performance of the AGC above the threshold level is checked by measuring the "flatness" of the AGC characteristic. This measurement is also included in the check procedure given below, because it is measured in the same manner as the threshold level.

The threshold level must, as indicated in the AGC characteristic, be less than the sensitivity level of the receiver to ensure correct function of the AGC. The threshold level is determined by the level detector and the open loop gain from the aerial input to the level detector input. To study this in more details, the simplified block diagram is used in the following description.

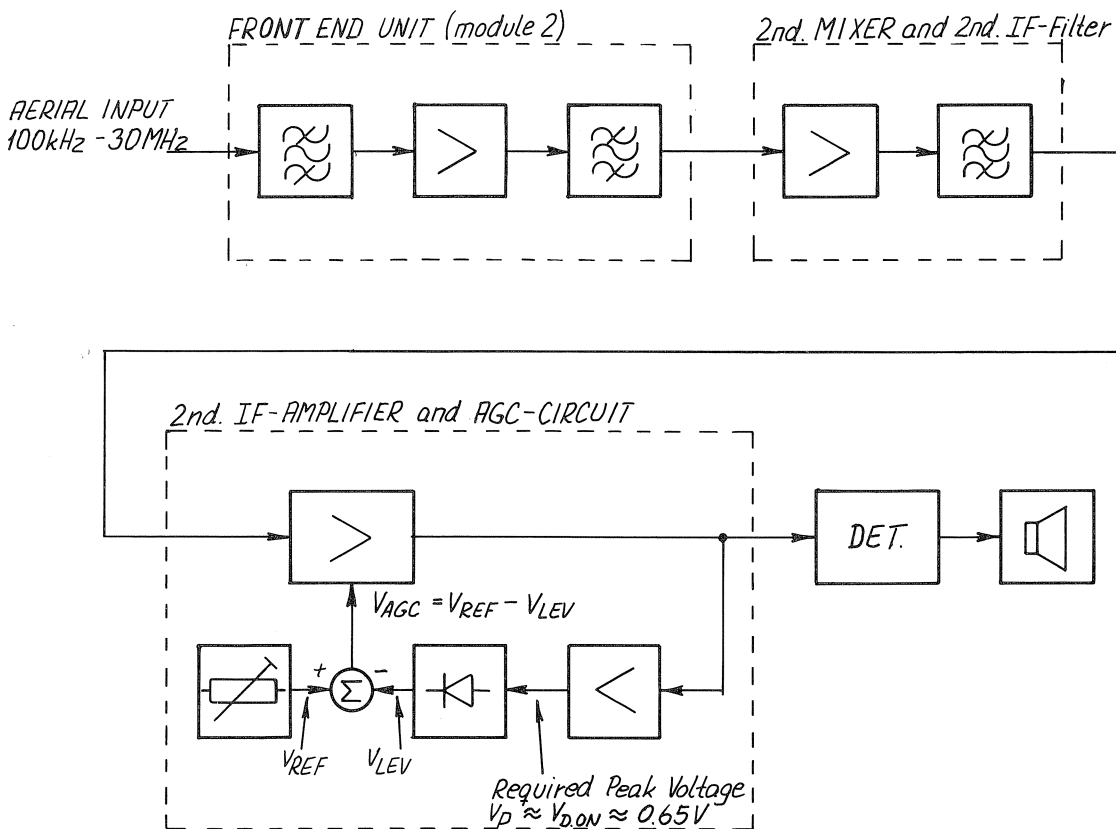

Simplified block diagram for the entire receiver.

### 3.6.1. MODULE PERFORMANCE CHECK OF RECEIVER UNIT cont.:

In the level detector, which is built-up around the transistor Q14-1, the base-emitter diode is used to convert the received AC signal to a DC signal. Thus the input voltage to the level detector is almost a constant and is equal to the diode cut-in voltage. The open loop gain from the aerial input to the level detector input must then be sufficiently high to produce the required peak voltage of about 0.65V with an input signal at the receiver sensitivity level.

In the simplified block diagram, the amplification from the aerial input to the level detector input is divided into four blocks, which are:

1. Front End Unit
2. 2nd Mixer plus 2nd IF Filter
3. 2nd IF Amplifier
4. AGC Amplifier.

If the receiver does not pass the test of the threshold level given below, it is probably caused by a loss of gain in one of the four blocks.

The gain of the Front End Unit can be controlled directly by the test procedure given in the section 3.6.2.5., while the gain of the 2nd mixer and the 2nd IF filter can only be controlled indirectly by the sensitivity test of the RX module given in section 3.6.1.1.

The gain of the AGC amplifier can be controlled by measuring the detector output level, which must be almost constant from one module to another, because of the rectifying diode in the level detector. To control the detector output level, use the check procedure given in section 3.6.1.6.

If the Front End Unit, the 2nd mixer and 2nd IF filter, and the AGC amplifier all perform as expected, the 2nd IF amplifier must finally be examined. The problem may be solved by adjusting the reference voltage  $V_{REF}$  in the AGC circuit. The adjustment is performed by the trimming resistor R203-1 and is described in section 3.7.1.4.

1. Connect the generator to the aerial socket at the front end unit (module 2).
2. Connect the voltmeter to testpoint TP2-1 for measuring the AC voltage at the earpiece output.
3. Turn the RE2100 on and turn the RF gain control fully clockwise.
4. Choose generator frequency  $f_G$ , generator output level  $V_G$ , and receiver frequency  $f_{RX}$  according to point 9.
5. Measure the signal to noise ratio  $SND/N$  at the earpiece output (see section 3.5.2.1., point 6 for instructions about how to measure  $SND/N$ ). If the signal to noise ratio  $SND/N$  is different from 20 dB, the generator output level must be adjusted until this value is obtained.
6. Notice the earpiece output at testpoint TP2-1.
7. To control the threshold level of the AGC, increase the generator output level  $V_G$  by 20 dB and control that the earpiece output level does not increase by more than 2 dB relative to the level measured in point 6.
8. To control the flatness of the AGC, increase the generator output level  $V_G$  by 50 dB so the total increase is 70 dB. Control that the earpiece output level does not increase by more than 3 dB relative to the level measured in point 6.

### 3.6.1. MODULE PERFORMANCE CHECK OF RECEIVER UNIT cont.:

Signal Generator			RE2100	
$f_G$	$V_G(\text{EMF})$	Mode	$f_{RX}$	Mode
1991 kHz	7dB/uV	CW	1990 kHz	J3E (SSB)

#### 3.6.1.5. Check of AGC Circuit

In this test the attack and decay time of the automatic gain control is controlled by measuring the step response of the AGC circuit.

In J3E mode (SSB) the attack time is determined by the resistors R89-1, R91-1 and capacitor C72-1, while the decay time is determined by R63-1 and C69-1.

In H3E mode (AM) the attack time and decay time are determined by R89-1, R91-1 and C71-1.

The measurement of step response is performed by a sudden increment or decrement of the RF input level. This step in input level is obtained by toggling the RX mute relay, which is located at the front end unit. The relay is controlled by two different service programmes.

The step response will be displayed on an oscilloscope, which with advantage may be a storagescope.

1. Connect the generator to aerial socket at the front end unit (module 2).
2. Connect the oscilloscope to testpoint TP3-1 for measuring the AGC voltage and select AC coupling.
3. Connect a probe from testpoint TP4-2 (collector of transistor Q01-2, located at front end unit) to the external trigger input on the oscilloscope.
4. Select external trig source, DC trig mode, and negative slope trig.
5. Turn the RE2100 on and turn the RF gain control fully clockwise.
6. Choose generator frequency and generator output level  $V_G$  as specified in point 12.
7. In points 8-10 the AGC responses are measured with the oscilloscope and they must be similar to the responses shown below.  
NOTE! It may be necessary to adjust trig level to obtain an image on the oscilloscope.
8. To measure the attack time in J3E mode, select service programme SP-04-6.
9. To measure the decay time in J3E mode, select service programme SP-04-6 and change the setting of the oscilloscope.  
NOTE! To change service programme press <STOP>.
10. To measure the attack and decay time in H3E mode, select service programme SP-04-7 and change the setting of the oscilloscope. Select positive slope trig.
11. Press <TUNE> to leave service programme mode.

### 3.6.1. MODULE PERFORMANCE CHECK OF RECEIVER UNIT cont.:

12.

Signal Generator			RE2100	
$f_G$	$V_G$ (EMF)	Mode	$f_{RX}$	Mode
1991 kHz	70 dB/uV	CW	1990 kHz	J3E (SSB)
1991 kHz	70 dB/uV	AM mod. 30% with 1 kHz	1991 kHz	H3E (AM)

The RE2100 is automatically set by the service programmes.

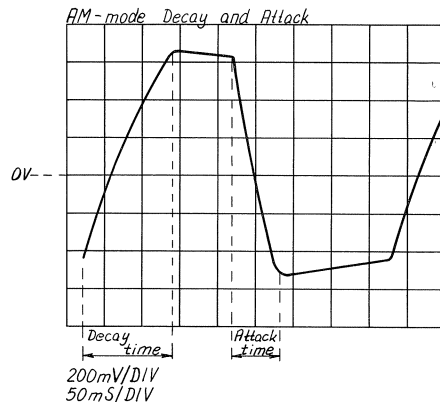
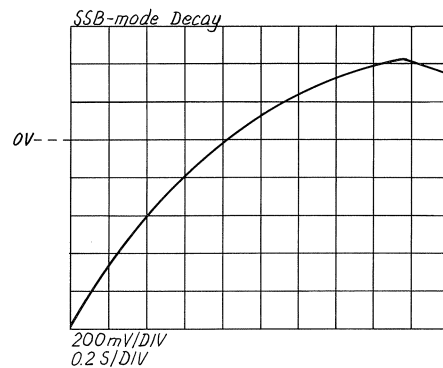
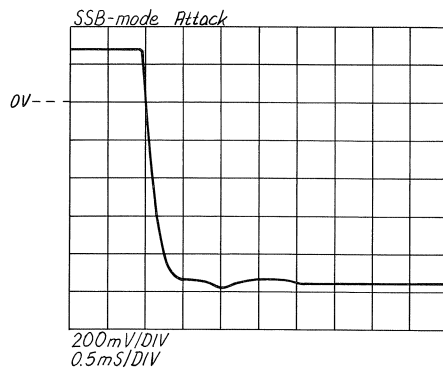

AGC Step Responses.

#### 3.6.1.6. Check of Detector

In this section the audio frequency output level and distortion from the detector are controlled.

The output level from the detector is determined by the input level to the detector and by the detector itself.

The input level to the detector is given by the base-to-emitter voltage of transistor Q14-1 divided by the voltage gain of the AGC amplifier, which is built-up around transistor Q16-1.

1. Connect the generator to the aerial socket at the front end unit (module 2).
2. Connect the voltmeter and a distortion meter to detector output at U06, pin 6.

### 3.6.1. MODULE PERFORMANCE CHECK OF RECEIVER UNIT cont.:

3. Turn the RE2100 on, and turn the RF gain control fully clockwise.
4. Choose generator frequency  $f_G$ , generator output level  $V_G$ , and receiver frequency  $f_{RX}$  according to point 6.
5. Measure the AF output level and distortion at detector output and control the result by comparing it to the values given in point 6.

Signal Generator			RE2100		Detector Output	
$f_G$	$V_G$ (EMF)	Mode	$f_{RX}$	Mode	Level	Distortion
1991 kHz	70dB/uV	CW	1990 kHz	J3E(SSB)	600 mV <sub>RMS</sub> -800 mV <sub>RMS</sub>	1.5%
1991 kHz	70dB/uV	AM-mod. 30% with 1 kHz	1991 kHz	H3E(AM)	75mV <sub>RMS</sub> -95mV <sub>RMS</sub>	2%

#### 3.6.1.7. Check of AF Filters

The audio frequency selectivity is controlled by measuring the overall selectivity of the receiver.

If the measured data cannot fulfil the specified requirements, it is necessary to control the 2nd IF selectivity before any conclusion can be made.

#### SSB MODE

1. Connect the generator to the aerial socket at the front end unit (module 2).
2. Connect the voltmeter and the counter to testpoint TP2-1 (earpiece output).
3. Turn the RE2100 on and turn the RF gain control fully clockwise.
4. Choose generator frequency  $f_G$ , generator output level  $V_G$ , and receiver frequency  $f_{RX}$  according to point 11.
5. Make sure that J3E mode (SSB) is selected, that AGC is on, and that the AF signal frequency is approx. 1 kHz.
6. Finetune the receiver frequency by means of the arrow keys until maximum meter deflection when measuring at testpoint TP2-1.
7. Notice the AC voltage at testpoint TP2-1.
8. Turn the AGC off and adjust the RF gain control to achieve the output level found in point 7.
9. To check the 6 dB bandwidth, choose the generator frequencies 1990.35 kHz and 1992,70 kHz and control in each case the AC voltage at testpoint TP2-1 not to decrease more than 6 dB relative to the value measured in point 7.



### 3.6.1. MODULE PERFORMANCE CHECK OF RECEIVER UNIT cont.:

10. To check the stopband attenuation, choose the generator frequency 1993,1 kHz and control the AC voltage at testpoint TP2-1 to decrease more than 20 dB relative to the value measured in point 7.

11.	Signal Generator			RE2100	
	$f_G$	$V_G(\text{EMF})$	Mode	$f_{RX}$	Mode
	1991 kHz	70 dB/uV	CW	1990 kHz	J3E (SSB)
	1991 kHz	70 dB/uV	AM mode 30% with 1 kHz	1991 kHz	H3E (AM)

#### AM MODE

12. Repeat point 1-4.
13. Make sure that H3E mode (AM) is selected, that AGC is on, and that the AF signal frequency is approx. 1 kHz.
14. Finetune the receiver frequency by means of the arrow keys until maximum meter deflection at testpoint TP2-1.
15. Notice the AC voltage at testpoint TP2-1.
16. To check the 6 dB bandwidth, change the modulation frequency of the generator to 100 Hz and 3000 Hz, and control in each case the AC voltage at testpoint TP2-1 not to decrease more than 6 dB relative to the value measured in point 15.
17. To check the stopband attenuation, change the modulation frequency of the generator to 6 kHz and control the AC voltage at testpoint TP2-1 to decrease more than 40 dB relative to the value measured in point 15.

#### 3.6.1.8. Check of Earpiece Amplifier

The purpose of this test is to control the earpiece amplifier, which is built-up around the integrated circuit U07. If the earpiece output level is outside the specified range, it is necessary to re-adjust the trimming resistor R52-1, which is located at the receiver unit. If it is not possible to adjust the output level to be within the specified range, it is necessary to control the detector output level before any conclusion can be made.

1. Connect the generator to the aerial socket at the front end unit (module 2).
2. Connect the voltmeter and the distortion meter to earpiece output at testpoint TP2-1.
3. Turn the RE2100 on and turn the RF gain control fully clockwise.
4. Choose generator frequency  $f_G$ , generator output level  $V_G$ , and receiver frequency  $f_{RX}$  according to point 7.

### 3.6.1. MODULE PERFORMANCE CHECK OF RECEIVER UNIT cont.:

5. Measure the earpiece output level at testpoint TP2-1 and control the result to be within the range  $0.7V_{RMS}$  -  $0.9V_{RMS}$ .
6. Measure the earpiece output distortion at testpoint TP2-1 and control the result to be less than 1.5%.

7.

Signal Generator			RE2100	
$f_G$	$V_G(EMF)$	Mode	$f_{RX}$	Mode
1991 kHz	70dB/uV	CW	1990 kHz	J3E (SSB)

#### 3.6.1.9. Check of Squelch Circuit

The squelch circuit in the RE2100 is voice activated and it works in principle by detecting deviations in the frequency of the received signal. This relative complex squelch function is implemented by means of four separate blocks, which are:

1. Limiting amplifier
2. Frequency to Voltage Converter
3. Voltage Change Detector
4. Hold Circuit

The output voltage from the Hold Circuit is sensed by the microprocessor and this unit is then controlling the analog switch, which is used to mute the audio frequency output.

In the check procedure given below only the analog part of the squelch is controlled and if this is performing as expected, a failure may be caused by the microprocessor or the connection cabling.

1. Connect the generator to the aerial socket at the front end unit.
2. Connect a handset or loudspeaker to the testbox or directly to the RE2100.
3. Turn the RE2100 on and turn the RF gain control fully clockwise.
4. Choose generator frequency  $f_G$ ; generator output level  $V_G$ , and receiver frequency  $f_{RX}$  as specified in point 15.
5. Switch off the squelch and make sure that you now hear a 1600 Hz tone.
6. To control the limiting amplifier connect the oscilloscope to the output of the operational amplifier U02/1, pin 1. Control the measured signal to be squarewave with a frequency of 1600 Hz and an amplitude of about 13Vpp.
7. To control the frequency to voltage converter, connect the voltmeter to the output of the operational amplifier U02/4, pin 14 and control the DC voltage to be about 7V.
8. Increase the generator frequency with 1 kHz and control the DC voltage at U02/4, pin 14, to increase to about 11V. Decrease the generator frequency with 2 kHz ( $f_G = 1990.6$  kHz) and control the DC voltage to decrease to about 4V.

### 3.6.1. MODULE PERFORMANCE CHECK OF RECEIVER UNIT cont.:

9. To control the voltage change detector, connect the oscilloscope to the output of the operational amplifier U01/4, pin 14. Select DC trig mode and positive slope trig.
10. Change the generator frequency with +1 kHz relative to the frequency specified in point 15 and control in each case the voltage change detector to generate an impulse with a magnitude of about 13V and a duration of about 350 msec.
11. To control the Hold Circuit, choose the generator frequency specified in point 15, and switch on the squelch.
12. Connect the voltmeter to the output of the operational amplifier U01/1, pin 1.
13. Decrease the generator frequency with 1 kHz and control the DC voltage at U01/1, pin 1 to be about 13V. You will now hear a 600 Hz tone in your handset or loudspeaker.
14. Control the DC voltage at U01/1, pin 1 to fall to 0V after a time period of about 10 secs and control that the audio frequency output is muted.

15.

Signal Generator			RE2100	
$f_G$	$V_G(\text{EMF})$	Mode	$f_{RX}$	Mode
1991.6 kHz	70 dB/uV	CW	1990 kHz	J3E (SSB)

## 3.6.2. MODULE PERFORMANCE CHECK OF FRONT END UNIT

This chapter contains the following sections:

- 3.6.2.1. Check of Sensitivity (RE2100)
- 3.6.2.2. Check of Front End Gain
- 3.6.2.3. Check of Mute and RX/TX Switch
- 3.6.2.4. Check of Selection Circuit for Pre-Filters
- 3.6.2.5. Check of L01 Signal and Buffer

### 3.6.2.1. Check of Sensitivity (RE2100)

The sensitivity of the entire receiver can in J3E mode be calculated from the following equation:

$$\text{SENS} \approx 10 \log \left( F_{\text{front}} + \frac{F_{\text{RX}} - 1}{G_{\text{front}}} \right) - 7 \text{ dB} \quad (\text{dB/uV})$$

where the following figures shall be taken as typical values:

- $F_{\text{front}} = 5.2 \approx 7.2 \text{ dB}$  : Noise factor and figure for Front End
- $F_{\text{RX}} = 6.3 \approx 8.0 \text{ dB}$  : Noise factor and figure for Receiver
- $G_{\text{front}} = 0.5 \approx -3.0 \text{ dB}$  : Available power gain for Front End

The equation is only valid when using a single tone SSB test signal, which produces a signal to noise ratio of 20 dB at the receiver output, and when using a signal generator with an impedance of 50 ohm.

From the figures it can be seen that both the Front End Unit and the Receiver Unit are determining the sensitivity level.

To exclude the receiver unit, it is necessary to check the sensitivity level of this unit separately, which can be done by means of the check procedure described in section 3.6.1.1.

The available power gain,  $G_{\text{front}}$ , of the Front End Unit can be controlled by the check procedure given in the next section (3.6.2.2.).

The check procedure in this section is especially useful to control the insertion loss of the six parallel coupled bandpass filters, which are used as pre-filters in the Front End Unit. If the sensitivity is poor in only one band, it is very likely that the corresponding filter or the filter selection circuit has a failure.

The filter selection circuit can be checked by means of the check procedure given in section 3.6.2.3.

1. Connect the generator to the aerial socket through the 50 ohm impedance matching network shown in chapter 3.3. PROPOSAL FOR NECESSARY TEST EQUIPMENT.
2. Connect the voltmeter to the earpiece output at testpoint TP2-1 for measuring the AC voltage.
3. Turn the RE2100 on.

3.6.2. MODULE PERFORMANCE CHECK OF FRONT END UNIT cont.:

4. Choose generator frequency  $f_G$ , generator output level  $V_G$ , and Receiver frequency  $f_{RX}$  as specified in point 6.
5. Measure the signal to noise ratio  $SND/N$  at the earpiece output and check that it is above 20 dB. (See section 3.5.2.1., point 6 for instructions about how to measure  $SND/N$ ).

6.

Pre-filter number	Signal Generator		RE2100		
	$f_G$ (kHz)	$V_G$ (EMF)	Mode	$f_{RX}$	Mode
1	101	18 dB/uV	CW	100	J3E USB
	385	10 dB/uV		384	
2	386	10 dB/uV		385	
	1600	8 dB/uV		1599	
	995	23 dB/uV	AM 30% with 1 kHz	995	H3E
3	1601	8 dB/uV	CW	1600	J3E USB
	4500	8 dB/uV		4499	
	2182	23 dB/uV	AM 30% with 1 kHz	2182	H3E
4	4501	8 dB/uV	CW	4500	J3E USB
	9000	8 dB/uV		8999	
5	9001	8 dB/uV		9000	
	18000	9 dB/uV		17999	
	12352	8 dB/uV		12353	J3E LSB
6	18001	9 dB/uV		18000	J3E USB
	29981	9 dB/uV	29980		
	18373	23 dB/uV	AM 30% with 1 kHz	18373	H3E

**NOTE!** The signal levels given in point 6 are referring to the output of the 50 ohm impedance matching network, which has an EMF insertion loss of 20 dB. To obtain the setting of the signal generator, the insertion loss of 20 dB must be added to the levels given in point 6.

3.6.2.2. Check of Front End Gain

In this test the available power gain of the Front End Unit is controlled. The gain is determined by an indirect measurement and it is therefore necessary to correct the measured data afterwards.

### 3.6.2. MODULE PERFORMANCE CHECK OF FRONT END UNIT cont.:

In the test procedure given below, the input and output levels of the Front End Unit are measured by means of the diode probe. To avoid mistuning of the 70 MHz output filter, because of the capacitive loading introduced by the diode probe, it is necessary to measure the output level through a voltage divider. The Front End Unit must then be terminated as shown in the figures below, where the wanted loading impedance of 800 ohm is realized with a voltage divider consisting of a resistor of 750 ohm in series connection with a resistor of 50 ohm.

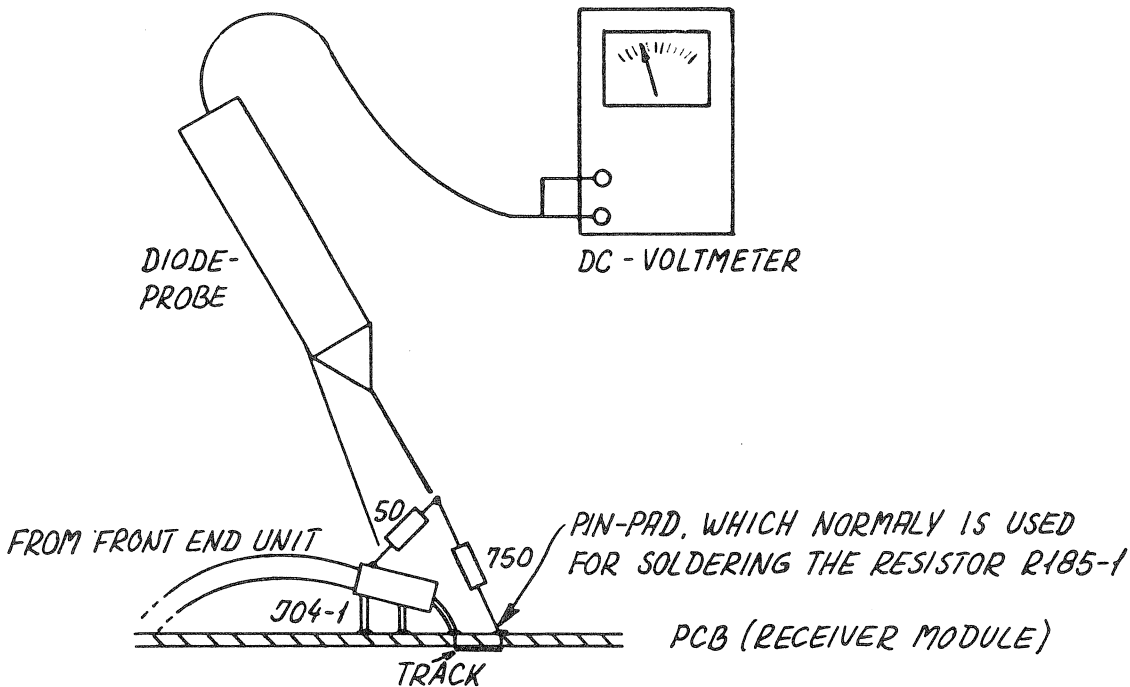

Termination of the Front End Unit for measurement of the available power gain. The termination is realized at the Receiver Unit (module 1).

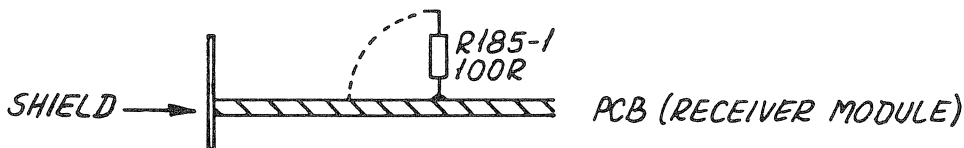

The resistor R185-1 must be disconnected as shown above, before the termination of the Front End Unit can be implemented.

1. Terminate the Front End Unit as shown in the figures above.
2. Turn the RE2100 on.
3. Choose generator frequency  $f_G$ , generator output level  $V_G$ , and receiver frequency  $f_{RX}$  as specified in point 10.
4. Connect the diode probe across the 50 ohm resistor in the Front End terminating network (see figure above).
5. Notice the diode probe voltage.
6. Connect the diode probe across the neon lamp at the input of the front end unit.

### 3.6.2. MODULE PERFORMANCE CHECK OF FRONT END UNIT cont.:

7. Adjust the signal generator level  $V_G$  until the diode probe voltage is equal to the value measured in point 5.
8. Calculate the difference between the signal generator level used in point 3 and the level found in point 7.
9. The available power gain of the front end unit can now be calculated by means of the equation

$$G_{\text{front}} = 12 \text{ dB} - \Delta V_G$$

where  $\Delta V_G$  is the difference in generator level found in point 8. The gain should be  $-2 \text{ dB} \pm 2 \text{ dB}$ .

10.

Signal Generator			RE2100	
$f_G$	$V_G$ (EMF)	Mode	$f_{RX}$	Mode
1991 kHz	120 dB/uV	CW	1990 kHz	J3E (SSB)

#### 3.6.2.3. Check of Mute and RX/TX Switch

The mute relay RE01-2 is used for external mute functions and for protection of the Front End Unit, when the RE2100 is switched off. The mute function is checked by toggling the relay RE01, which is done by means of the service programme SP-04-6.

The RX/TX relay RE02-2 is used for switching between receiver and transmitter mode. The RX/TX relay is normally in the non-activated state, which corresponds to RX-mode. To obtain the TX-mode, the relay must be activated. This can only be done by means of a service programme, when the RE2100 is disconnected from the transmitter T2130.

1. To check the mute relay, connect the signal generator to the aerial socket at the Front End Unit.
2. Choose the generator frequency  $f_G = 1991 \text{ kHz}$  and the generator level,  $V_G = 70 \text{ dB/uV}$ .
3. Select the service programme SP-04-6 and control the number of lighted LED's in the signal strength meter to change between about five and eight with a time interval of about 2 secs.  
NOTE! Make sure that the signal strength meter is correctly adjusted.
4. To check the RX/TX relay connect a handset to the RE2100 for keying the exciter. If a testbox is available, this can be used instead.
5. Connect the voltmeter through diode probe to the aerial socket at the front end unit.
6. Select the service programme SP-05-0 and key the exciter.
7. Control the DC-voltage measured through the diode probe at the aerial socket to be  $6V \pm 1V$ .
8. To leave service programme mode press <TUNE>.

### 3.6.2. MODULE PERFORMANCE CHECK OF FRONT END UNIT cont.:

#### 3.6.2.4. Check of Selection Circuit for Pre-Filters

The switching between the pre-filters is controlled from the microprocessor through the shift register J01-2 and six operational amplifiers which are included in the two IC's U02-2 and U03-2.

1. Key-in the receiver frequencies and control the DC-voltage at the output of U02-2 and U03-2 to be in accordance with the table in point 2.

2.

Receiver Frequency (kHz)	U02				U03	
	pin 1	pin 7	pin 8	pin 14	pin 1	pin 7
196	0V	0V	0V	0V	0V	13V
785	0V	0V	0V	0V	13V	0V
2683	0V	0V	0V	13V	0V	0V
6364	0V	0V	13V	0V	0V	0V
12728	0V	13V	0V	0V	0V	0V
23238	13V	0V	0V	0V	0V	0V

#### 3.6.2.5. Check of L01 Signal and Buffer

In this test the level of the L01 signal at the output of the buffer is controlled.

The L01 signal is used in the mixing process from the receiver frequency  $f_{RX}$  to the 1st IF at 70,000,640 MHz.

The frequency of the L01 signal can be varied from 70 MHz to 100 MHz and is determined by the equation:

$$f_{L01} = f_{RX} + f_{IF1} = f_{RX} + 70,000,640 \text{ MHz}$$

where  $f_{RX}$  is the receiver frequency.

1. Connect the voltmeter through the diode probe across the coil L41-2.
2. Turn the RE2100 on.
3. Key-in the receiver frequency 2182 kHz.
4. Control the measured DC voltage to be 7.5V  $\pm$ 1V.



### 3.6.3. MODULE PERFORMANCE CHECK OF SYNTHESIZER UNIT

This chapter contains the following sections:

- 3.6.3.1. Check of TCXO
- 3.6.3.2. Check of PLL1
- 3.6.3.3. Check of PLL2

#### 3.6.3.1. Check of TCXO

The TCXO signal is used as reference frequency in both PLL1 and PLL2, and it is also used as carrier injection signal for both transmitter and receiver.

1. Turn the RE2100 on.  
**NOTE!** The RE2100 must be on for at least 15 minutes before the check is carried out.
2. Connect the counter to TP4-3 through passive probe.
3. Check the frequency on TP4-3 to be 10.731520 MHz  $\pm$ 1 Hz.

#### 3.6.3.2. Check of PLL1

The PLL1 consists of four independent VCO's, which together cover the whole frequency band from 70 MHz to 100 MHz.

1. Turn the RE2100 on.
2. Connect the voltmeter to TP1-3.
3. Connect the counter to TP3-3.
4. Key-in the RX frequency and check the DC-voltage on TP1-3 and the frequency on TP3-3 to be in accordance with table in point 5.
- 5.

RX-frequency	Frequency on TP3-3	Voltage on TP1-3
7499.0	77.49964 MHz $\pm$ 10 Hz	-11.0V $\pm$ 1V
14999.0	84.99964 MHz $\pm$ 10 Hz	-11.0V $\pm$ 1V
22499.0	92.49964 MHz $\pm$ 10 Hz	-11.0V $\pm$ 1V
29999.0	99.99964 MHz $\pm$ 10 HZ	-11.0V $\pm$ 1V

6. Key in the RX-frequency and check the DC-voltage on TP1-3 and the frequency on TP3-3 to be in accordance with point 7.

### 3.6.3. MODULE PERFORMANCE CHECK OF SYNTHESIZER UNIT cont.:

7.

RX-frequency	Frequency on TP3-3	Voltage on TP1-3
100.0	70.10064 MHz $\pm 10$ Hz	-3.0V $\pm 1.0$ V
7500.0	77.50064 MHz $\pm 10$ Hz	-3.0V $\pm 1.0$ V
15000.0	85.00064 MHz $\pm 10$ Hz	-3.0V $\pm 1.0$ V
22500.0	92.50064 MHz $\pm 10$ Hz	-3.0V $\pm 1.0$ V

8. Select RX-frequency 2225.4 kHz and measure the frequency on TP3-3.
9. Select RX-frequency 2075.3 kHz and measure the frequency on TP3-3, then subtract it from the frequency measured in check point 8. The result must be 150.100 kHz  $\pm 2$  Hz.
10. Connect the voltmeter to TP3-3 through diode probe.
11. Select RX-frequency and check the voltage on TP3-3 to be in accordance with point 12.

12.

RX-frequency	Voltage on TP3-3
3750.0	>0.8 Volt
11250.0	>0.8 Volt
18750.0	>0.8 Volt
26250.0	>0.8 Volt

13. Connect the voltmeter to TP2-3 through diode probe.
14. Select service programme SP-04-5 as described in this manual, section 3.10.1. and check the voltage on TP2-3 to be above 0.8 Volt.

#### 3.6.3.3. Check of PLL2

The PLL2 consists of two independent VCO's and is capable of delivering two different signals with the frequencies 59.26912 MHz and 80.73216 MHz.

1. Turn the RE2100 on.
2. Connect the voltmeter to TP5-3.
3. Connect the counter to TP7-3.
4. Select receiver mode and check the DC-voltage on TP5-3 and the frequency on TP7-3 to be in accordance with point 5.

5.

Mode	Frequency on TP7-3	Voltage on TP5-3
J3E	59.26912 MHz $\pm 10$ Hz	-6.5V $\pm 0.5$ V
LSB	80.73216 MHz $\pm 10$ Hz	-6.5V $\pm 0.5$ V

### 3.6.3. MODULE PERFORMANCE CHECK OF SYNTHESIZER UNIT cont.:

6. Connect the voltmeter to TP7-3 through diode probe.
7. Check the voltage on TP7-3 to be in accordance with table 8.

8.

Mode	Voltage on TP7-3
J3E	>0.8 Volt
LSB	>0.8 Volt

9. Connect the voltmeter to TP6-3 through diode probe.
10. Select service programme SP-04-5 as described in this manual, section 3.10.1., and check the voltage on TP6-3 to be above 0.8 Volt.

## 3.6.4. MODULE PERFORMANCE CHECK OF EXCITER UNIT

This chapter contains the following sections:

- 3.6.4.1. Check of Compressor and AF Limiter
- 3.6.4.2. Check of Carrier Limiter Amplifier
- 3.6.4.3. Check of Modulator
- 3.6.4.4. Check of SSB Filter
- 3.6.4.5. Check of RF Limiter and Carrier Insertion
- 3.6.4.6. Check of Step Attenuator
- 3.6.4.7. Check of 70 MHz IF and LO Injection

Any value, which differs too much from the values given in this chapter should lead to an adjustment of the circuit in question. Please, see chapter 3.7.3. ADJUSTMENT PROCEDURE FOR EXCITER UNIT

How to select service programmes is described in the chapter 3.10.

### 3.6.4.1. Check of Compressor and AF Limiter

1. Connect a tone generator (1000 Hz) to the testbox at the BNC-socket "AF to TX". If a testbox is not available, connect the tone generator directly to the handset plug on the RE2100 (to J03-2, pin 4). Connect it with a capacitor 22 uF/25V because of the DC voltage on the microphone terminal.
2. Connect a scope probe to Q04-4 emitter (TP1-4).
3. Select service programme SP-05-1 and select J3E mode.
4. Adjust the tone generator output voltage from a minimum until the level at the scope is just constant. This limitation must happen at approx. 0.1Vpp measured at the handset plug J03-2, pin 4.
5. Check that the voltage at Q04-4 (TP1-4) stays approx. at the same level when increasing the tone generator 20 dB to 1Vpp.
6. Select service programme SP-05-0.
7. Connect scope probe to R07-4 and read approx. 0.5 Vpp (tune tones).
8. Connect scope probe to Q04-4 emitter (TP1-4).
9. Connect R34-4 (TP7-4) to ground (chassis). That is a short-circuit of R34-4, which means that the signal exceeds the cutting level.
10. Adjust the scope to full deflection (8 div).
11. Disconnect the grounding of R34-3 and read the peak-peak deflection to 6.9 div.  $\pm$  0.3 div.

### 3.6.4. MODULE PERFORMANCE CHECK OF EXCITER UNIT cont.:

#### 3.6.4.2. Check of Carrier Limiter Amplifier

1. Select service programme SP-05-0 and press handset key.
2. Connect a scope probe to J01-4 and measure the carrier injection to approx. 0.1Vpp.
3. Connect scope probe to the connection between R93-4 and C75-4 (TP2-4) and read the voltage to 1,55Vpp  $\pm$ 0.1V.

#### 3.6.4.3. Check of Modulator

1. Select service programme SP-05-0 and press handset key.
2. Connect a scope probe to U06-4, pin 10 and read approx. 0.17Vpp.
3. Connect scope probe to U06-4, pin 1 and read approx. 0.75 Vpp.
4. Connect scope probe to the connection between C66-4 and C67-4 (TP3-4) and read the voltage to 6.6 Vpp  $\pm$ 0.3V.

#### 3.6.4.4. Check of SSB Filter

1. Connect a tone generator to the testbox at the .BNC-socket "AF to TX". If a testbox is not available, connect the tone generator directly to the handset plug on the RE2100 (to J03-2, pin 4). Connect it with a capacitor 22 uF/25V because of the DC voltage on the microphone terminal. Set the tone generator output level to 0.3 Vpp.
2. Select service programme SP-05-1 and select J3E mode on the keyboard.
3. Press handset key.
4. Connect a scope probe to Q19-4 emitter (TP4-4).
5. Control of SSB filter response is carried out by changing the frequency of the tone generator and controlling the reading on the scope. Max. permissible ripple is 2 dB in the frequency range 500 Hz to 2500 Hz and the -6 dB frequency is approx. 350 Hz and 2700 Hz.

#### 3.6.4.5. Check of RF Limiter and Carrier Insertion

1. Select service programme SP-05-0 and press handset key.
2. Connect the scope probe to Q19-4 emitter (TR4-4) and read the voltage to approx. 1.5Vpp.
3. Short-circuit R34-4 (TP7-4) to ground, and the signal seen on the scope is now cut.
4. Adjust the scope until full deflection (8 div) of the cut signal is seen on the scope screen.
5. Disconnect the grounding of R34-4 and read on the scope the peak-peak voltage to be 7.2 div.  $\pm$ 0.2 div.

#### 3.6.4. MODULE PERFORMANCE CHECK OF EXCITER UNIT cont.:

6. Adjust the scope until full deflection of the signal is seen on the scope screen.
7. Select service programme SP-05-1 and press handset key.
8. Select H3E mode on the keyboard.
9. Check on the scope that the signal is 4.4 div.  $\pm 0.3$  div.
10. Select R3E mode on the keyboard.
11. Check on the scope that the signal is 1.2 div.  $\pm 0.2$  div.

##### 3.6.4.6. Check of Step Attenuator

1. Select service programme SP-05-0 and press handset key.
2. Connect a scope probe to R169-4 (TP5-4) and read the signal to 0.55Vpp  $\pm 0.05$ V.
3. In order to check the linearity of the step attenuator, please see section 3.7.3.6. points 6-9.

##### 3.6.4.7. Check of 70 MHz IF and LO Injection

1. Select service programme SP-05-3 and H3E mode.
2. Press handset key.
3. Place a diode probe on top of Q17-4 and read approx. 0.95V.
4. Select service programme SP-05-1 and H3E mode and press handset key.
5. Place the diode probe on top of Q17-4 and read approx. 1.25V.
6. Select service programme SP-05-0 and press handset key.
7. Place a diode probe on J02-4 and read approx. 1.4V.
8. Place the diode probe on top of Q17-4 and read approx. 1.75V.
9. Place the diode probe on J04-4 and read 1.8V.
10. Place the diode probe on top of Q24-4 and read approx. 13.5V.

## 3.6.5 PERFORMANCE CHECK OF MICROPROCESSOR MODULE 5.

### GENERAL

To execute a performance check of a microprocessor unit, keyboard unit and display unit (module 5, 6 and 7) it is necessary to dismantle the cover and remove the 2 PCB covers on module 5. Disconnect the BNC and 25 poles D-connector to T2130. Connect an external +18V power supply at J03 pin 12 or pin 24, an external -18V power supply at J03 pin 10 and an adjustable +9V power supply at J03 pin 11 or pin 23.

### CHECK OF ON BOARD POWER SUPPLY

Connect a voltmeter between ground and anode of D02. Control the voltage to  $> 7.0V$ . Normally  $9.0V$ .

Connect a voltmeter between ground and U15 pin 2. Control the voltage:  $4.75V < +5VA < 5.25V$ .

Connect a voltmeter between ground and U17 pin 3. Control the voltage:  $4.50V < +5VB < 5.50V$ .

Connect a voltmeter between ground and U18 pin 3. Control the voltage:  $-4.50V > -5VB > -5.50V$ .

### CHECK OF MICROPROCESSOR

#### Control of Strap in P02.

If the strap is connected between pin 1 and pin 2, the microprocessor will read the programme from internal ROM. This is only used if the microprocessor U07 is mask programmed. In that case the ROM U06 will not be mounted. If the strap is connected between pin 2 and pin 3, the microprocessor will read the programme from U06.

#### Control of Strap in P03.

If the strap is connected between pin 1 and pin 2, the microprocessor will run in service programme mode. The display will read out "SP- ". Look up the description of Service Programmes in chapter 3.10. If the strap is connected between pin 2 and pin 3, the microprocessor will run the normal programme.

#### Control of the Internal Clock Frequency.

Connect a frequency counter to U07 pin 64. The frequency must be  $2000 \text{ kHz} \pm 16.0 \text{ kHz} (X-tal/4)$ .

### CHECK OF EXTERNAL ROM

If the microprocessor is strapped to external ROM, control the strap in P01. If the strap is connected between pin 1 and pin 2, the device (ROM) in socket U06 must be a 256 Kbyte type (e.g. 27C256). If the strap is connected between pin 2 and pin 3, the device (ROM) in socket U06 must be a 128 Kbyte type (e.g. 27C128).

### 3.6.5. PERFORMANCE CHECK OF MICROPROCESSOR MODULE 5 cont.

#### CHECK OF POWER LOW CIRCUIT AND WATCH DOG CIRCUIT

##### Control of Power Low Circuit

Adjust the 9V external power supply to 9.0V. When the power is switched on, control that the display will read out "Error20" (there is no connection to T2130). Press the distress key (2182), and the display will now read out "\_2182.0". Turn the 9V power supply down slowly and control the power voltage. When the display reads out "Error00" (the 9V power supply is too low) the power supply must be approx. 7.0V.

##### Control of Watch Dog Circuit.

Adjust the 9V power supply to approx. 9.0V. Connect an oscilloscope to U15 pin 6 and control that the square wave seen has a 5.0V +/- 0.5V amplitude, that the duty cycle is 50%, and that the frequency is one of 3 possible:

1. 15 Hz. Standard after power is switched on.
2. 20 Hz. Standard for Test Alarm mode.
3. 50 Hz. Standard for Scan Run mode.

Connect a test wire between ground and U15 pin 6. Control that the microprocessor will start a reset cycle after every 1.6 s. (the display will flash an "Error20". Disconnect the test wire again and control that the microprocessor will stop the reset cycle.

#### CHECK OF BAUD RATE GENERATOR

Connect a frequency counter to U02 pin 9. The frequency will be a 26th part of the internal clock frequency (normally 76.923 kHz +/- 600 Hz.), and the duty cycle is 50%.

#### CHECK OF TUNE/ALARM TONE GENERATOR

Press the digits 0 and 1 at same time. The equipment will now be in Quick Service mode and the display will show "SP- ".



### 3.6.5. PERFORMANCE CHECK OF MICROPROCESSOR MODULE 5 cont.

#### Control of Tune Tone

Connect an oscilloscope to emitter of Q01 and press the digits 0-2-0 and ENT. The display will show "SP-02-0". Control that the wave form seen is approx. equal to the one shown below. Press STOP to stop the tone.

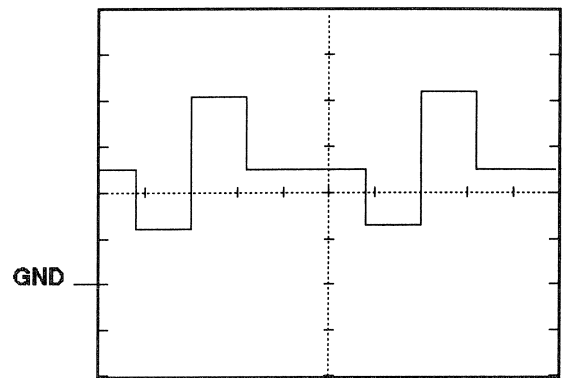

CH1 1V/DIV TB=200uS/div

Tune Tone Test.

#### Control of Alarm Tone

Connect a frequency counter to emitter of Q01 and press the digits 0-2-2 and ENT. The display will show "SP-02-2". Control the frequency to 1300 Hz +/- 1.5%. Press STOP to stop the tone. Then press the digits 0-2-3 and ENT. The display will show "SP-02-3". Control the frequency to 2200 Hz +/- 1.5%. Press STOP to stop the tone. Press TUNE/CLARIF to exit the Quick Service mode.

#### **CHECK OF DISTRESS DRIVER**

Press "2182" (Distress), the RX- and TX-display will show " 2182.0". Connect a voltmeter to collector of Q03 and control the voltage to be 14.8V +/-1.5V. Key-in a new TX-frequency and control that the voltage will go down to approx. 0V.

#### **CHECK OF METER AMPLIFIER**

Connect a test wire between ground and J03 pin 15. Connect a voltmeter between ground and U12 pin 7. Control the voltage to 600 mV +/- 50mV. Connect the test wire between J03 pin 15 and U17 pin 3. Control the voltage on U12 pin 7 to 3.6V +/- 250mV.

#### **CHECK OF SPI DATA BUS**

Press "2182" (Distress), the RX- and TX-display will show " 2182.0". Then press CH-1-ADD and 2-ADD, the distress frequency is now programmed into channel 1 and 2. Then press SC-8-ENT. If the scanning is started, press STOP and delete the channels for scan programme No. 8 until the display shows "CH-no". Press 1-ADD-2-ADD-ENT, channel 1 and channel 2 are now programmed in scan programme No. 8, and the receiver will now scan channel 1 and channel 2 with the same frequency. If the scanner stops at the channel then disconnect the antenna plug.

### 3.6.5. PERFORMANCE CHECK OF MICROPROCESSOR MODULE 5 cont.

#### Check of SPI Data

Connect an oscilloscope channel A to U10 pin 4 and channel B to U10 pin 10. Set TB=50 uS. Control that the two wave forms are the same. The voltage is 5Vpp +/-0.5V.

#### Check of SPI Clock

Connect an oscilloscope channel A to U10 pin 2 and channel B to U10 pin 12. Set TB=50 uS. Control that the two wave forms are the same. The voltage is 5Vpp +/-0.5V. The clock period is 26 uS.

#### Check of Timing Between SPI Data and Clock

Connect an oscilloscope channel A to U10 pin 2 and channel B to U10 pin 4. Set TB=5 uS and control the data set-up time as shown below.

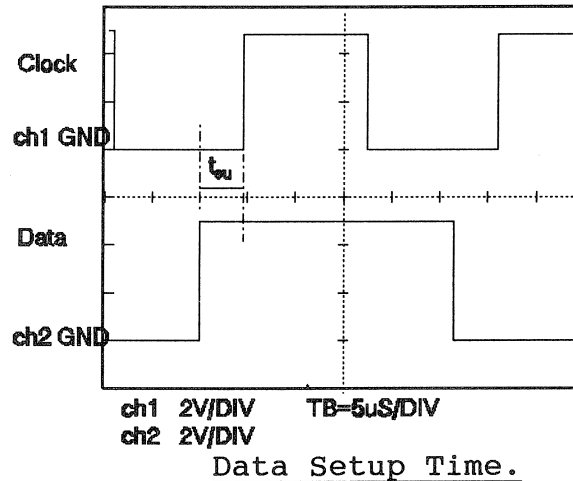

#### Check of SPI Address Select

Connect an oscilloscope channel A to U09 pin 2. Set TB=5uS and control the wave form as shown below. Control the same wave form on U09 pin 3,4,5,6,7,8 and 16.

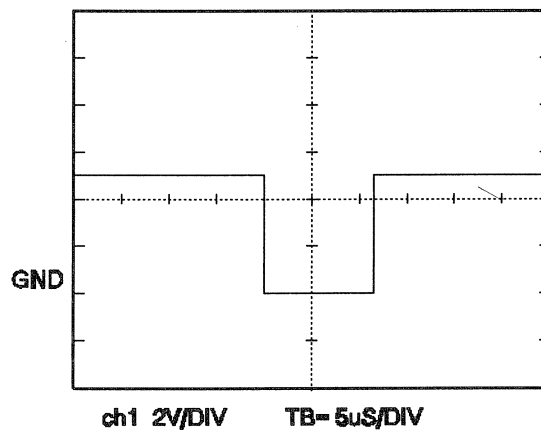

Address Select U09 Pin2,3,4,5,-6,7,8 and pin16.

### 3.6.5. PERFORMANCE CHECK OF MICROPROCESSOR MODULE 5 cont.

Connect an oscilloscope channel A to U09 pin 13. Set TB=500uS and control the wave form as shown below. Control the same wave form on U09 pin 14 and 15.

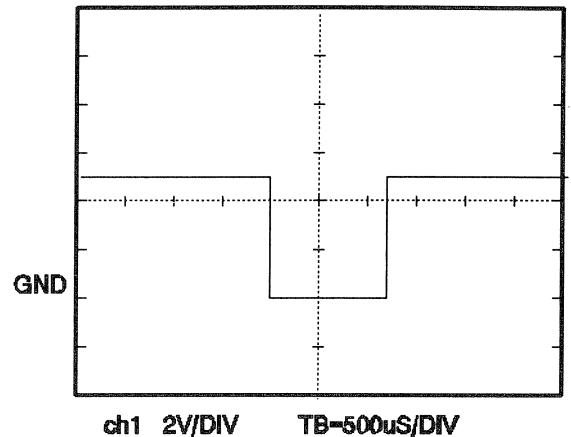

Address Select U09 Pin13, 14 and Pin15

#### CHECK OF SP-BUS TRANSMITTER/RECEIVER

Press the digits 0 and 1 at the same time. The equipment will now be in Quick Service mode and the display will show "SP- ".

Select the service programme SP-00-3 (ref. to chapter 3.10). If the SP-BUS does not work satisfactorily, an "E" will be displayed in the TX-display. Connect an oscilloscope to BNC connector J04 (SP-BUS output). Control that the wave form seen is approx. equal to the one shown below. The 8 data bit and parities bit will change every time the SP-BUS transmitter sends a new byte. Transmit speed is 4800 baud and the time between two bytes is approx. 14 mS.

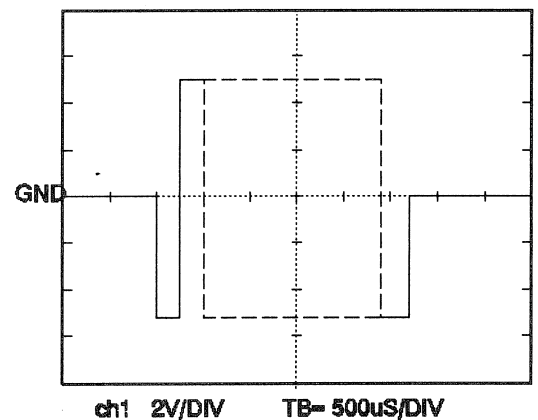

Tx signal on SP-BUS.

#### CHECK OF EEPROM U05

In order to test the Electrical Erasable PROM, the service programme SP-10-0 has to be run. Press the digits 1 and 0 at same time. The equipment will now be in Quick Service mode and the display will show "SP- ". Then press the digit 1-0-0 and finish with ENT. The RX-display will read out "SP-10-0 and the TX-display will start to count from 0 to 512. If the counting stops with 512 and an "A" is shown, the EEPROM is ok. But if the counting is stopped between 0 and 512 and an "E" is shown, there must be a programming error.



## 3.6.8. MODULE PERFORMANCE CHECK OF POWER UNIT

### 3.6.8.1. Check of Voltage Regulators

1. Connect a voltmeter to the outputs of the voltage regulators and check the voltages according to the following table:

U01:	+15V	$\pm 1V$
U02:	-15V	$\pm 1V$
U03:	+15V	$\pm 1V$
U04:	-15V	$\pm 1V$
U06:	+5.3V	$\pm 0.2V$
U07:	+3.5V	$\pm 0.3V$

### 3.6.8.2. Check of RF Amplifier and Filter

1. Connect a 50 ohm resistor to the aerial socket J01-2. Two 100 ohm resistors in parallel soldered on a coax cable connected to the aerial socket are sufficient.
2. Connect an oscilloscope through a 10:1 probe to the 50 ohm resistor.
3. Connect a signal generator to P03-8 with an output power of -9 dBm.
4. Control of the lowpass filter response is carried out by changing the frequency of the signal generator and controlling the reading on the scope. Max. permissible ripple is 2 dB in the frequency range 1.6 MHz to 30 MHz.
5. Tune the signal generator to 22 MHz and read on the scope the voltage to 3.5 Vpp  $\pm 0.5V$ .



## 3.7. ADJUSTMENT PROCEDURE

This chapter contains the adjustment procedure for all adjustable components in the RE2100.

### 3.7.1. ADJUSTMENT PROCEDURE FOR FRONT END AND RECEIVER UNIT

This chapter contains the following sections:

- 3.7.1.1. Adjustment of 70 MHz IF-Filter (Front End and Receiver)
- 3.7.1.2. Adjustment of 70 MHz Transformer (Receiver)
- 3.7.1.3. Adjustment of SSB/AM Filter (Receiver)
- 3.7.1.4. Adjustment of 2nd IF-Gain (Receiver)
- 3.7.1.5. Adjustment of Signal Meter (Receiver)
- 3.7.1.6. Adjustment of Earpiece Level (Receiver)

#### 3.7.1.1. Adjustment of 70 MHz IF-Filter (Front End and Receiver)

The 70 MHz IF-filter is adjusted by tuning the three trimming coils L35-2, L36-2, L37-2, and the two transformers TR04-2, TR01-1.

The components L35-2, L36-2, L37-2 and TR04-2 are all located at the front end unit (module 2), while TR01-1 is located at the receiver unit (module 1).

The adjustment is performed by using the two service programmes SP-04-0 and SP-04-1. These programmes set-up the first local oscillator (LO1) as a test signal and therefore no external signal generator is necessary.

1. Disconnect any input to the aerial socket.
2. Connect a voltmeter to test point TP1-1 for measuring the DC-output voltage from the AGC level detector.
3. Turn the RE2100 on.
4. Select service programme SP-04-0 as described in section 3.10.1. of this manual.
5. Tune the transformer TR01-1 (Receiver Module) and the trimming coil L37-2 (Front End Module) to maximum meter deflection.
6. Select service programme SP-04-1 (press <STOP> to terminate the first service programme).
7. Tune the transformer TR04-2 and the trimming coils L35-2 and L36-2 to maximum meter deflection.
8. Select service programme SP-04-0.
9. Turn off the AGC and adjust the manual RF GAIN until the DC-output voltage from the AGC level detector is about 5 volt.
10. Finetune all five components by repeating point 5-7. Remember to turn off the AGC in point 6 after selecting the service programme SP-04-1.

### 3.7.1. ADJUSTMENT PROCEDURE FOR FRONT END AND RECEIVER UNIT cont.:

**NOTE!** If the DC-output voltage from the AGC level detector is increased to a level above 9 Volt, it is necessary to readjust the manual RF-gain until the voltage level is about 5 Volt.

11. Press <TUNE> to leave the service programme mode.

#### 3.7.1.2. Adjustment of 70 MHz Transformer (Receiver)

The position number of the 70 MHz transformer is TR01-1 and it is located at the receiver unit (module 1). The adjustment is performed by tuning TR01-1 until the DC-output voltage from the AGC level detector is maximum. The tuning is performed by using the service programme SP-04-0. This programme sets-up the first local oscillator (LO1) as a test signal and therefore no external signal generator is necessary.

1. Execute points 1-4 in section 3.7.1.1.
2. Tune the 70 MHz transformer TR01-1 to maximum meter deflection.
3. Turn off the AGC and adjust the manual RF GAIN until the DC-output voltage from the AGC level detector is about 5 Volt.
4. Finetune TR01-1.
5. Press <TUNE> to leave the service programme mode.

#### 3.7.1.3. Adjustment of SSB/AM-Filter (Receiver)

The SSB/AM-filter is adjusted by tuning the trimming capacitor C181 until the DC-output voltage from the AGC level detector is maximum. The trimming capacitor C18-1 is located at the receiver unit (module 1). The adjustment is performed by using the service programme SP-042. This programme sets-up the first local oscillator (LO1) as a test signal and therefore no external signal generator is necessary.

1. Execute points 1-3 in section 3.7.1.1.
2. Select service programme SP-04-2.
3. Adjust the manual RF-gain until the DC-output voltage from the AGC level detector is about 5V.
4. Tune the trimming capacitor C18-1 to maximum meter deflection.
5. Press <TUNE> to leave the service programme mode.

#### 3.7.1.4. Adjustment of 2nd IF-Gain (Receiver)

To meet the gain variations from one transistor to another, the 2nd IF-amplifier has been constructed with a reserve of power gain. This implies that the 2nd IF-gain may be very large, which may cause unstable conditions because of unwanted feedback.

It is therefore necessary to adjust the unregulated gain of the 2nd IF-amplifier, which must be done in accordance with the procedure given below.

The 2nd IF-gain is adjusted by trimming the resistor R203-1, which is located at the receiver unit (module 1).

The adjustment is performed by using a signal generator and an AC voltmeter.



### 3.7.1. ADJUSTMENT PROCEDURE FOR FRONT END AND RECEIVER UNIT cont.:

1. Connect the signal generator to the aerial socket at the front end unit.
2. Connect the AC voltmeter to earpiece output at testpoint TP2-1.
3. Turn the RE2100 on.  
**NOTE!** The RE2100 must be on for at least five minutes before proceeding.
4. Select the setting of the signal generator and the RE2100 according to point 5.

5.

Signal Generator			RE2100	
Frequency	Level	Mode	Frequency	Mode
1991 kHz	33dB/uV	CW	1990 kHz	J3E

6. Measure the AC voltage at the earpiece output.
7. Change the generator output level to 0dB/uV.
8. Adjust the resistor R203-1 until the AC voltage at earpiece output is decreased by 4 dB relative to the level measured in point 6.

#### 3.7.1.5. Adjustment of Signal Meter (Receiver)

The signal meter is adjusted by trimming the resistor R76-1, which is located at the receiver unit (module 1).

1. Disconnect any input to the aerial socket.
2. Turn the RE2100 on and make sure that J3E-mode (SSB) is selected and that the AGC is operative.
3. Adjust R76-1 until the first LED-bar in the display is just about to light.

#### 3.7.1.6. Adjustment of Earpiece Level (Receiver)

The earpiece level is adjusted by trimming the resistor R52-1, which is located at the receiver unit (module 1).

The adjustment is performed by using the service programme SP-04-3. This programme sets-up the first local oscillator (LO1) as a test signal and therefore no external signal generator is necessary.

1. Disconnect any input to the aerial socket.
2. Connect a voltmeter to earpiece output at testpoint TP2-1 for measuring the AC-voltage.
3. Turn the RE2100 on.
4. Select service programme SP-04-3.
5. Adjust R52-1 until the earpiece level is  $0.8 V_{RMS} \pm 0.1 V_{RMS}$ .
6. Press <TUNE> to leave the service programme mode.

## 3.7.2. ADJUSTMENT PROCEDURE FOR SYNTHESIZER UNIT

This chapter contains the following sections:

- 3.7.2.1. Adjustment of TCXO
- 3.7.2.2. Adjustment of API Voltage in PLL1
- 3.7.2.3. Adjustment of the VCO Circuits in PLL1
- 3.7.2.4. Adjustment of the VCO Circuits in PLL2

### 3.7.2.1. Adjustment of TCXO

The Temperature Compensated X-tal Oscillator (TCXO) delivers the reference frequency, which is common for both PLL1 and PLL2.

The adjustment is performed by measuring the TCXO frequency at the output of the TCXO buffer at testpoint TP4-3 (collector of transistor Q26-3).

1. Turn the RE2100 on.  
**NOTE!** The RE2100 must be on for at least 15 minutes before the adjustment is carried out.
2. Connect the counter to TP4-3 through passive probe.
3. Adjust the TCXO, until the frequency at TP4-3 is 10.731520 MHz  $\pm$ 1 Hz.

### 3.7.2.2. Adjustment of API Voltage in PLL1

The API voltage is adjusted by trimming the resistor R88-3, which is located at the Synthesizer Unit (module 3).

The adjustment is performed by using the service programme SP-04-4. This programme sets up a special receiver mode, where the API sideband from the L01 is passed through the SSB crystal filter and the 2nd IF-amplifier. The level of the API sideband can then be measured as a DC voltage at the level detector output at testpoint TP1-1.

1. Turn the RE2100 on.
2. Connect the DC voltmeter to TP1-1 located on the Receiver Unit (module 1).
3. Select service programme SP-04-4 as described in this manual, section 3.10.1.
4. Adjust potentiometer R88-3 for minimum meter deflection.

### 3.7.2.3. Adjustment of the VCO Circuits in PLL1

The PLL1 consists of four independent Voltage Controlled Oscillators, which each covers about a quarter of the whole frequency band of 30 MHz.

The VCO circuits are adjusted by four individual coils. The adjustment is performed at the upper frequency in each of the four VCO bands and the coils are adjusted until the output voltage from the active loop filter is -11.0 Volt.

1. Turn the RE2100 on.
2. Connect the voltmeter to TP1-3.

### 3.7.2. ADJUSTMENT PROCEDURE FOR SYNTHESIZER UNIT cont.:

3. Key-in the RX-frequencies and adjust VCO coils according to table 4 until voltage on TP1-3 is -11.0 Volt.

4.

RX-frequency	Adjustment of
7499.0	TR03
14999.0	TR04
22499.0	TR05
29999.0	TR06

5. Key-in the RX-frequencies according to table 6 and check the voltage on TP1-3 to be -3 Volt + 1.0 Volt.

**NOTE!** No adjustments of VCO coils shall be made.

6. RX-frequency

100.0

7500.0

15000.0

22500.0

#### 3.7.2.4. Adjustment of the VCO Circuits in PLL2

The PLL2 consists of two independent Voltage Controlled Oscillators, which are used in USB and LSB mode respectively.

The VCO circuits are adjusted by two individual coils, which are adjusted until the output voltage from the active loop filter is -6.5 Volt.

1. Turn the RE2100 on.
2. Connect the voltmeter to TP5-3.
3. Select J3E mode and adjust TR08 until the voltage on TP5-3 is -6.5 Volt.
4. Select LSB mode and adjust TR07 until the voltage on TP5-3 is -6.5 Volt.

### 3.7.3. ADJUSTMENT PROCEDURE FOR EXCITER UNIT

This chapter contains the following sections:

- 3.7.3.1. Adjustment of Compressor and AF Limiter
- 3.7.3.2. Adjustment of Carrier Limit Amplifier
- 3.7.3.3. Adjustment of Modulator
- 3.7.3.4. Adjustment of RF Limiter
- 3.7.3.5. Adjustment of Carrier Insertion
- 3.7.3.6. Adjustment of Step Attenuator
- 3.7.3.7. Adjustment of 70 MHz IF

For best stability, all coils and transformers are adjusted with the cores in the lower resonant position.

For each circuit to be adjusted, it is a condition that all the previous circuits are adjusted to obtain the best possible adjustment.

In the adjustment procedure for the Exciter Unit, four service programmes are used, SP-05-0, 1, 2, and 3. How to select the service programmes is described in section 3.10.1.

#### 3.7.3.1. Adjustment of Compressor and AF Limiter

The compression level is adjusted by R35-4 and the cutting symmetry is determined by R57-4.

1. Connect the scope probe to the emitter of Q04-4 (TP1-4).
2. Select service programme SP-05-0.
3. A combined square wave signal (tune tones) is seen on the scope.
4. Turn R35-4 clockwise until the signal reaches a limiting level.
5. Adjust R57-4 to obtain a symmetrical cutting of the signal. That is, when both top and bottom of the signal reach the limiting level simultaneously when the signal is increased by means of R35-4.
6. Turn R35-4 fully clockwise.
7. Adjust the scope until there is full deflection (8 div.) on the scope.
8. Adjust R35-4 until the deflection seen on the scope is 7 div. peak-peak. The signal is now under the limiting level.
9. If this adjustment is the only one executed after repair, please execute 3.7.3.4. Adjustment of RF Limiter.

#### 3.7.3.2. Adjustment of Carrier Limit Amplifier

1. Connect scope probe to the connection between R93-4 and C75-4 (TP2-4).
2. Select service programme SP-05-0.
3. Press handset key.

### 3.7.3. ADJUSTMENT PROCEDURE FOR EXCITER UNIT cont.:

4. Adjust L05-4 to maximum signal.
5. Release handset key.

#### 3.7.3.3. Adjustment of Modulator

1. Connect scope probe to the connection between C66-4 and C67-4 (TP3-4).
2. Select service programme SP-05-0.
3. Press handset key.
4. Adjust TR01-4 to maximum signal.
5. Release handset key.
6. Select service programme SP-05-1.
7. Select H3E on the keyboard.
8. Press handset key.
9. Adjust R190-4 to minimum signal (noise) on the scope.
10. Release handset key.
11. If this adjustment is the only one executed after repair, please execute 3.7.3.4. Adjustment of RF Limiter.

#### 3.7.3.4. Adjustment of RF Limiter

1. Connect scope probe to emitter of Q19-4 (TP4-4).
2. Select service programme SP-05-0.
3. Press handset key.
4. Adjust L07-4, L08-4, and TR02-4 to maximum signal.
5. Turn R87-4 fully clockwise. The signal is cut.
6. Adjust scope until there is full deflection on the scope (8 div.).
7. Adjust R87-4 until the deflection seen on the scope is 7.2 div. The signal is not cut.
8. Release handset key.

#### 3.7.3.5. Adjustment of Carrier Insertion

1. Connect scope probe to emitter of Q19-4 (TP4-4).
2. Select service programme SP-05-0.
3. Press handset key.

### 3.7.3. ADJUSTMENT PROCEDURE FOR EXCITER UNIT cont.:

4. Adjust scope until there is full deflection (8 div.) on the screen.
5. Release handset key and press <ENT> on the keyboard.
6. Select service programme SP-05-1.
7. Select H3E mode on the keyboard.
8. Press handset key.
9. Adjust R92-4 until the deflection on the screen of the carrier signal is 4.4 div.
10. Release handset key.

#### 3.7.3.6. Adjustment of Step Attenuator

1. Connect scope probe to emitter of Q18-4 (TP5-4).
2. Select service programme SP-05-0.
3. Press handset key.
4. Adjust L09-4 to maximum signal.
5. Release handset key and press <ENT> on the keyboard.
6. Select service programme SP-05-2.
7. Connect another scope probe to R143-4 (TP6-4). This signal is used to trig the scope. The scope must be triggered by the negative transition.
8. On the scope is now seen a staircase waveform. When adjusting R159-4 it can be seen that one of the steps changes amplitude.

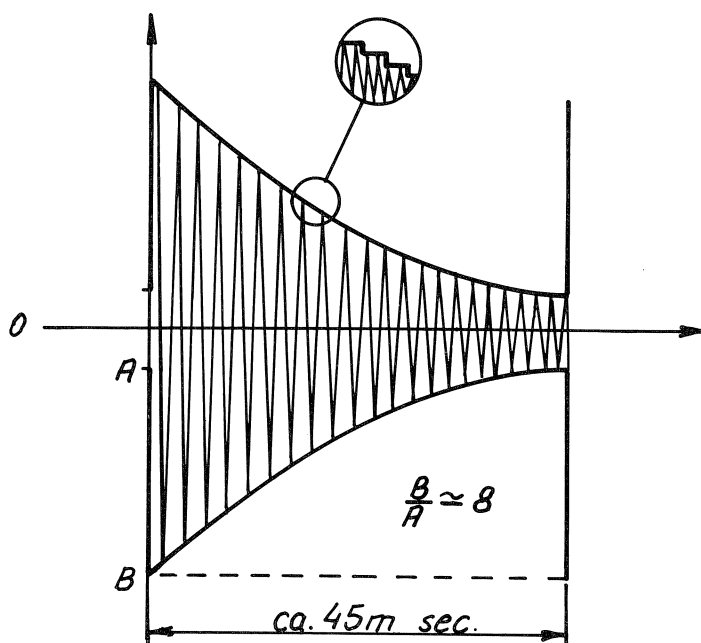

### 3.7.3. ADJUSTMENT PROCEDURE FOR EXCITER UNIT cont.:

9. Adjust R159-4 until the step, which changes amplitude, is approximately equal to the neighbour steps.
10. Press <ENT> on the keyboard.
11. To adjust the RF output power level from the Exciter Unit to the Power Unit (8), it is a condition that both the 70 MHz IF filter and the Power Unit are correctly adjusted. If not, perform section 3.7.3.7. and 3.7.4.2.
12. Connect a 50 ohm resistor to the aerial socket. Two 100 ohm resistors in parallel soldered on a coax cable connected to the aerial socket are sufficient.
13. Connect an oscilloscope through a 10:1 probe to the 50 ohm resistor.
14. Select service programme SP-05-0.
15. Press handset key.
16. Adjust R120-4 until the signal on the scope is 3.5 Vpp. If a milliwattmeter is connected to the aerial socket J01-2 it should read 12 dBm in 50 ohm.
17. Release handset key.

#### 3.7.3.7. Adjustment of 70 MHz IF

When using the two service programmes SP-05-1 and SP-05-3, the 70 MHz IF filter can be adjusted.

1. Connect scope probe to the output of the Power Unit at P04-8 (TP1-8).
2. Select service programme SP-05-3.
3. Select H3E on keyboard and press handset key.
4. Adjust L10-6, L11-4 and L12-4 several times to obtain maximum signal on the scope.
5. Release handset key and press <ENT> on the keyboard.
6. Select service programme SP-05-1.
7. Select H3E mode on keyboard and press handset key.
8. Readjust only L10-4 to maximum signal.
9. Release handset key.

### 3.7.4. ADJUSTMENT PROCEDURE FOR POWER UNIT.

This chapter contains the adjustments for the 5V regulator and the RF power output level to the transmitter.

#### 3.7.4.1. Adjustment of +5V

The +5V output voltage must have a value between 5.1V and 5.5V to ensure stability in the Synthesizer Unit. Normally the resistor R33-8 is removed at the factory. If the regulator U06-8 has been changed for repair then check the output voltage.

Connect a voltmeter to R16-8 (TP2-8) and measure the output voltage with R33-8 removed, and one of the following three situations occur:

	Measured Value		Adjusted Value
a:	$V_o < 5.15V$	=> R32-8 removes	=> $5.10 < V_o < 5.30V$
b:	$5.15V < V_o < 5.40V$	=> nothing	=> $5.15V < V_o < 5.40V$
c:	$V_o > 5.40V$	=> R33-8 replaces	=> $5.25 < V_o < 5.45V$

#### 3.7.4.2. Adjustment of RF Output Level

1. Connect a 50 ohm resistor to the aerial socket J01-2. Two 100 ohm resistors in parallel soldered on a coax cable connected to the aerial socket are sufficient.
2. Connect an oscilloscope through a 10:1 probe to the 50 ohm resistor.
3. Connect a signal generator to P03-8. Tune the signal generator to deliver -9 dBm output power at 22 MHz.
5. Select service programme SP-05-0 to start-up the voltage regulators U01-8 and U02-8.
6. Adjust R30-8 until the output voltage seen on the scope is 3.25 Vpp.
7. If a milliwattmeter is connected to the aerial socket J01-2 it should read 14 dBm. RF gain at 22 MHz is 23 dB.



## 3.8. NECESSARY ADJUSTMENT AND CHECK AFTER REPAIR

### GENERAL

After repair of the RE2100 it may be necessary to do some adjustments and checks.

The extent of these adjustments and checks can only be decided by the person, who has done the repair, and this manual section must only be looked upon as a guide.

Any repair must, as mentioned previously, be followed by a function check after reinstallation of the RE2100.

### RECEIVER UNIT (MODULE 1)

#### After a Change of the Module

Execute 3.7.1.5. Adjustment of Signal Meter, and 3.5.2. Performance Check of Receiver.

#### Repair in 2nd Mixer and the Corresponding Input Matching Circuit

Execute 3.7.1.2. Adjustment of 70 MHz Transformer, and 3.5.2.1. Performance Check of Receiver Sensitivity.

#### Repair in L02 Buffer

Execute 3.6.1.2. Check of L02 and Reinjection Signals, and 3.5.2.1. Performance Check of Receiver Sensitivity.

#### Repair in SSB/AM Crystal Filters and the Corresponding Input/Output Matching Network

Execute 3.7.1.3. Adjustment of SSB/AM Filter.

Execute 3.6.1.3. Check of Crystal Filters, and 3.5.2.1. Performance Check of Receiver Sensitivity.

#### Repair in 2nd IF Amplifier and AGC Circuit

Execute 3.7.1.4. Adjustment of 2nd IF Gain, and 3.7.1.5. Adjustment of Signal Meter.

Execute 3.5.2.5. Performance Check of Receiver AGC, and 3.5.2.1. Performance Check of Receiver Sensitivity.

#### Repair in Detector

Execute 3.5.2.1. Performance Check of Receiver Sensitivity, and 3.5.2.2. Performance Check of Receiver Distortion.

#### Repair in Audio Frequency Filter

Execute 3.5.2.3. Performance Check of Receiver Audio Passband, and 3.5.2.1. Performance Check of Receiver Distortion.

#### Repair in Earpiece Amplifier

Execute 3.7.1.6. Performance Check of Earpiece Level, and 3.5.2.2. Performance Check of Receiver Distortion.

#### Repair in Squelch Circuit

Execute 3.5.2.6. Performance Check of Receiver Squelch.

### 3.8. NECESSARY ADJUSTMENT AND CHECK AFTER REPAIR cont.:

#### FRONT END UNIT (MODULE 2)

##### After a Change of the Module

Execute 3.5.2.1. Performance Check of Receiver Sensitivity, and 3.5.2.3. Performance Check of Receiver Audio Passband.

##### Repair in Input Protection Circuit and Pre-Filters

Execute 3.5.2.1. Performance Check of Receiver Sensitivity, and 3.5.2.2. Performance Check of Receiver Distortion.

##### Repair in 1st Mixer and 70 MHz IF Filter

Execute 3.7.1.1. Adjustment of 70 MHz IF Filter.

Execute 3.5.2.1. Performance Check of Receiver Sensitivity, and 3.5.2.3. Performance Check of Receiver Audio Passband.

##### Repair in L01 Buffer

Execute 3.5.2.1. Performance Check of Receiver Sensitivity.

#### SYNTHESIZER UNIT (MODULE 3)

##### After a Change of the Module

Execute 3.5.2.1. Performance Check of Receiver Sensitivity, and 3.5.2.4. Performance Check of Receiver Clarifier and Frequency.

Execute 3.5.3.2. Performance Check of Exciter Frequencies and Classes of Emission.

##### Repair in the TCXO and Buffer

Execute 3.7.2.1. Adjustment of TCXO.

##### Repair in Phase Detector, Current Mirror and API Circuit (PLL1)

Execute 3.7.2.2. Adjustment of API Voltage in PLL1, and 3.7.2.3. Adjustment of the VCO Circuits in PLL1.

Execute 3.5.2.1. Performance Check of Receiver Sensitivity, and 3.5.2.4. Performance Check of Receiver Clarifier and Frequency.

##### Repair in the PLL1

Execute 3.7.2.3. Adjustment of the VCO Circuit in PLL1.

Execute 3.5.2.1. Performance Check of Receiver Sensitivity, 3.5.2.4. Performance Check of Receiver Clarifier and Frequency, and 3.5.3.2. Performance Check of Exciter Frequencies and Classes of Emission.

##### Repair in the PLL2

Execute 3.7.2.4. Adjustment of the VCO Circuits in PLL2.

Execute 3.5.2.1. Performance Check of Receiver Sensitivity, 3.5.2.4. Performance Check of Receiver Clarifier and Frequency, and 3.5.3.2. Performance Check of Exciter Frequencies and Classes of Emission.

#### EXCITER UNIT (MODULE 4)

##### After a Change of the Module

Execute 3.5.3. PERFORMANCE CHECK OF EXCITER.

##### Repair in AF Selector, Compressor, and AF Limiter

Execute 3.7.3.1. Adjustment of Compressor and AF Limiter.

Execute 3.6.4.5. Check of RF Limiter and Carrier Insertion.

### 3.8. NECESSARY ADJUSTMENT AND CHECK AFTER REPAIR cont.:

#### Repair in Carrier Limiter Amplifier

Execute 3.7.3.2. Adjustment of Carrier Limiter Amplifier, and 3.7.3.4. Adjustment of RF Limiter, and 3.7.3.5. Adjustment of Carrier Insertion.

#### Repair in Modulator and Modulation Level Amplifier

Execute 3.7.3.3. Adjustment of Modulator, and 3.7.3.4. Adjustment of RF Limiter.

Execute 3.6.4.5. Check of RF Limiter and Carrier Insertion.

#### Repair in RF Limiter, Carrier Insertion and SSB Filter

Execute 3.7.3.4. Adjustment of RF Limiter, and 3.7.3.5. Adjustment of Carrier Insertion.

#### Repair in Step Attenuator

Execute 3.7.3.6. Adjustment of Step Attenuator.

#### Repair in 70 MHz IF

Execute 3.7.3.6. Adjustmnet of 70 MHz IF, and 3.7.3.6. Adjustment of Step Attenuator, section 3.7.3.6. points 12. - 17.

### PROCESSOR UNIT (MODULE 5)

#### After a Change or Repair of the Module

Execute 3.5.1.1. and 3.5.1.2. Performance Check of Display and Keyboard.

Execute 3.5.2.4. Performance Check of Receiver Clarifier and Frequency, and 3.5.3.2. Performance Check of Exciter Frequencies and Classes of Emission.

### KEYBOARD UNIT (MODULE 6)

#### After a Change or Repair of the Module

Execute 3.5.1.2. Performance Check of Keyboard.

### DISPLAY UNIT (MODULE 7)

#### After a Change or Repair of the Module

Execute 3.5.1.1. Performance Check of Display.

### POWER UNIT (MODULE 8)

#### After a Change of the Module

Execute 3.5.3. PERFORMANCE CHECK OF EXCITER.

#### Repair of +5V Regulator

Execute 3.7.4.1. Adjustment of +5V.

#### Repair of the Other Voltage Regulators

Execute 3.6.8.1. Check of Voltage Regulators.

#### Repair in RF Amplifier and Filter

Execute 3.7.4.2. Adjustment of RF Output Level, and 3.6.8.2. Check of RF Amplifier and Filter.

### 3.9. FUNCTION CHECK

The function check is a simple test to ensure that the RE2100 is working properly after installation.

The function check must always be carried out after a repair of the RE2100. Any repair of the RE2100 must be followed by a performance check, and after reinstallation a function check must be carried out in order to make sure that the fault has been repaired and that the RE2100 is working correctly together with the installed transmitter T2130 and aerial coupler AT2110.

1. Turn on the VOL-OFF switch and control that noise is heard in the loudspeaker and the display is alight.
2. Press the keyboard buttons 0 and 1 simultaneously.
3. Select the test programme SP-00-2.
4. Control that all the leds in the display are activated, the mode indicating light emitting diodes are toggled, and the three light emitting diodes, indicating the power level, are alight.
5. Press the RF-GAIN control fully counter clockwise and control that all the light emitting diodes in the signal meter are alight.
7. Key-in a known broadcast station in the frequency range 100 - 384 kHz.
8. Notice that the detected AF signal is heard from the loudspeaker and from the handset earpiece without distortion.
9. Toggle the keyboard button MODE, until J3E mode is chosen.
10. Notice that no beat note is heard in the loudspeaker.
11. Press the keyboard FREQ arrow buttons to toggle the 100 Hz decimal up and down.
12. Control that the beat note heard in the loudspeaker changes with the 100 Hz steps.
13. Key-in a known broadcast station in the frequency range 385 - 1600 kHz.
14. Notice that the detected AF signal is heard from the loudspeaker without distortion.
15. Key-in a known coastal station frequency in the frequency range 1600 - 3990 kHz.
16. When listening to the coastal station, activate the clarifier and control that it is working properly.
17. Key-in one ITU channel in each of the maritime bands from 4.0 - 25.0 MHz and control that the receiver is working properly.

### 3.9. FUNCTION CHECK cont.:

18. Activate a scan programme or key-in a scan programme, and control that the scan function is working correctly.
19. Active the keyboard AGC and SQ button and control that the leds marked AGC and SQ can be toggled.
20. When activating the SQ function, control that the noise from the loudspeaker disappears.
21. Select the lowest transmitting frequency and press first TX, and then TUNE. When the tune lamp extinguishes, press the handset key and whistle into the microphone. While whisteling, release the handset key.
22. Press the keyboard buttons 0 and 1 simultaneously.
23. Select the test programme SP-20-0.
24. Press the keyboard button ENT.
25. The TX display will now show the battery voltage when transmitting. This voltage must be above 22V DC.
26. Select the test programme SP-22-2.
27. Press the keyboard button ENT.
28. The TX display shows the latest measured  $V_{\text{forward}}$ . This voltage must be above 9V DC.
29. Select the test programme SP-23-0.
30. Press the keyboard button ENT.
31. The TX display shows the SWR, which must be below 2.
32. Select the test programme SP-26-1.
33. Press the keyboard button ENT.
34. The TX display shows the drive setting, which must be above 12.
35. Press the keyboard button TUNE.
36. Check that it is possible to tune and to transmit in all maritime bands.
37. Press the keyboard button TX, and then the button DUMMY LOAD.
38. Activate the handset key.
39. When the tune lamp extinguishes, press the keyboard buttons SEND ALARM and TEST ALARM simultaneously.
40. The transmitter sends the alarm tone signal to the dummy load, which can be seen on the AE-current meter.
41. The alarm tones will be heard in the handset earpiece.
42. Press the keyboard button ENT.
43. The transmitter stops transmitting.
44. As a final test, make a call to a coast station.

## 3.10. SELECTION AND DESCRIPTION OF THE SERVICE PROGRAMMES

### 3.10.1. How to Select a Service Programme

In order to help the operator, and the service engineer during installation or repair, the RE2100 has some built-in service programmes.

The RE2100 has a service mode, which is activated by pressing the keyboard buttons 1 and 0 simultaneously. The display of the RE2100 will now show 'SP-'.

The various service programmes can now be selected by keying-in a three digit number. The display of the RE2100 will then show 'SP-XX-X'.

A new service programme may be chosen after the keyboard button ENT has been pressed once. The display shows 'SP-' again, and a new three digit number can be keyed-in.

In order to return to normal operation mode, press the keyboard button TUNE/CLARIF.

### 3.10.2. Description of Service Programmes

#### **SP-00-X TEST OF PROCESSOR, KEYBOARD AND DISPLAY MODULE**

When 00 has been keyed-in, the RX display shows 'SP-00-', and the programmes 0 to 3 and 8 may be selected.

#### **SP-00-0 READ OUT OF SOFTWARE VERSION NUMBER**

In the TX display a 4 digit number will be read out, possibly followed by a letter. The number indicates S. P. Radio's internal software number and the letter indicates the software release.

Ex. 1085E => C-number C1085 and rel. E.

#### **SP-00-1 READS OUT WHICH ITU FREQUENCY TABLE IS USED**

When P-91 is read out, an earlier ITU table is used. When A-91 is read out, the ITU table in force from 1st June 1991 is used.

When keying-in the digit 0 or 1, the read out will be changed from A-91 to P-91 or P-91 to A-91 respectively.

#### **SP-00-2 STARTS TEST OF THE DISPLAY**

This test programme is used in the performance check, section 3.5.1.1.

When pressing <ENT> during the test, the test procedure stops. When pressing <ENT> again, the programme steps forward. When pressing <0>, the programme continues again automatically.

#### **SP-00-3 TEST OF SP-BUS**

This test programme is used in the performance check, section 3.5.1.1.

The processor sends a byte to itself via the serial SCI communication port. Each time an error is received, the display reads-out an 'E'. If there is no error, a bar '-' runs through the TX display.

### 3.10. SELECTION AND DESCRIPTION OF THE SERVICE PROGRAMMES cont.:

#### **SP-00-8 TEST OF KEYBOARD**

This test programme is used to test all the keyboard buttons. When the programme is selected, press the keyboard from the top of the right corner down to the left corner. E.g. 1,2,3,4,5,6,-FREQ DOWN,.....0,,ENT. When the buttons are pressed, the display reads-out the number of the button (ref. chapter 5.6. KEYBOARD UNIT). If the button does not work, the display reads-out the number of the button with a letter "E", when the next button is pressed.

#### **SP-04-X TEST OF FRONTEND, RECEIVER AND SYNTHESIZER MODULE**

When 04 has been keyed in, the RX display shows 'SP-04-', and the programmes 0 to 7 may be selected.

#### **SP-04-0 ADJUSTMENT OF 70 MHz RECEIVER FILTER**

This test programme is used in the adjustment procedure, sections 3.7.1.1. and 3.7.1.2, where it sets up the synthesizer, frontend, and receiver module for adjustment of the 70 MHz intermediate filter.

#### **SP-04-1 ADJUSTMENT OF 70 MHz RECEIVER FILTER**

This test programme is used in the adjustment procedure, section 3.7.1.1., where it sets up the synthesizer, frontend, and receiver module for adjustment of the 70 MHz intermediate filter.

#### **SP-04-2 ADJUSTMENT OF SSB/AM RECEIVER FILTER**

This test programme is used in the adjustment procedure, section 3.7.1.3., where it sets up the synthesizer, frontend, and receiver module for adjustment of the 10.7 MHz SSB/AM intermediate filter.

#### **SP-04-3 ADJUSTMENT OF EARPIECE LEVEL**

This test programme is used in the adjustment procedure, section 3.7.1.6., where it sets up the synthesizer, frontend, and receiver module for adjustment of the earpiece level.

#### **SP-04-4 ADJUSTMENT OF API VOLTAGE**

This test programme is used in the adjustment procedure, section 3.7.2.2., where it sets up the synthesizer, frontend, and receiver module for adjustment of the API sideband level.

#### **SP-04-5 TEST OF LO1 AND LO2 SIGNALS TO EXCITER**

This test programme is used in the module performance check, section 3.6.1.5., where it sets up the synthesizer, exciter, and frontend module, in order to control that the local oscillator signals are present at the exciter module.

### 3.10. SELECTION AND DESCRIPTION OF THE SERVICE PROGRAMMES cont.:

#### SP-04-6 TEST OF ATTACK AND DECAY TIME FOR AGC IN SSB MODE

This test programme is used in the module performance check, section 3.6.1.5., and performance check, section 3.5.2.5., where it sets up the synthesizer, frontend, and receiver module, in order to control that the SSB AGC attack and decay times are inside the limits.

#### SP-04-7 TEST OF ATTACK AND DECAY TIME FOR AGC IN AM MODE

This test programme is used in the module performance check, section 3.6.1.5., and performance check, section 3.5.2.5., where it sets up the synthesizer, frontend, and receiver module, in order to control that the AM AGC attack and decay time are inside the limits.

#### SP-05-X TEST OF EXCITER AND POWER MODULE

When the RE2100 is not connected with a transmitter T2130, it is not possible to activate the exciter module. It is therefore necessary to activate a test programme to get the exciter to work.

When 05 has been keyed-in, the RX display shows 'SP-05-', and the test programmes 0 to 6 may be selected.

#### SP-05-0 EXCITER ACTIVATED IN TUNE MODE

The exciter output frequency is set to  $f_{TX} = 22000.0$  kHz, the tune tones can be activated by the handset key, and the transmit mode is J3E. Exciter step attenuator is set to max. output power.

#### SP-05-1 EXCITER ACTIVATED IN TELEPHONY MODE

The exciter output frequency is set to  $f_{TX} = 22000.0$  kHz, LF signal generator can be connected to testbox terminal AF to Telex, and the handset key is valid. Mode shift is possible, but the modulation is turned off in H3E mode. Exciter step attenuator is set to max. output power.

#### SP-05-2 TEST OF EXCITER STEP ATTENUATOR

The exciter output frequency is set to  $f_{TX} = 22000.0$  kHz, and the step attenuator is incremented with 1 step every 700  $\mu$ S, until step 63 is reached. Then the attenuator is reset to step 0.

The test programme is used in the performance check, section 3.5.3.4., module performance check, section 3.6.4.6., and module adjustment, section 3.7.3.6.

#### SP-05-3 TEST OF EXCITER 70 MHz FILTER

This test programme is used in the module performance check, section 3.6.4.7., and in module adjustment, section 3.7.3.7., where it sets up the synthesizer and exciter to control the 70 MHz intermediate filter.

#### SP-05-4 EXCITER ACTIVATED IN TELEPHONY MODE

The exciter is activated as in test programme SP-05-1, but the exciter output frequency is changed to 28000.0 kHz.



### 3.10. SELECTION AND DESCRIPTION OF THE SERVICE PROGRAMMES cont.:

#### **SP-05-5 EXCITER ACTIVATED IN TELEPHONY MODE**

The exciter is activated as in test programme SP-05-1, but the exciter output frequency is changed to 14900.0 kHz.

#### **SP-05-6 EXCITER ACTIVATED IN TELEPHONY MODE**

The exciter is activated as in test programme SP-05-1, but the exciter output frequency is changed to 1600.0 kHz and modulation is possible in H3E mode



## CONTENTS

- 4. MECHANICAL DISASSEMBLING AND MODULE LOCATION
- 4.1. ADJUSTMENTS AND LOCATION



4.1. MECHANICAL DISASSEMBLING AND MODULE LOCATION

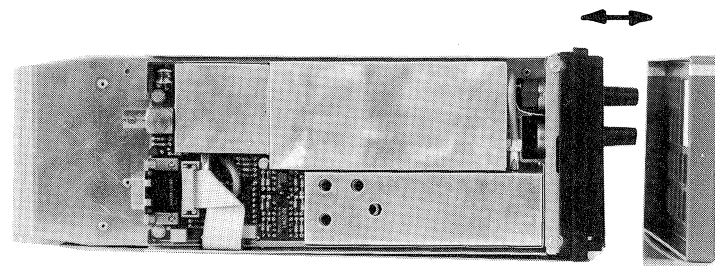
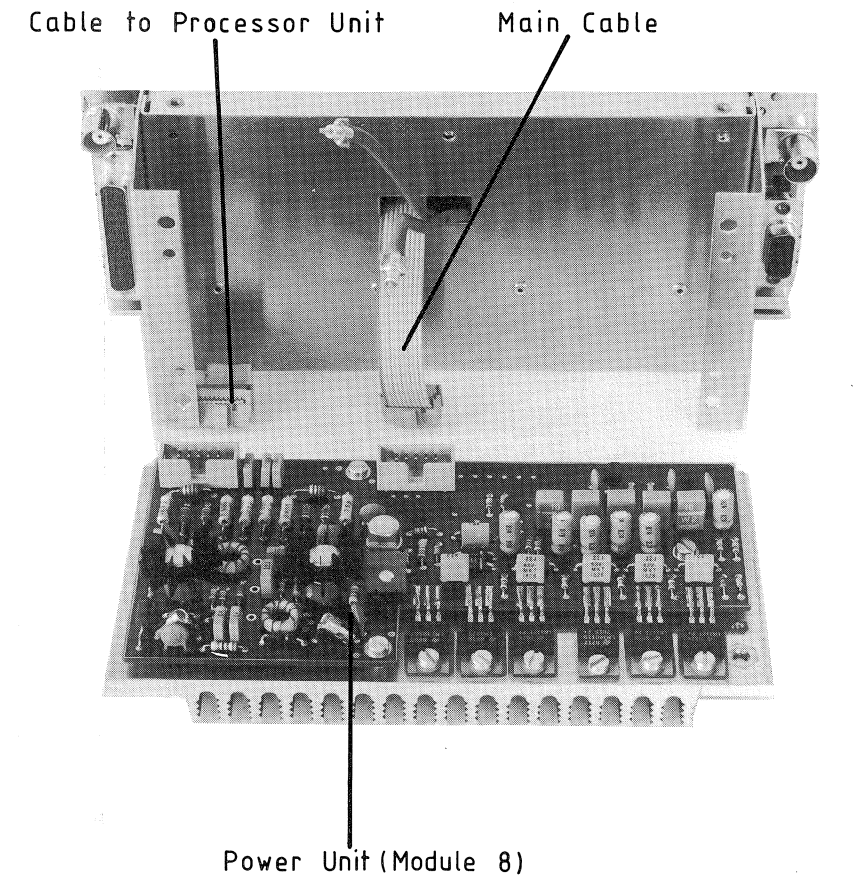
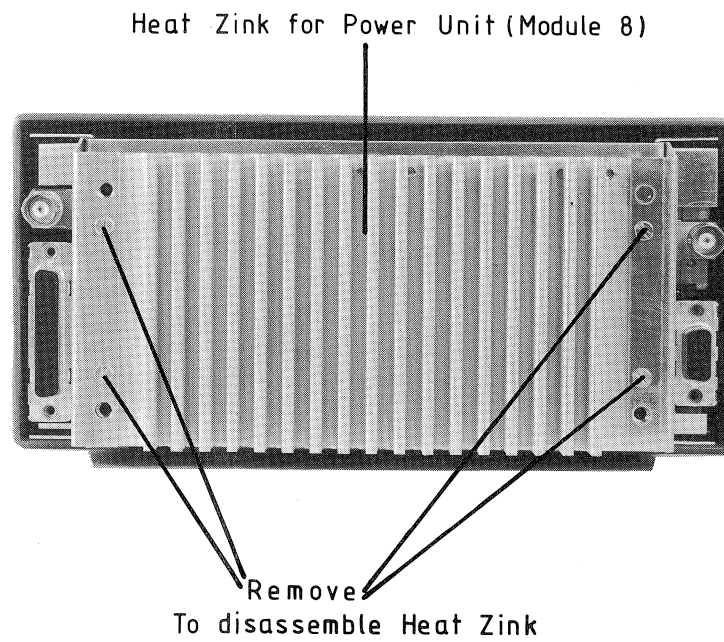
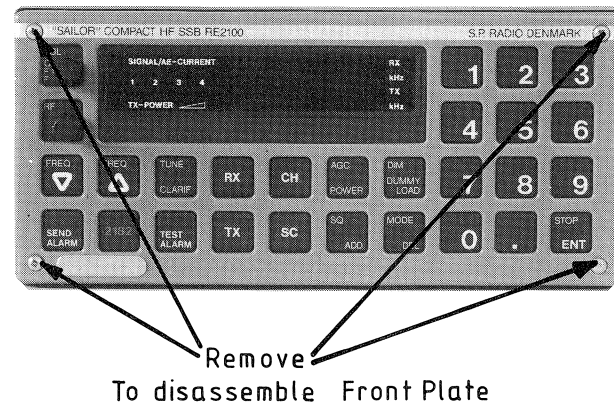
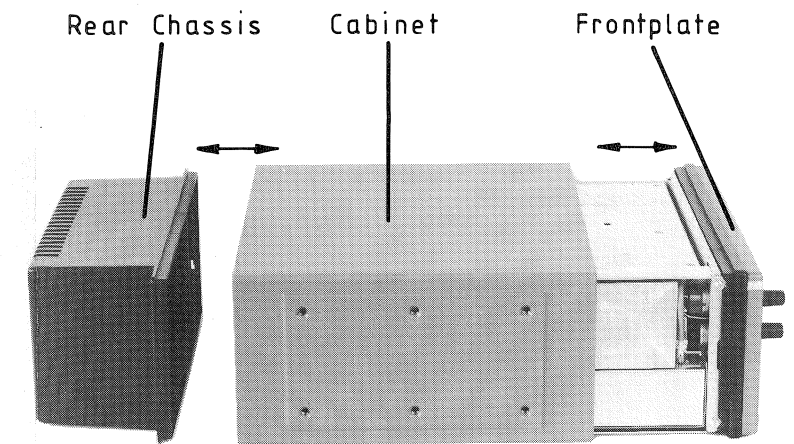
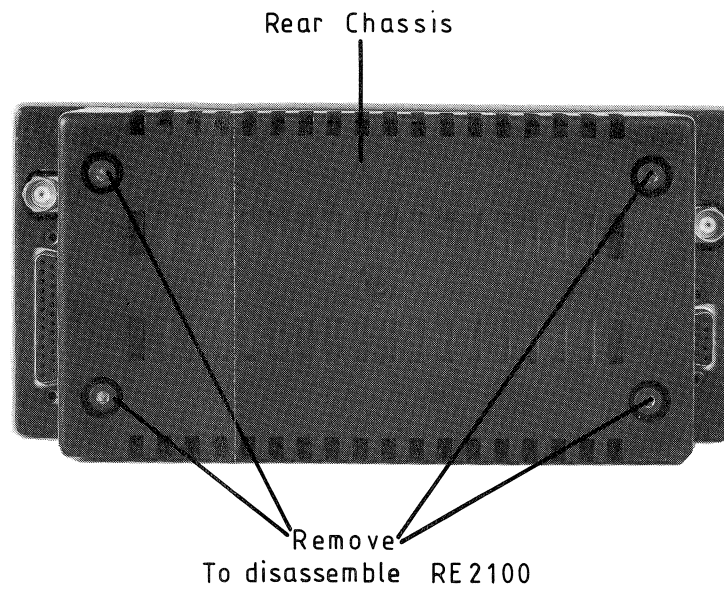
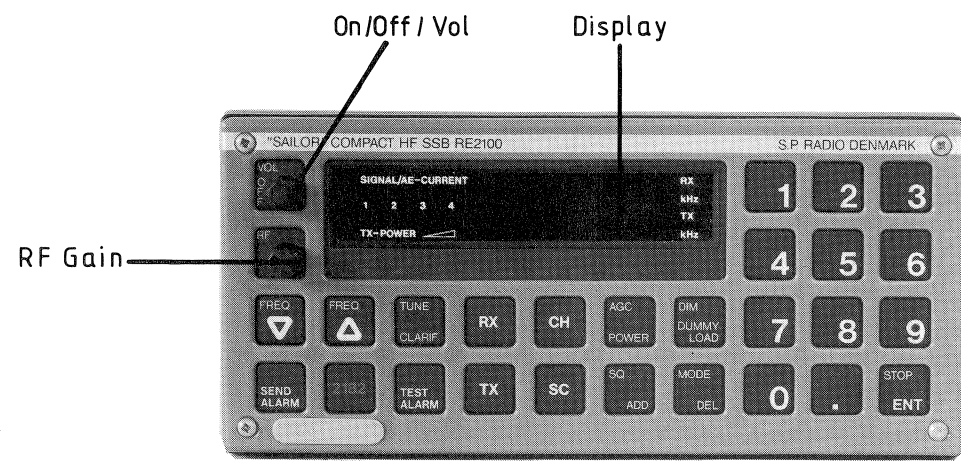

RE2100 FOTO NR. 501004, 501005,  
 501007, 501013 - 501017  
 501035, 501036, 501038, 501046, 4-6-26046

4.1. MECHANICAL DISASSEMBLING AND MODULE LOCATION

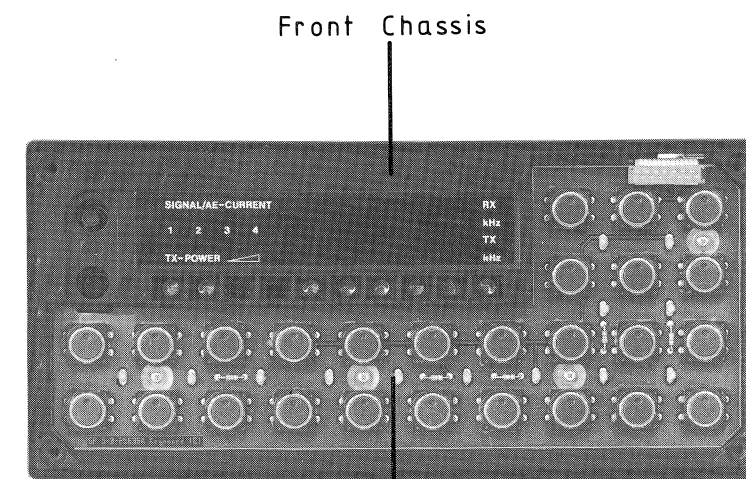
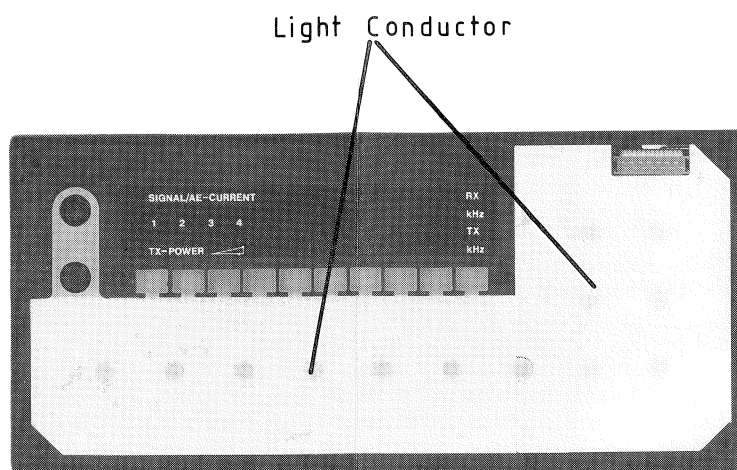
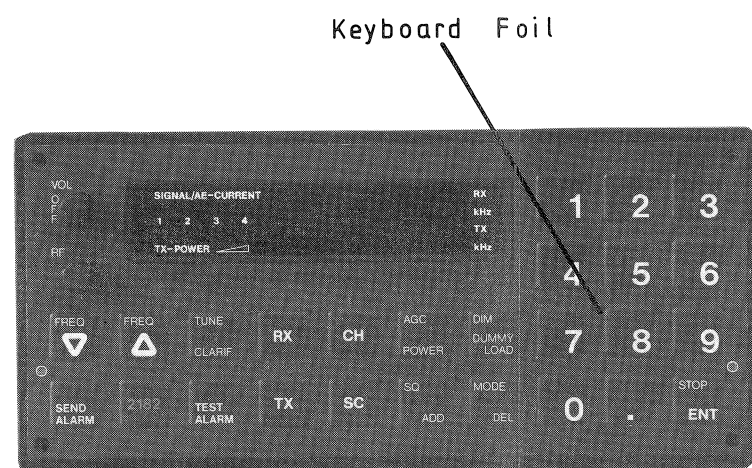

Keyboard Unit (Module 6)

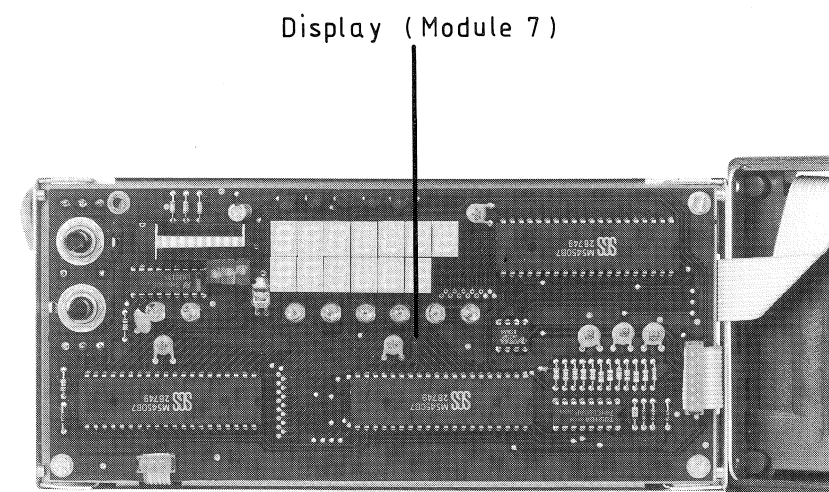
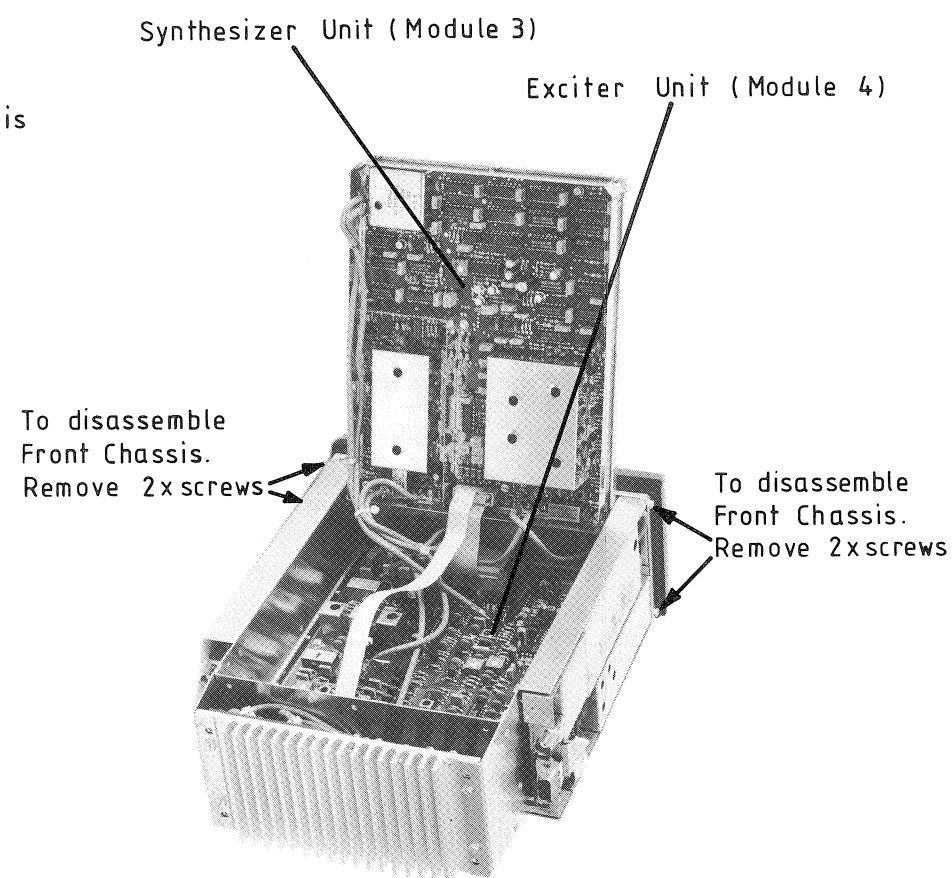
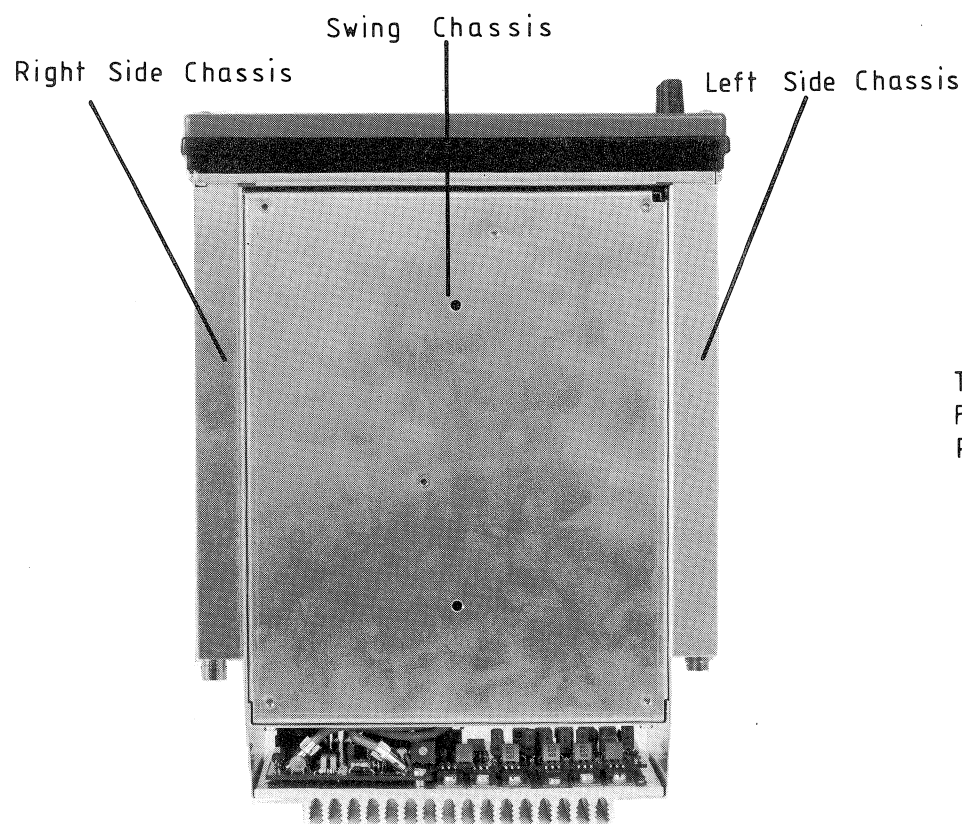

Front Chassis removed.

RE2100 . FOTO NR. 501004, 501005,  
501007, 501013 - 501017  
501035, 501036, 501038, 501046, 4-6-26046

4.1. MECHANICAL DISASSEMBLING AND MODULE LOCATION

Synthesizer Unit (Module 3)

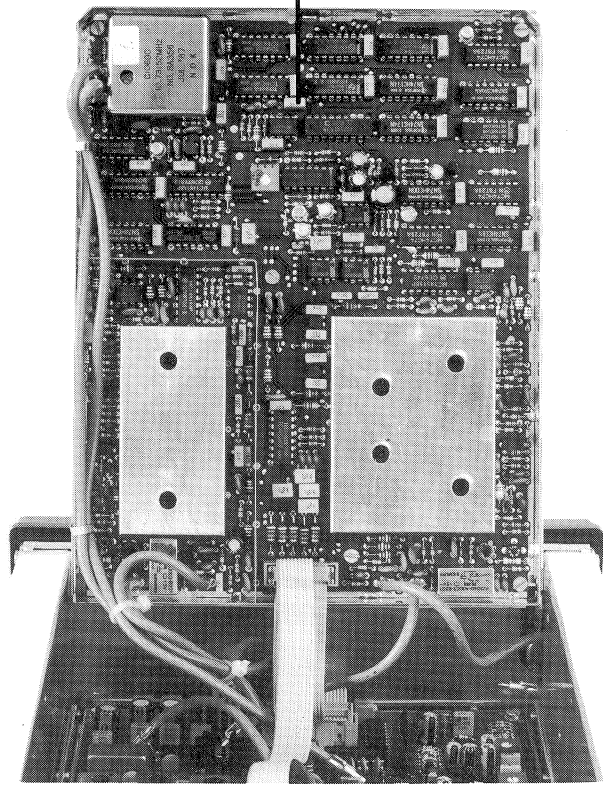

Exciter Unit (Module 4)

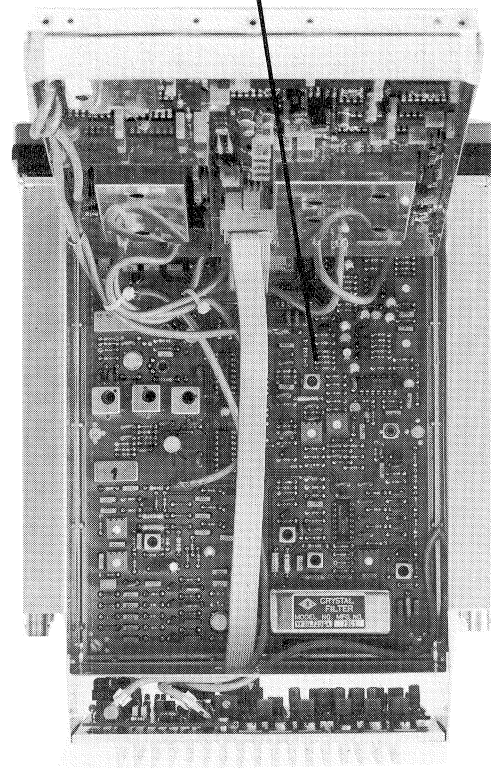

Receiver Unit (Module 1)

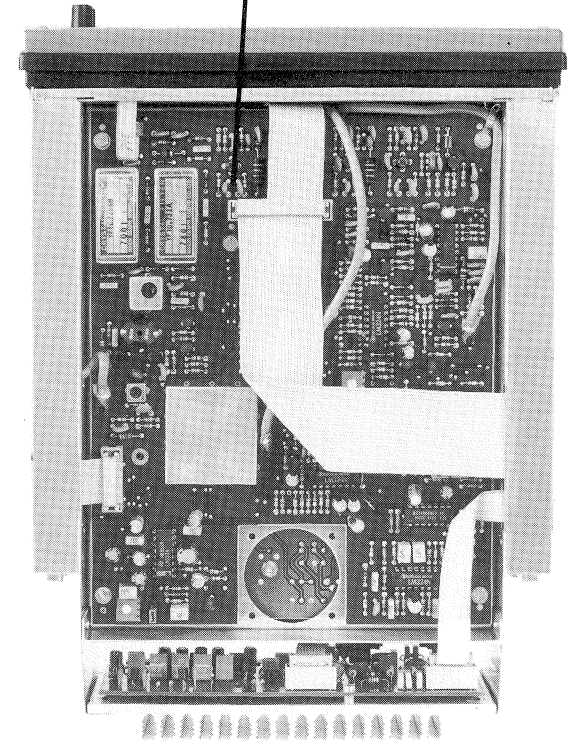

RF Shields

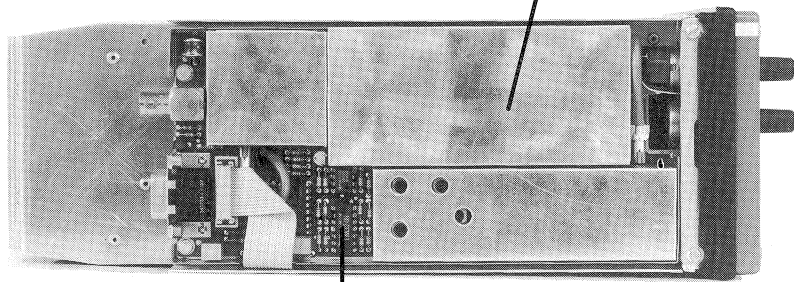

RF Shields

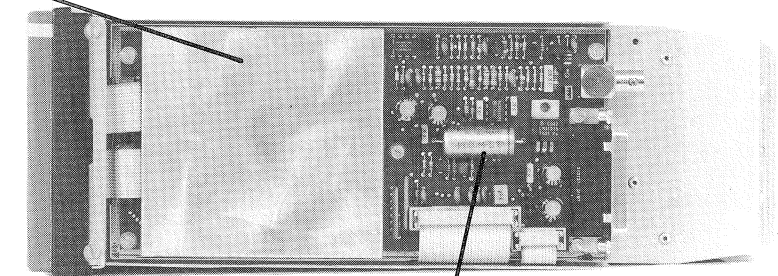
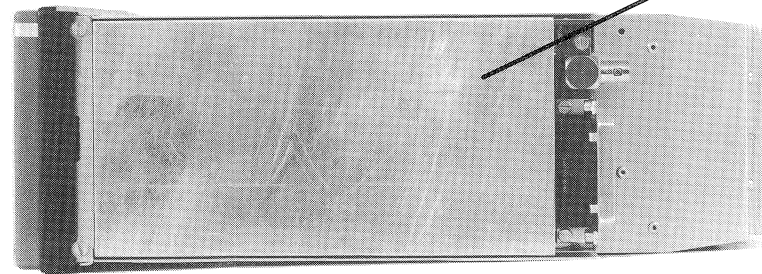

Front End (Module 2)

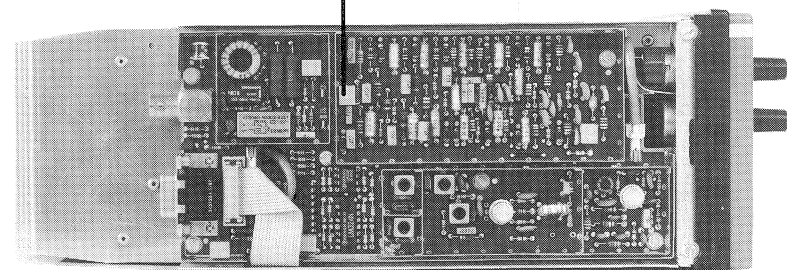

Processor Unit (Module 5)

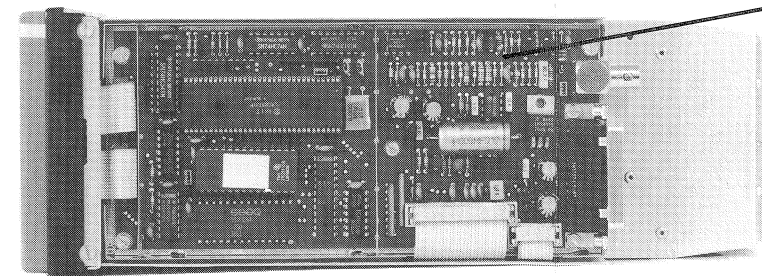

RE2100 FOTO NR. 501018,  
501030 - 501032, 501034  
501037, 501039, 501040, 4-6-26046





## CONTENTS

- 5. CIRCUIT DESCRIPTION AND SCHEMATIC DIAGRAMS
  - 5.1. RECEIVER UNIT (MODULE 1)
  - 5.2. RECEIVER FRONT END (MODULE 2)
  - 5.3. SYNTHESIZER UNIT (MODULE 3)
  - 5.4. EXCITER UNIT (MODULE 4)
  - 5.5. PROCESSOR UNIT (MODULE 5)
  - 5.6. KEYBOARD UNIT (MODULE 6)
  - 5.7. DISPLAY UNIT (MODULE 7)
  - 5.8. POWER UNIT (MODULE 8)
  - 5.9. INTERCONNECTION CABLE DIAGRAM



## 5. CIRCUIT DESCRIPTION AND SCHEMATIC DIAGRAMS

### 5.1. RECEIVER UNIT (MODULE 1)

The receiver unit consists of a 70.0 MHz to 10.7 MHz mixer followed by an SSB/AM filter and a gain regulated IF amplifier. From the amplifier the signal is fed to the detector and low frequency filter unit. The receiver unit contains low frequency derived squelchs which can be set to control the low frequency output.

#### **SECOND MIXER AND CRYSTAL FILTERS**

The signal from the 70 MHz selectivity (module 2) is led through the balanced transformer TR01 to the gates of the J-FET's Q01 and Q02.

The second LO signal from the frequency synthesizer (module 3) is led through the LO-buffer Q03 and BPF (L01, L03, L04, and C04, C05, C11) in order to give about +17 dBm signal to the sources of the FET's. The mixed signals are fed through the balanced transformer TR02 and the impedance matching network (C17-C19 and R10) to one of the two high order monolithic crystal filters FL01 or FL02. The filter selection is controlled by the microprocessor through the shift register U10, pin 2..

#### **IF AMPLIFIER**

The signal from the crystal filters is fed through the diode D07 or D08 to the IF amplifier.

The IF amplifier consists of transistors Q07-Q11 and filter FL03 in cascade.

The gain in Q07, Q08, and Q09, which are dual gate Mos-FET's, is controlled by the AGC voltage applied to gate 2 of the FET's. This is done to keep the input level to the detector at the same level, independent of the input level to the receiver. From Q09 the signal is led to an amplifier built-up around Q10 and further to the ceramic filter FL03, which reduces the noise bandwidth to about 300 kHz. From the ceramic filter, the signal is fed through the emitter follower Q11 to the detector.

#### **AGC GENERATOR**

From the amplifier Q11 the signal is fed to the common emitter amplifier Q16. The voltage gain in this amplifier determines through the AGC system the magnitude of the output from the IF amplifier.

From the amplifier Q16 the signal is fed to transistor Q14, which together with R89, R91, C72, and C71 forms a magnitude detector.

#### **SSB Mode**

In SSB mode the signal from the magnitude detector ensures fast control of the gain in the IF amplifier. A slow control of the gain in the IF amplifier is activated by feeding the detector output voltage to the amplifier U03/2. U03/2 buffers the charging of C69 through D11 and R64 and the charging is removed from C69 through R63.

## 5.1. RECEIVER UNIT (MODULE 1) cont.:

The voltage on C69 is fed through the unity gain buffer U03/1 and D10 to the cathode of D14, where it is added to the actual voltage level from the detector. The added voltage is then subtracted from a reference voltage in U03/3 to make the AGC voltage, which is fed through an LP filter to the gates of Q07, Q08, and Q09.

The fast AGC system ensures noise immunity and the slow AGC system will decrease distortion caused by the AGC on an SSB signal.

### AM Mode

In AM mode C71 is connected parallel to C72 through Q15. This increases both rise and fall time for the (fast) AGC system, so that modulation compression does not occur. The slow SSB-AGC is disabled by shunting C69 through Q04.

The manual IF gain voltage is added to the AGC system through D13. In scan mode the IF gain is set to max., independent of the position of the IF gain potentiometer (on module 7), by short-circuiting the potentiometer with Q12.

To switch the AGC system off, C71 (and C72 in AM mode) is short-circuited with Q13.

All mode shifts in the AGC system are controlled by the microprocessor through the shift register U10.

### DETECTOR

The detector circuit, which can demodulate A3E, H3E, R3E, and J3E is built-up around U05. Switching between the two different detector modes, AM and SSB mode is controlled by the microprocessor through U10, Q17 and the diode switching circuit built-up around D17-D20. AM: D18 and D20 ON, SSB: D17 and D19 ON.

### AM Mode

In AM mode the principle is to remove the modulation from the IF signal through the limiting amplifier (pin 1) and leave just the carrier signal. This signal is then mixed with the original IF signal (pin 9) to create the wanted AF signal (pin 6).

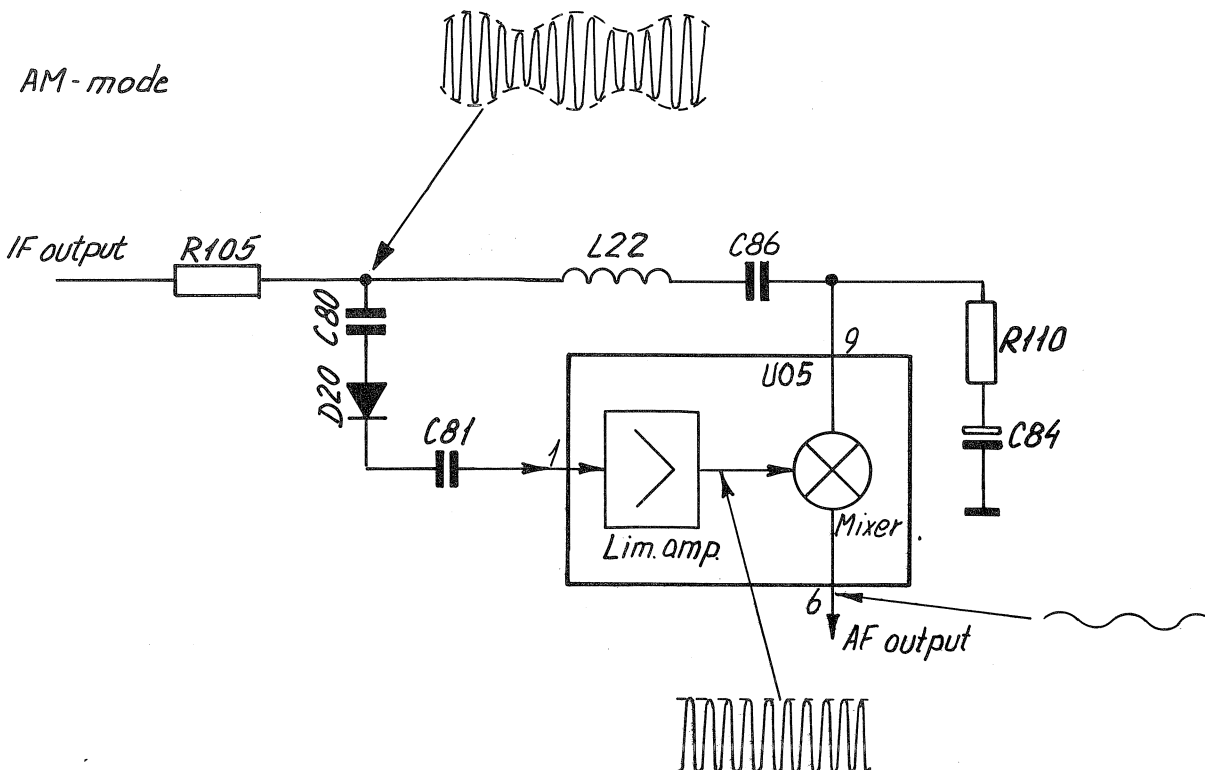

## 5.1. RECEIVER UNIT (MODULE 1) cont.:

### SSB Mode

In SSB mode the carrier reinjection signal (pin 1) is simply mixed with the IF signal (pin 9) and the AF signal is then created.

U05 features a muting facility controlled by the microprocessor by applying voltage to pin 5.

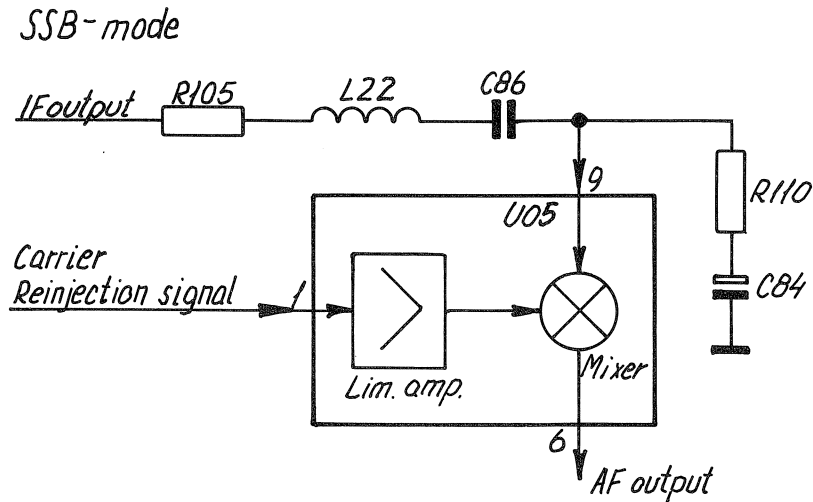

RE2100A / R2122  
4-0-25923B II

### **AF FILTERS**

To reduce white noise from the non-tuned IF amplifier, the AF signal from the detector is led through three active filters in cascade.

A 5th order, 3 kHz lowpass filter is built-up around U04/3 and U04/4.

A 3rd order, 70 Hz highpass filter is built-up around U04/1, and a 3rd

order, 350 Hz highpass filter is built-up around U04/2.

### AM Mode

In AM mode only the LP filter and the 70 Hz HP filter is used. This is done by applying a logic high voltage to the analog switch U07, pin 9.

### SSB Mode

In SSB mode all filters are used by applying a logic low voltage to the analog switch U07, pin 9.

Filter selection is controlled by the microprocessor through the shift register U10, pin 2.

## 5.1. RECEIVER UNIT (MODULE 1) cont.:

### AF SWITCHES

From the output of the AF filter, the signal is fed through a number of analog switches, which are all included in the three IC's U7, U8, and U9. These switches are used to control the transfer of AF signals between the RE2100 and the peripheral equipment, which as an example could be a telex modem, a duplex receiver, and one or more remote control units. The interconnection between the individual switches is shown in the block diagram below.

### Block Diagram AF Switches

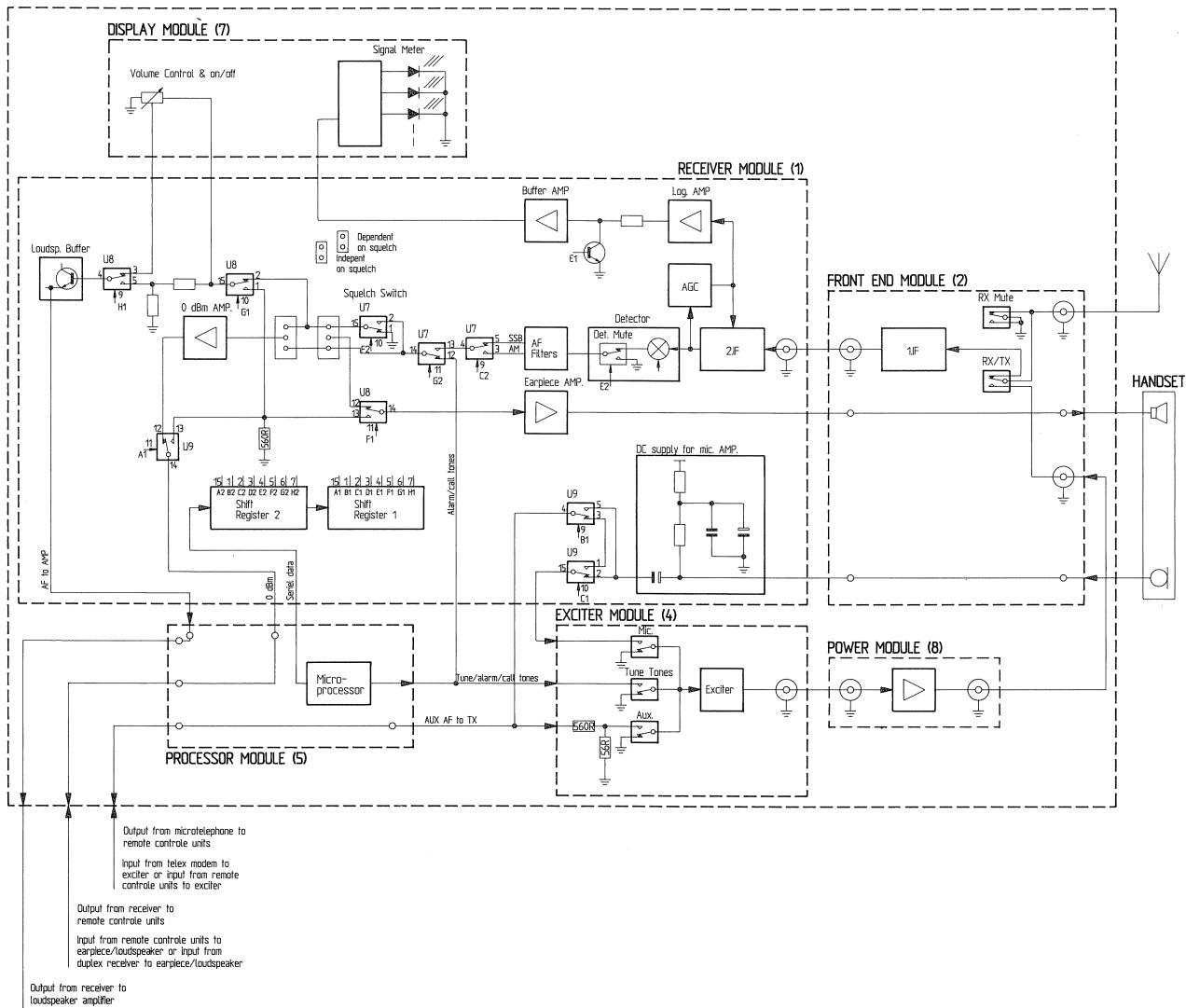

### AF OUTPUT AMPLIFIERS

From the AF switches, the signals are led to three different output amplifiers, which are described below.

#### AF Pre. Amplifier (Loudspeaker Output)

The purpose of the Pre. Amplifier is to buffer the AF signal before it is led to the power amplifier placed on module 4 in T2130. The output level can either be controlled by the volume potentiometer or by a constant voltage divider. The constant voltage divider is used in the situation where an intercom call to the RE2100 is detected. This situation is indicated by a ringing tone in the loudspeaker and to avoid this tone from vanishing it must necessarily be kept independent of the volume potentiometer.

## 5.1. RECEIVER UNIT (MODULE 1) cont.:

### Earpiece Amplifier

The input signal to the earpiece amplifier is fed through the adjustable resistor R52, where the output level can be selected. The earpiece output can be means of P1 be selected to follow the squelch or not.

### 0 dBm Amplifier

In this amplifier the AF signal is amplified in order to give a 0 dBm output (in 600 ohm). The 0 dBm signal is led to the remote control units and it can by means of P4 be selected to follow the squelch or not.

## **SQUELCH**

The squelch is voice activated, which is realized by detecting whether there is a change in the mean frequency at the AF-filter output. The squelch circuit, which contains limiting amplifier, frequency to voltage converter, voltage change detector, and hold circuit, generates a signal by which the microprocessor controls the squelch switch U07 at the receiver output.

### Limiting Amplifier

U02/2 and U02/1 are connected as amplifier with about 100 dB voltage gain so that the output from U02/1 will be square wave with the same frequency as the input signal from the AF filter.

### Frequency to Voltage Converter

The signal from the limiting amplifier is fed to the frequency to voltage converter, built-up around C99-C100, D26-D27, R142, and U02/4. The output from the converter is a voltage with an amplitude depending on the input frequency.

### Voltage Change Detector

The voltage from the frequency to voltage converter is fed to capacitor C98 which only will pass a variation in the DC voltage. The resulting signal is amplified and filtered in the circuit built around U02/3. The inverter U01/3 and D22-D23 provide both positive and negative changes in the voltage to be converted to a positive change before the signal reaches the hold circuit.

### Hold Circuit

The hold circuit has two functions. Fast opening for the AF signal when a conversation begins and keeping it open for a period after the conversation stops, e.g. during a short interruption of the conversation.

The signal from the voltage change detector is fed to comparator U01/4, which goes high and buffers the charging of C95 through D21 and R120 when the input signal is higher than the reference voltage (determined by R127-R128). The charging is removed from C95 through R119. As long as the voltage on C95 is higher than the reference voltage determined by R117-R118 the output from the comparator U01/1 will be high.

## 5.1. RECEIVER UNIT (MODULE 1) cont.:

### Microprocessor Controlling

The output from the comparator U01/1 is led to the microprocessor. If the microprocessor detects a high voltage, it will turn the squelch switch ON and the AF-signal will then reach the loudspeaker, the earpiece and the 0 dBm amplifier.

When a conversation stops, C95 will slowly be discharged through R119. After about seven seconds the voltage across C95 will fall below the reference voltage and the output of comparator U01/1 will go low. This will be detected by the microprocessor, which will turn the squelch OFF.

In scan mode the squelch circuit is used to control scanning by detecting whether the receiver is scanning a channel with voice activity.

If the microprocessor detects a high voltage at the output of the comparator U01/1, it will immediately reset it by discharging C95 through Q20.

If the receiver actually receives a voice signal it will quickly build-up a new voltage across C95 and the output of the comparator will go high again. This cycle of measuring the comparator voltage and resetting it will be repeated six times to prevent noise spikes from stopping the scanning.

If the microprocessor after these six dischargings still detects a high voltage, it will stop the scanning for a period of about 3 secs. In this period the squelch switch will be turned ON and the AF signal will then reach the loudspeaker.

### **SIGNAL STRENGTH DETECTOR**

The signal strength detector generates a DC voltage to light the LED bar at the display unit (module 7). The circuit consists of a logarithmic amplifier and a buffer amplifier.

### Logarithmic Amplifier

The AGC voltage is fed to the input of the operational amplifier U03/4. With the potentiometer R76 the output voltage is adjusted so that the first LED in the bar is just about to light with no antenna connected to the receiver. Because of R69, R72, and D12 the amplifier has an approximately logarithmic characteristic, which means that the RF signal level must be much higher to light the last LED's than to light the first LED's.

### Buffer Amplifier

The output from the logarithmic amplifier is fed to a voltage divider, which consists of the resistor R213 and the transistor Q18. With this voltage divider it is possible to ground the signal strength voltage and thereby turn off the light in the LED bar. From the voltage divider, the signal is fed to the unity gain buffer U01/2. This buffer is included to avoid the loading by the resistor R213, which is necessary for the wanted function of the voltage divider.





RECEIVER UNIT (MODULE 1)

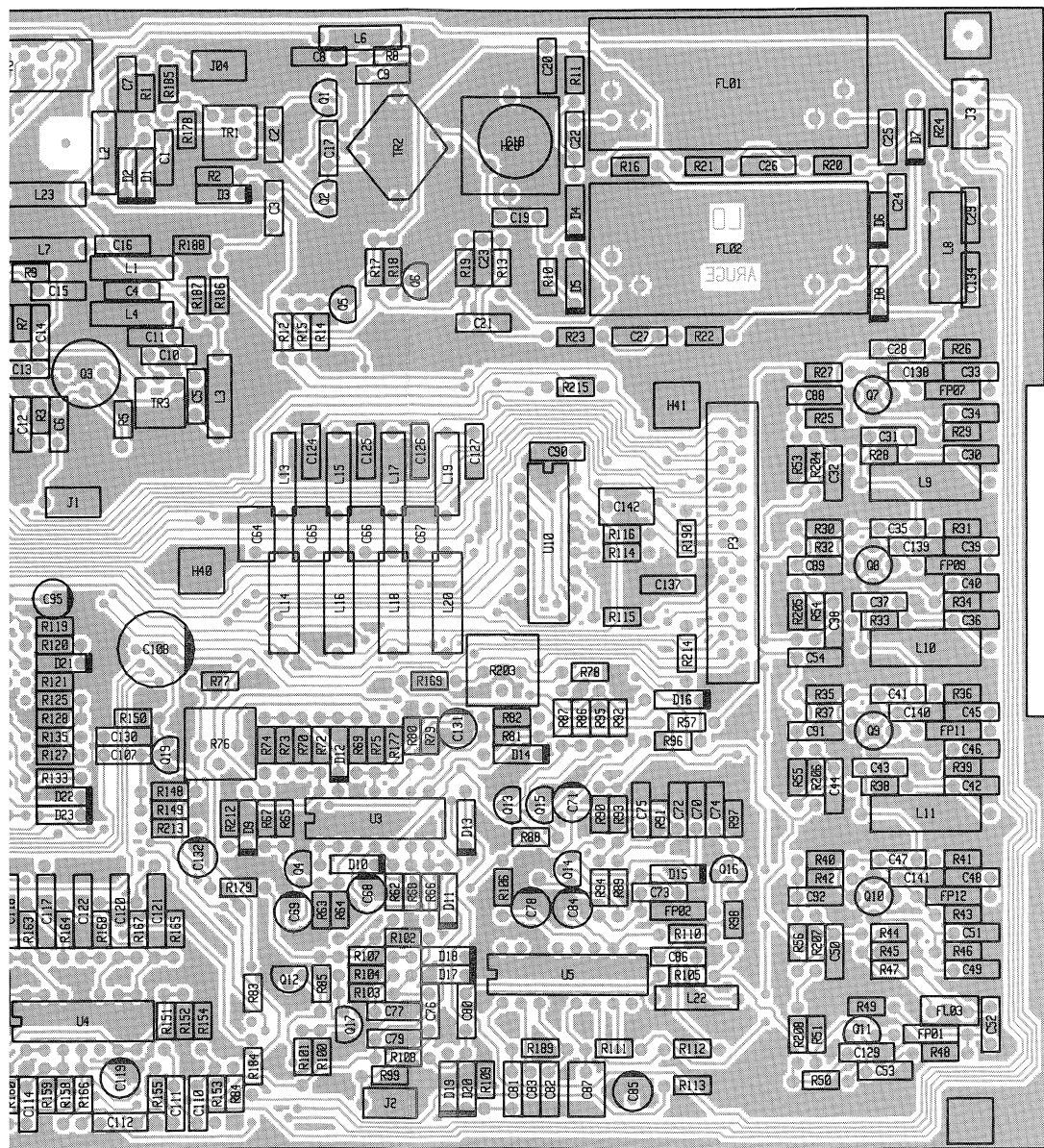

h upper side tracks.

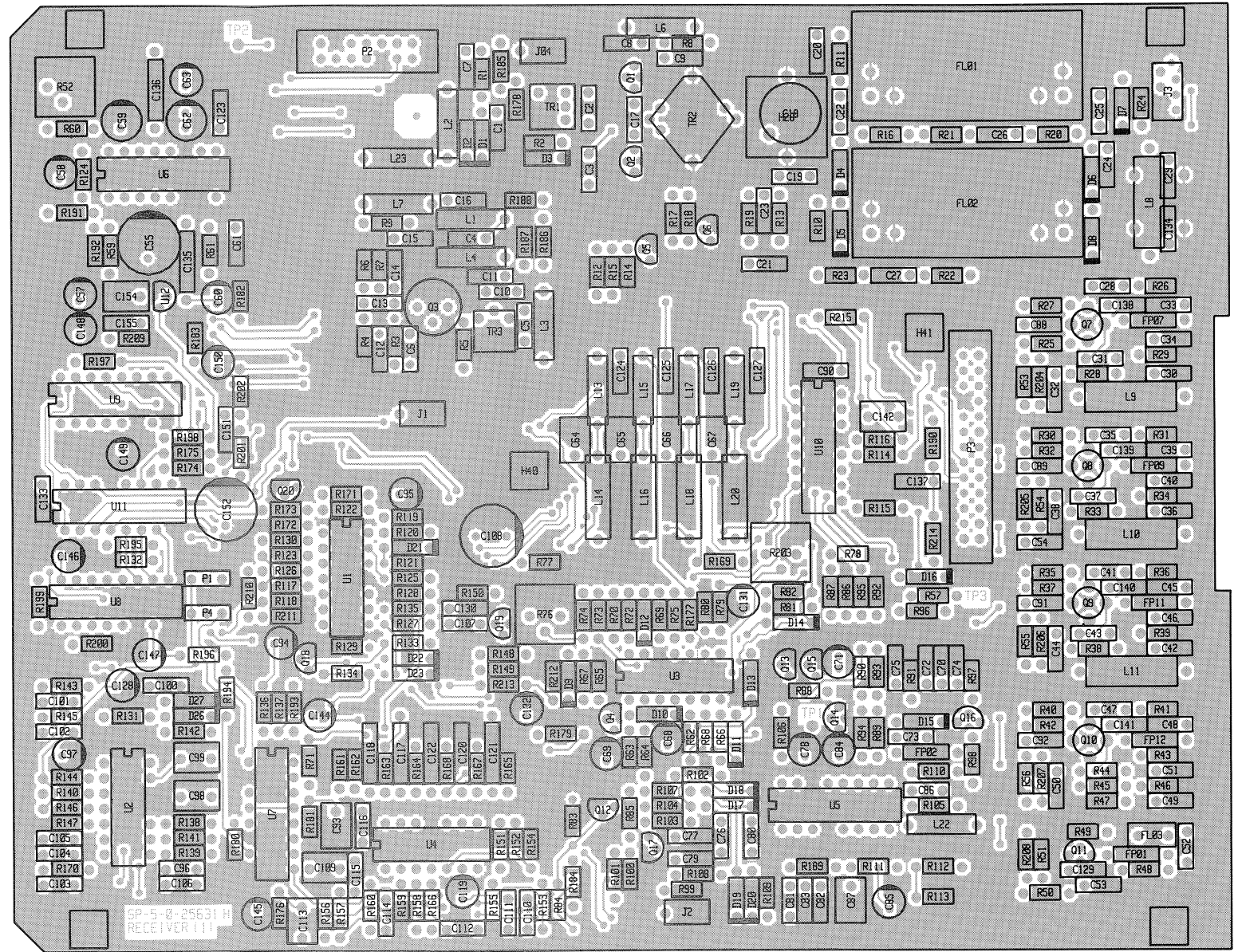

View from component side with lower side tracks.



# 5.1. COMPONENT LOCATION RECEIVER UNIT (MODULE 1)

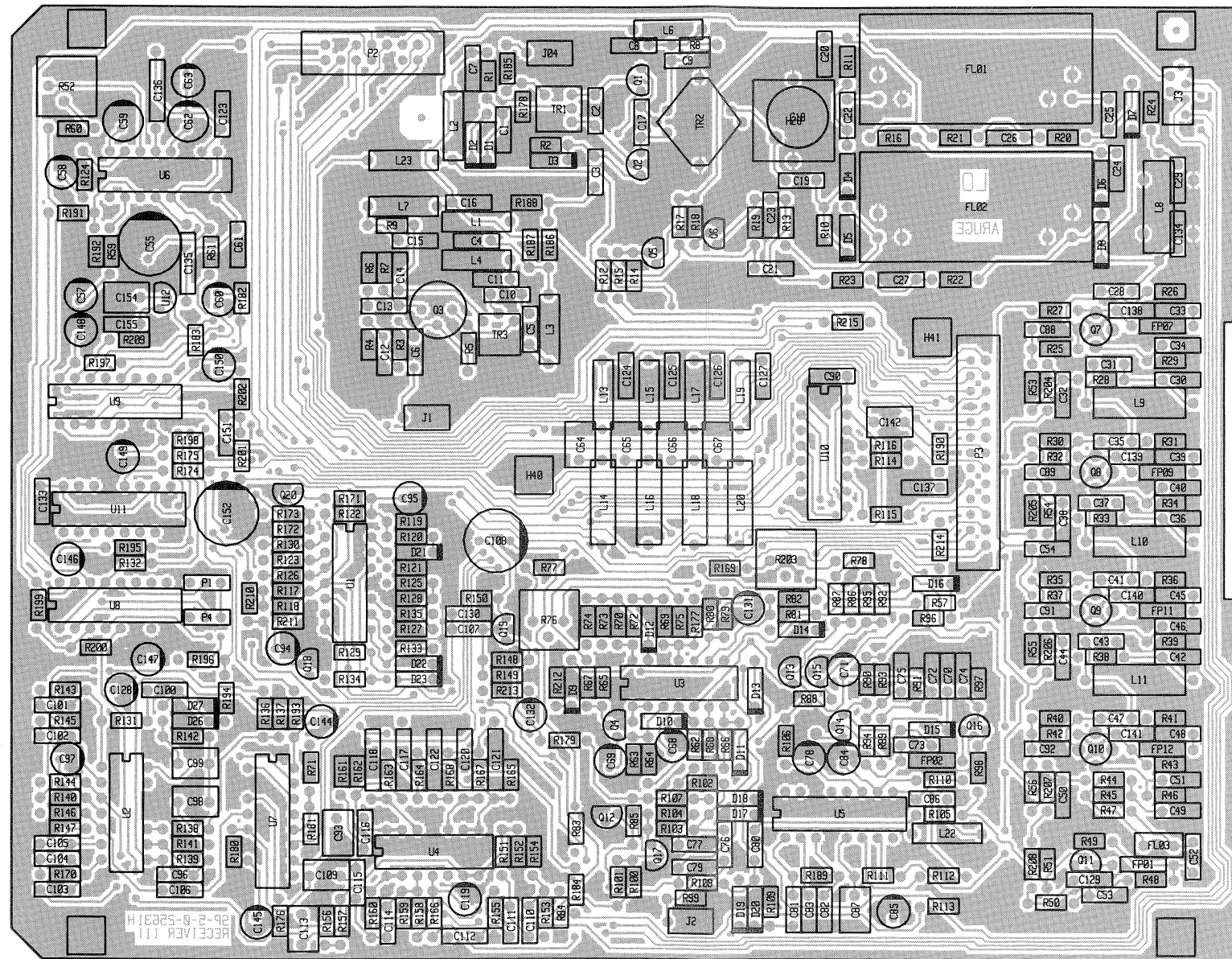

View from component side with upper side tracks.

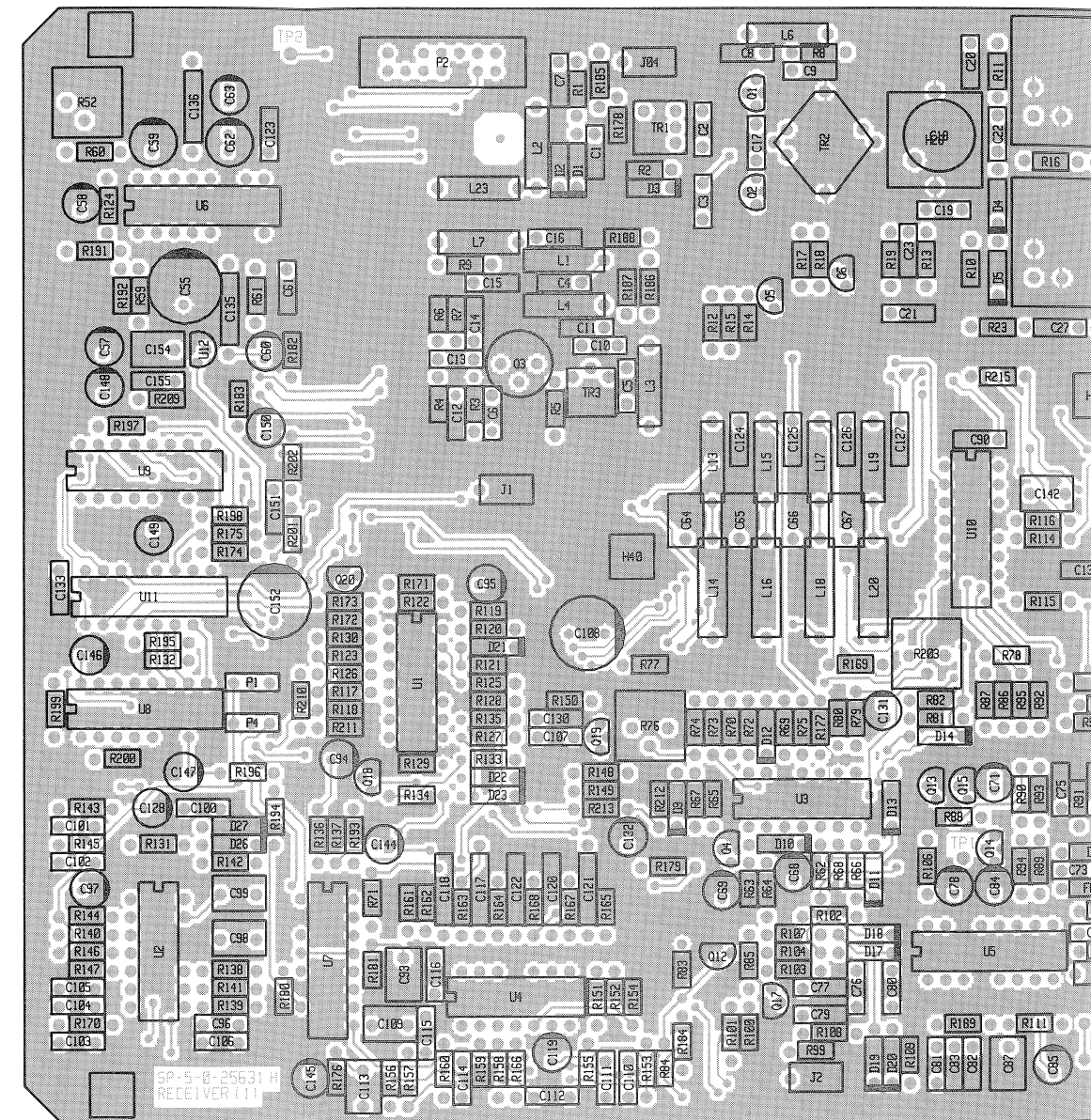

View from component side with lower side tracks.

# TEST CONDITIONS

- Receiver frequency :  $f_{RX} = 2058.24\text{kHz}$
  - Receiver mode : J3E/USB
  - Generator frequency:  $f_G = 2059.24\text{kHz}$
  - Generator level :  $V_G = 117\text{dB}/\mu\text{V} \Rightarrow P_G = 4\text{dBm}$
  - Generator mode : CW
- The generator signal must be feed to the aerial socket at the Front End Unit.

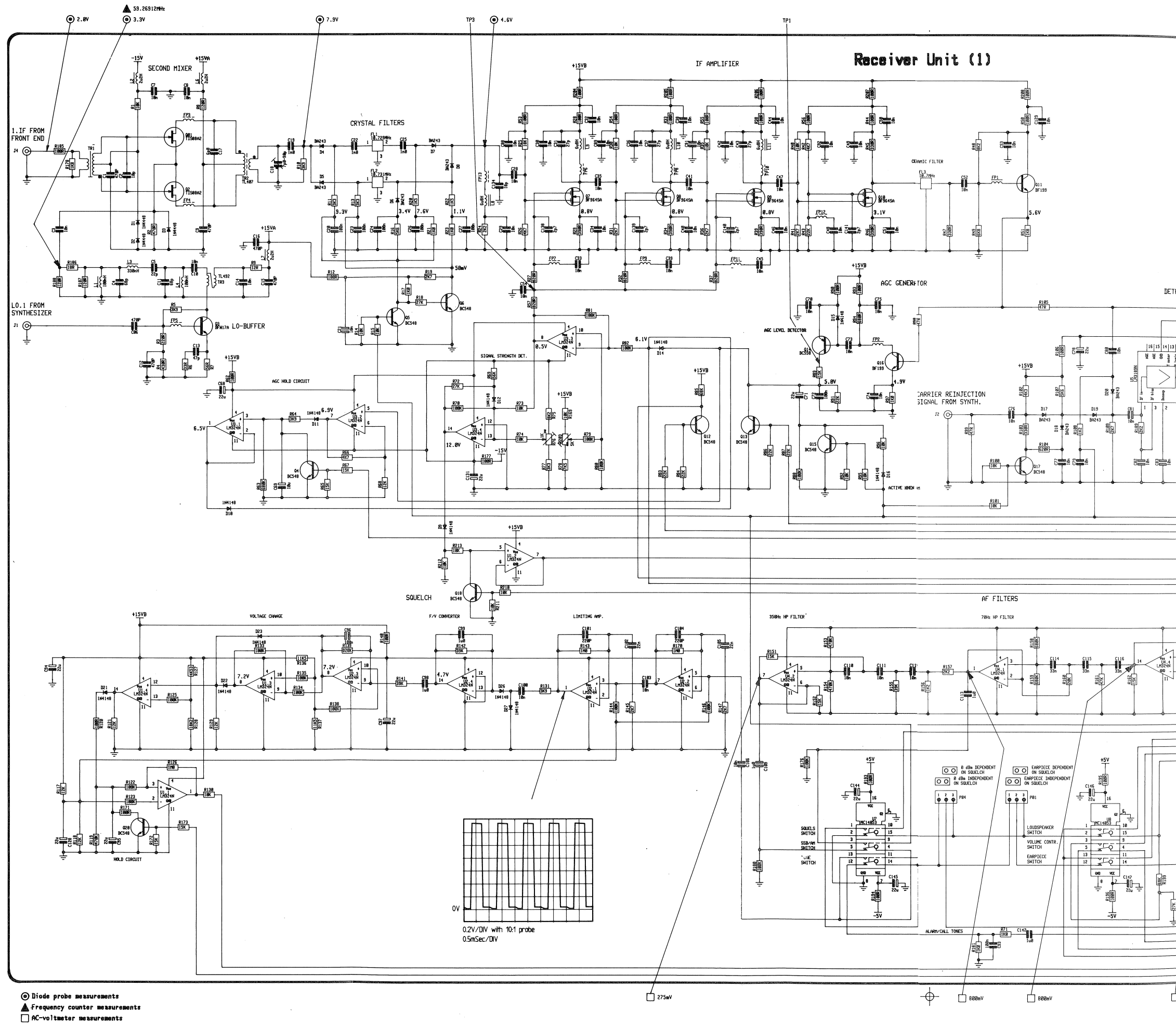

RE2100 / R2122  
4-0-256311L



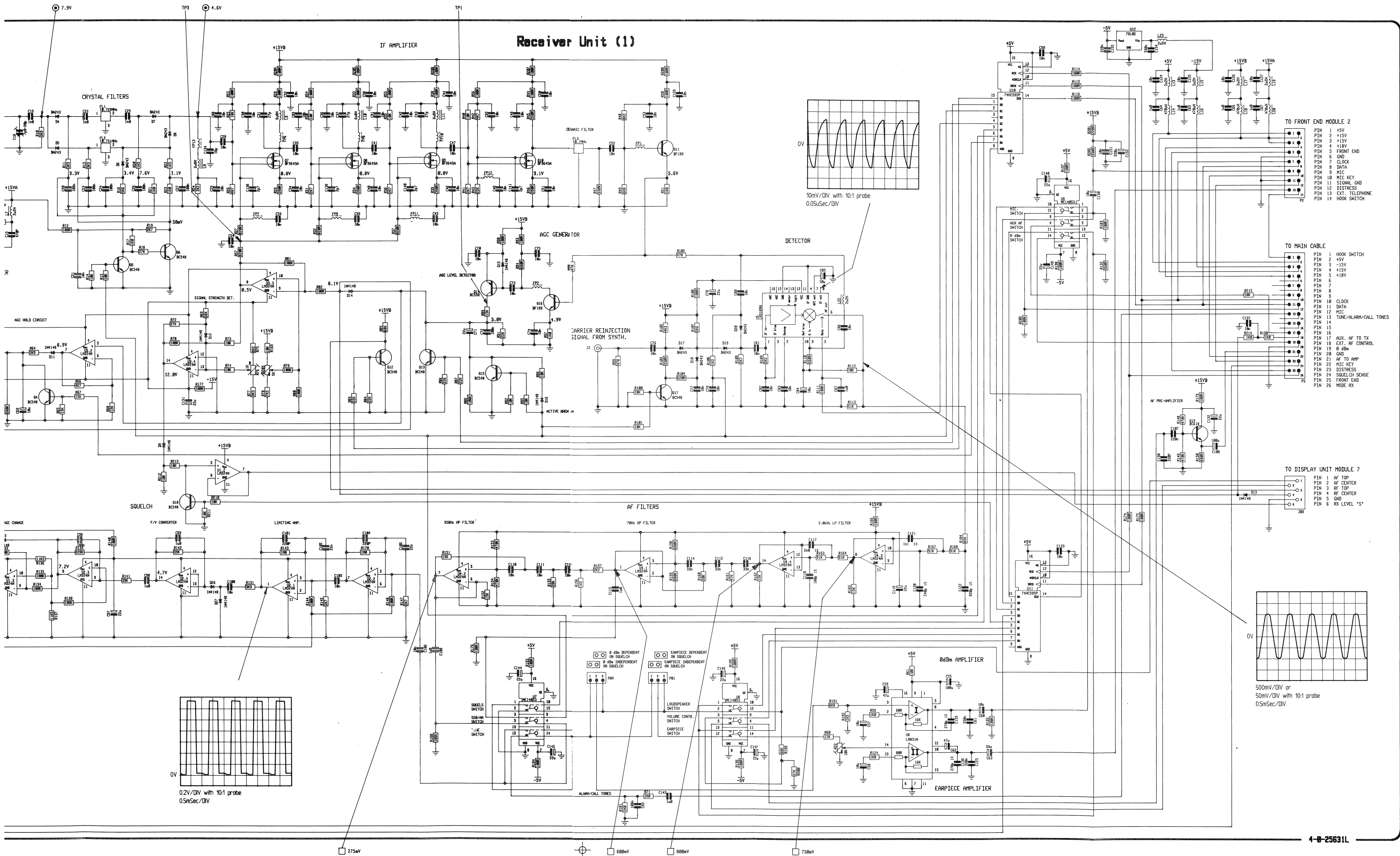

- TO FRONT END MODULE 2**
- PIN 1 +5V
  - PIN 2 +15V
  - PIN 3 +15V
  - PIN 4 +18V
  - PIN 5 FRONT END
  - PIN 6 GND
  - PIN 7 CLOCK
  - PIN 8 DATA
  - PIN 9 MIC
  - PIN 10 MIC KEY
  - PIN 11 SIGNAL GND
  - PIN 12 DISTRESS
  - PIN 13 EXT. TELEPHONE
  - PIN 14 HOOK SWITCH

- TO MAIN CABLE**
- PIN 1 HOOK SWITCH
  - PIN 2 +5V
  - PIN 3 -15V
  - PIN 4 +15V
  - PIN 5 +18V
  - PIN 6
  - PIN 7
  - PIN 8
  - PIN 9
  - PIN 10 CLOCK
  - PIN 11 DATA
  - PIN 12 MIC
  - PIN 13 TUNE/ALARM/CALL TONES
  - PIN 14
  - PIN 15
  - PIN 16
  - PIN 17 AUX. AF TO TX
  - PIN 18 EXT. RF CONTROL
  - PIN 19 8 dBm
  - PIN 20 GND
  - PIN 21 AF TO AMP
  - PIN 22 MIC KEY
  - PIN 23 DISTRESS
  - PIN 24 SQUELCH SENSE
  - PIN 25 FRONT END
  - PIN 26 MODE RX

- TO DISPLAY UNIT MODULE 7**
- PIN 1 AF TOP
  - PIN 2 AF CENTER
  - PIN 3 RF TOP
  - PIN 4 RF CENTER
  - PIN 5 GND
  - PIN 6 RX LEVEL \*5\*





## 5.2. RECEIVER FRONT END (MODULE 2)

This module consists of a transmit/receive relay and the receiver front end. The front end consists of a receiver input protection circuit, a radio frequency filter unit, a radio frequency to first intermediate frequency (70 MHz) mixer, and a first IF (70 MHz) filter unit.

### AERIAL/EXCITER SWITCH

The aerial signal enters the receiver through the aerial/exciter socket J01, when relay RE02 is in RX position. The exciter signal from the power module (8) is connected to relay RE02 through the EX socket J04. When relay RE02 is in TX position the exciter signal will pass through the aerial/exciter socket J01 and a coax cable to the HF power amplifier in T2130. Switching between RX and TX with RE02 is controlled from the microprocessor through register U01 and Q02.

### INPUT PROTECTION

Protection of the pre-filters and the first mixer is done with R02, R03, TR01 and the circuit around D05, and it guaranties that the voltages to the pre-filters cannot be higher than about 4.5V. In addition the RX input is grounded with relay RE01 when the transceiver is switched off.

### PRE-FILTERS

The pre-filters consists of the following units:

- 100 kHz HPF consisting of L01-L02 and C08
- 385 kHz LPF (1) consisting of L29, C49-C50 and D16-D17
  
- 385 kHz - 1.6 MHz BPF (2) consisting of L24-L26, C42-C44 and D14-D15
- 1.6 MHz - 4.5 MHz BPF (3) consisting of L20-L22, C36-C38 and D12-D13
- 4.5 MHz - 9 MHz BPF (4) consisting of L16-L18, C30-C32 and D10-D11
- 9 MHz - 18 MHz BPF (5) consisting of L12-L14, C24-C26 and D08-D09
- 18 MHz - 30 MHz BPF (6) consisting of L09-L11, C18-C20 and D06-D07
- 30 MHz LPF consisting of L31-L33, and C54-C56

The switching between the filters is controlled from the microprocessor through U01, U02 and U03.

### FIRST MIXER AND IF-FILTER

The first mixer is an active J-FET mixer with good, large signal properties and low noise factor.

The signal is led through the balanced transformer TR03 to the sources of the dual J-FET Q04. The first LO signal from the frequency synthesizer (module 3) is led through the LO buffer (Q03) to give about +17 dBm signal to the gates of the two J-FET transistors. The mixed signals are fed through the balanced output transformer TR04 to the two high order biliteric crystal filters FL01 and FL02 where the wanted 70 MHz signal is selected. The selected signal is then fed on to the receiver PCB (module 1)

5.2. COMPONENT LOCATION RECEIVER FRONT END (MODULE 2).

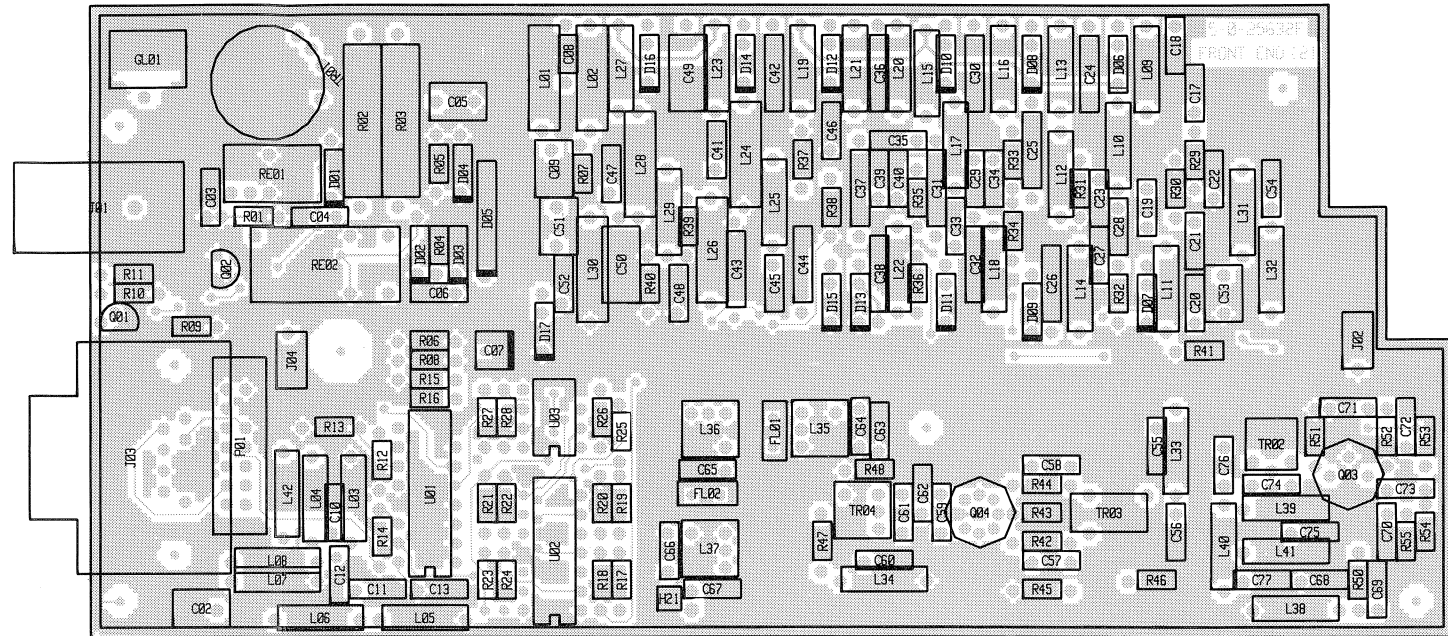

View from component side with upper side tracks.

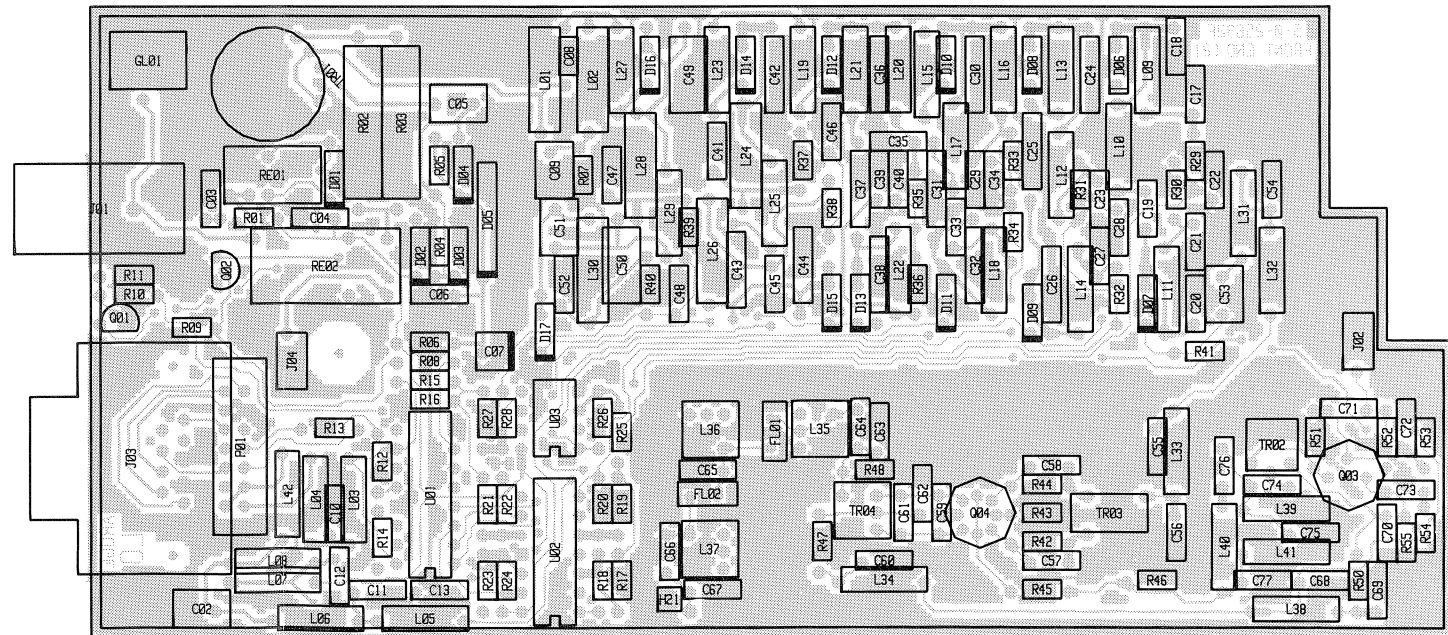

View from component side with lower side tracks.

# TEST CONDITIONS

Receiver frequency :  $f_{RX} = 2058.24\text{kHz}$

Receiver mode : J3E/USB

Generator frequency:  $f_G = 2059.24\text{kHz}$

Generator level :  $V_G = 117\text{dB}/\mu\text{V} \Rightarrow P_G = 4\text{dBm}$

Generator mode : CW

The generator signal must be feed to the aerial socket at the Front End Unit.

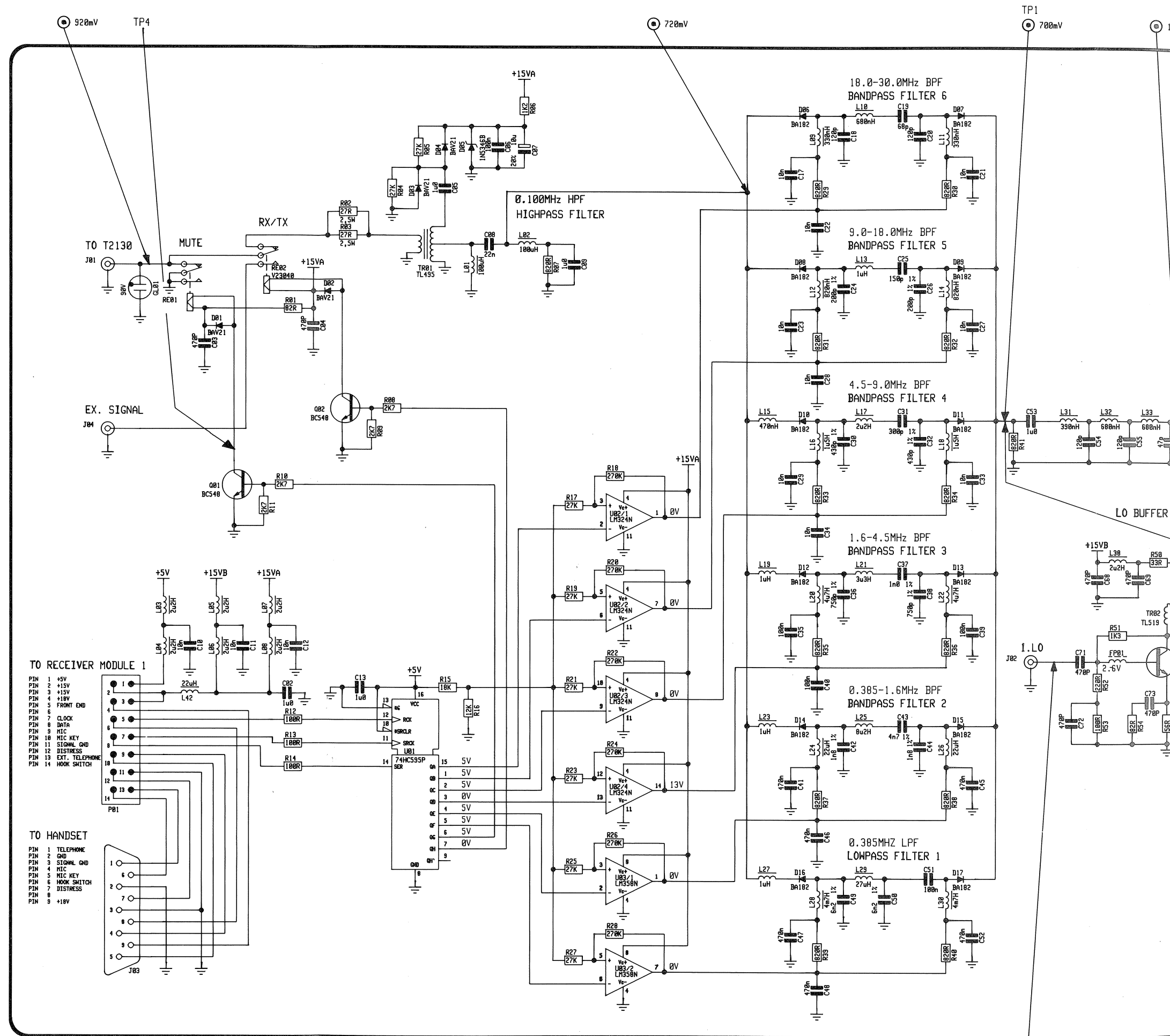

⊙ Diode probe measurements  
 ▲ Frequency counter measurements

1.5V

RE2100 / R2122  
 4-0-25632G



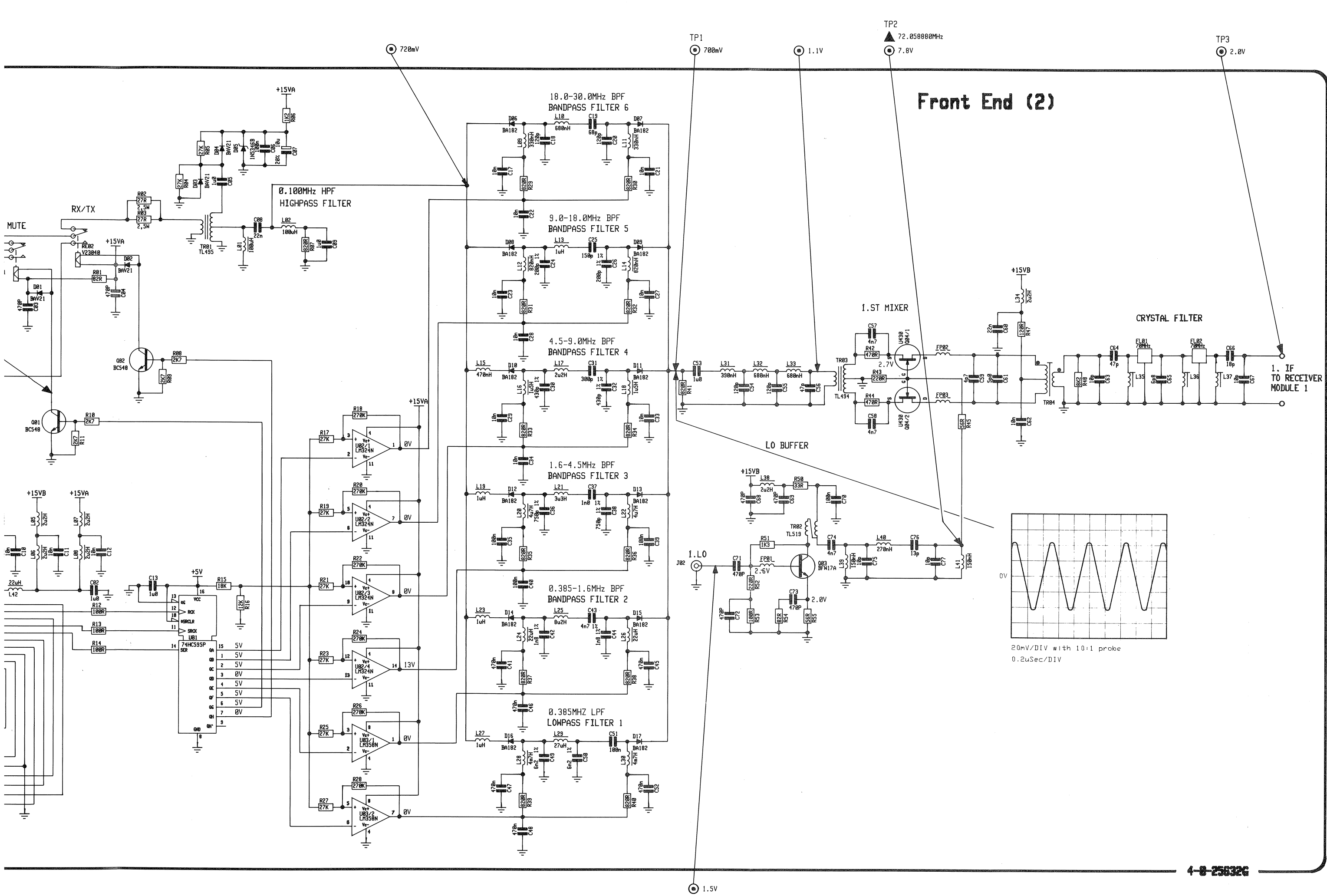

4-8-25832G



### 5.3. SYNTHESIZER UNIT (MODULE 3)

The synthesizer unit consists of two phase locked loops. Phase locked loop 1 generates the signal used as injection to the first mixer in the front end module and as the injection to the second mixer in the exciter unit. The PLL1 signal has a frequency range from 70 MHz to 100 MHz in steps of 10 Hz.

Phase locked loop 2 generates the injection signal to the first mixer in the exciter unit and the injection signal to the second mixer in the receiver unit. The PLL2 signal changes between two frequencies 80.7 MHz and 59.3 MHz when the transmitted or received sideband is changed between upper and lower sideband.

#### PHASE LOCKED LOOP 1

PLL1 operates as a fractional synthesizer. This means that the dividing figure in the loop can be set to a non-integer number, making it possible to get a frequency resolution at the VCO output which is smaller than the reference frequency in the loop. The reference frequency is 40.96 kHz and the frequency resolution is 10 Hz. The reference frequency is derived from a TCXO, which oscillates at 10.73152 MHz. Furthermore the TCXO signal is used as carrier signal for both detector in the receiver and SSB generator in the exciter.

The principle in a fractional synthesizer is that the integer number dividing figure  $N_i$  in the loop is changed at particular times to  $(N_i+1)$  determined by the value of fraction number  $F$ . By this method the mean frequency of the VCO is increased as illustrated in the example below:

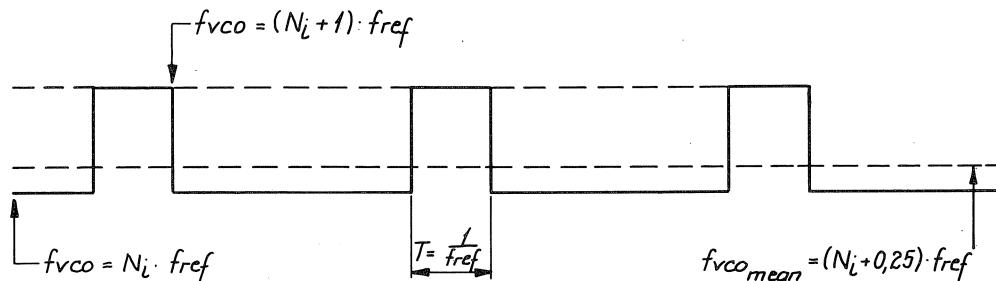

In the example the integer dividing figure is changed every fourth reference cycle implying an increase in mean VCO frequency.

Because of the change in the integer number, dividing figure spurious sidebands occur at the VCO output. These sidebands have to be reduced and this is done through a correction signal fed to the phase detector. The correction signal is generated in the API (Analog Phase Interpolator) circuit.

#### VOLTAGE CONTROLLED OSCILLATORS

The frequency range from 70-100 MHz is covered with four independent oscillators:

VCO I	:	70	-	77.5	MHz
VCO II	:	77.5	-	85	MHz
VCO III	:	85	-	92.5	MHz
VCO IV	:	92.5	-	100	MHz

### 5.3. SYNTHESIZER UNIT (MODULE 3) cont.:

The oscillators are in principle identical and each of them is built-up around an earthed drain FET amplifier, where the output signal is fed back to the input by means of two capacitors. The ratio of the capacitors determines the amount of feed-back in the oscillator. The oscillator frequency is determined by the LC circuit located on the gate of the FET, and the tuning of oscillator frequency is done by means of variable capacitance diodes.

The output signal from the VCO's is led through switch diodes D2, D5, D7, and D10 to a common buffer amplifier Q13, which buffers the VCO signal for prescaler buffer and LO buffer respectively.

Selection of the wanted VCO circuit is done by Q1, Q3, Q4, Q6, Q7, Q9, Q10, and Q12. The control of these transistors is done by serial to parallel register U1.

#### PASSIVE LOOP FILTER

The components R28, R31, C11, C51, C54, and L22 constitute a chebychev lowpass filter with cut-off frequency equal to approximately 10 kHz.

The major task of the passive filter is to prevent spurious signals arising from the phase detector and divider circuit, to modulate the VCO and generate sidebands to the VCO output signal.

#### ACTIVE LOOP FILTER

The filter consists of U16, C66, R33, and R38. The filter secures stabilization in the loop system and is of vital importance in determination of the loop system bandwidth.

#### PHASE DETECTOR

The phase detector is of the sample and hold type. The detector consists of a sequential phase detector followed by the current switch, the ramp generator and the sample and hold circuit.

U26 together with U27 form the sequential phase detector which converts the phase difference between the reference signal and the signal from the programmable divider to a square wave signal measurable on U26 pin 6. The duty cycle of the square wave signal is inverse proportional to the phase difference.

The sequential phase detector controls the current switch, which is built-up around Q25, D17, R93, D16, and D15. When the signal on basis of Q25 is at high state, D16 is switched on, the potential on the cathode of D15 is increased, and D15 is switched off.

When the signal on basis of Q25 is at low state, D16 is switched off, the potential on the cathode of D15 is decreased, and D15 is switched on. The amount of current flowing through D15 and D16 respectively is determined by the current mirror circuit described elsewhere.

The ramp generator, built-up around U21 and C112, integrates the current drawn from U21 pin 2 in regard to time. The ramp generator output voltage is then linear in regard to the size of current flowing through the switch diode D15 and the period of time the diode is switched on.

Q24 connected in parallel to C112 constitutes a switch, which resets the ramp generator by discharging C112.

The switch is open when the gate voltage is at low state and vice versa.

The ramp generator and current switch connected with the sequential phase detector imply a phase detector where the output voltage, in a certain period of time in every reference cycle, is linear in regard to the phase



### 5.3. SYNTHESIZER UNIT (MODULE 3) cont.:

difference between the reference signal and the signal from the programmable divider. In this period the output voltage has to be sampled and held and this is done by the sample & hold circuit, consisting of U19, R64, C95, Q19, and R77.

Q19 functions as the switch, which carries out the sampling. The switch is open when the gate voltage is at low state and vice versa.

C95 is charged to the phase detector voltage through R77 when the sample switch is closed, and carries out the hold function when the sample switch is open.

The voltage on C95 is led to the active loop filter through the voltage follower U19.

#### **CURRENT MIRROR**

The current mirror is built-up around transistor array U20 and the circuit generates reference current for the phase detector and the API-circuit.

The current mirror is so designed that the ratio between reference current for phase detector and API-circuit respectively will be kept as a constant regardless of the temperature. A change in one of the currents will be reflected or mirrored into the other.

The nominal value of reference current for the API circuit can be adjusted by means of potentiometer R88.

#### **CONTROL SIGNAL LOGIC**

The circuit is built-up around one 8-bit counter U32, which is clocked by the input signal to the reference divider. The clock frequency is 5.36576 MHz.

The counter is reset by the output signal from the reference divider.

The control logic delivers reset signal to the ramp generator and sample signal for the sample & hold circuit. The output signals from the circuit are generated through detection of which state the 8-bit counter is in, and the detection is done by means of the logical circuitry formed by U25 and U29.

#### **API CIRCUIT**

The circuit delivers signal to the modulus control logic and correction signal (API voltage) for the phase detector. The circuit is built-up around a 12-bit digital accumulator constituted by U2, U3, U4, U7, U8, U9, and U12 containing a fraction register, a binary adder, and a sum latch.

Overflow information from the binary adder is led to the modulus control logic and implies a change in the integer number dividing figure in one reference cycle.

In every reference cycle the contents of the accumulator is renewed by clocking the sum latch, the clocking is controlled by the control logic circuit.

The output from the binary adder is led to a 12-bit D/A converter U14, which in connection with OP. AMP U18 generates the API voltage.

The reference current to the D/A converter is derived from the reference current to the phase detector by means of the current mirror and is led through the current switch and current buffer & filter to the D/A converter. D11, D12, Q16, and Q15 constitute the current switch, which adjusts the mean value of the reference current to the D/A converter as a function of the integer number dividing figure in the loop.

### 5.3. SYNTHESIZER UNIT (MODULE 3) cont.:

When the signal on basis of Q15 is at high state, D11 is switched on and D12 off and vice versa, and by changing the duty cycle of a square wave signal on basis of Q15 the mean value of the current to the D/A converter can be adjusted.

Control of the current switch is carried out by the 1/N correction logic, which as a function of the output from the programmable divider and the output from the prescaler produces a square wave signal measurable on U13 pin 13 where the duty cycle is varied as function of the integer number loop dividing figure so that the duty cycle increases for decreasing VCO frequency and vice versa.

From the current switch the current is led to buffer & filter constituted by Q14, C84, and C85, which buffers and filters out the reference current to the D/A converter.

#### MODULUS CONTROL LOGIC

The modulus control logic is constituted by U28 and U23, which as a function of overflow signal from the accumulator, prescaler output, modulus control signal from the programmable divider and output from the 1/N correction logic, generates modulus control signal for the prescaler.

The circuit does not effect the modulus control signal from the programmable divider when the loop dividing figure includes a fraction part, the prescaler modulus shall be changed in one prescaler output period from 32 to 33, if there is a reference cycle where overflow signal is given from the digital accumulator. This change of prescaler modulus implies the needed change of dividing figure to increase the mean frequency of the VCO with a fraction of the reference frequency, and the change is timed through the modulus control logic.

#### DIVIDER CIRCUITS

The programmable divider consists of a dual modulus prescaler U22 dividing by 32/33 and a programmable divider included in U24. The integer number dividing figure is latched into U24.

The reference divider consists of a D-FF U31 followed by the programmable reference divider U30.

The division ratio of U31 is 2 and the division ratio of U30 is 131. This implies a total division ratio of 262.

#### BUFFER CIRCUITS

The VCO signal is led from the VCO buffer into L01 buffer and prescaler buffer.

The L01 buffer consists of Q17 and Q22 and the buffer generates the necessary power level for both receiver and exciter modules.

The output of the buffer is led to relay RE01, which feeds the signal to receiver and exciter respectively, dependent upon whether the transceiver is in transmit or receive mode.

The control of RE01 is carried out by serial to parallel register.

The prescaler buffer consists of Q18 and Q21 and the major task of the circuit is to prevent spurious signals created in the prescaler from being added to the VCO signal and through that imply spectral impurity of the L01 signal.

The TCX0 signal is led to the TCX0 buffer, which consists of Q27 and Q26.

The buffer delivers signal for the reference divider and carrier reinjection signal for both receiver and exciter modules.

### 5.3. SYNTHESIZER UNIT (MODULE 3) cont.:

#### PHASE LOCKED LOOP 2

The change between transmitted and received upper and lower sideband is generated by a frequency change in PLL2 as illustrated below.

#### USB Receiver

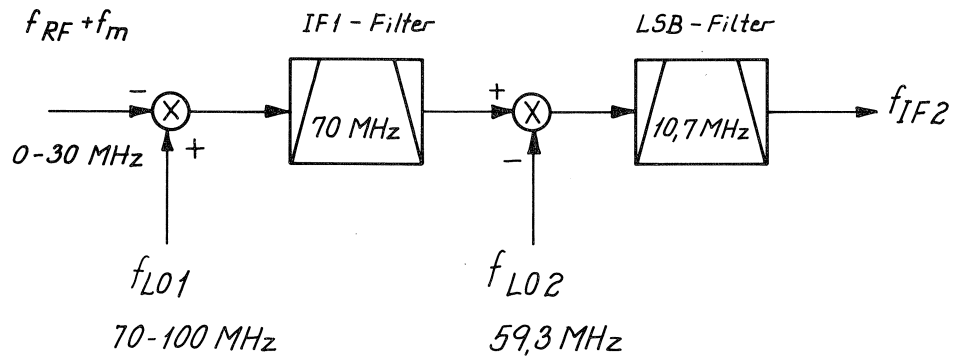

$f_m$  = Modulation frequency  
 $f_{IF2} = f_{L01} - f_{L02} - f_{RF} - f_m$

The modulation frequency  $f_m$  changes sign meaning that a received upper sideband signal will pass through the 10.7 MHz lower sideband IF-filter.

#### LSB Receiver

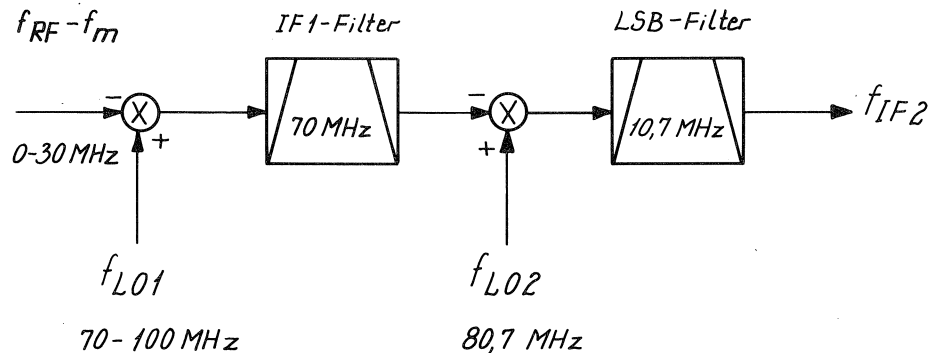

$f_m$  = Modulation frequency  
 $f_{IF2} = f_{L02} - f_{L01} + (f_{RF} - f_m)$

The modulation frequency  $f_m$  does not change sign meaning that a received lower sideband signal will pass through the 10.7 MHz lower sideband IF filter.

### 5.3. SYNTHESIZER UNIT (MODULE 3) cont.:

#### Block Diagram of USB/LSB Synthesizer

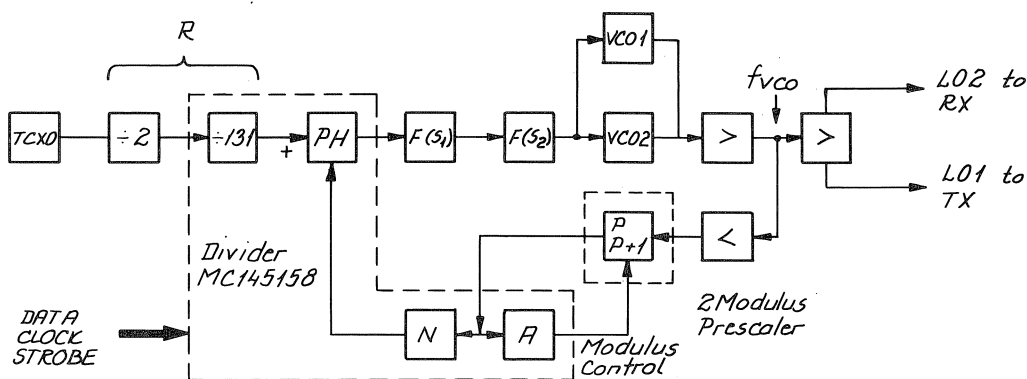

From the block diagram it can be shown that the output frequency  $f_{VCO}$  has the following function of  $f_{TCXO}$ :

$$f_{VCO} = f_{TCXO} \frac{1}{R} (N \cdot P + A) \quad P \text{ chosen to } 32.$$

$$f_{TCXO} = 10.73152 \text{ MHz}$$

When upper sideband is chosen the following counts are read into the divider U35.  $R = 2 \times 131$ ,  $N = 45$ ,  $A = 7$ , this gives  $N \cdot P + A = 1447$  and the lock frequency is  $f_{VCO} = 59,269.120 \text{ MHz}$ .

When lower sideband is chosen the following counts are read into the divider U35.  $R = 2 \times 131$ ,  $N = 61$ ,  $A = 19$ , this gives  $N \cdot P + A = 1971$  and the lock frequency is  $f_{VCO} = 80,732.160 \text{ MHz}$ .

#### VOLTAGE CONTROLLED OSCILLATOR

The circuit contains two similar VCO's. One is active in LSB mode and the other is active in USB mode.

The oscillator which is active in the LSB mode is built around the transistor Q30. Coil L31, paralleled with C130 and C129 in combination with the variable capacitor D19 form the main part of the frequency determining elements.

D20 and R120 which are connected to the gate of the oscillator transistor prevent the gate source voltage from becoming positive which will cause the oscillator noise to increase.

To activate the oscillator U01 - pin Qg is "LOW" which means that transistor Q28 is off and the transistors Q29, Q31 are on supplying the oscillator transistor with DC voltage.

The oscillator which is active in the USB mode is built around the transistor Q33. Coil L37 parallel with C150 and C149 in combination with the variable capacitor D22 form the main part of the frequency determining elements.

## 5.3. SYNTHESIZER UNIT (MODULE 3) cont.:

D23 and R133 which are connected to the gate of the oscillator transistor prevent the gate source voltage from becoming positive which will cause the oscillator noise to increase.

To activate the oscillator U01. Pin Qg is "high" which means that the transistors Q32 and Q35 are on supplying the oscillator transistor with DC voltage.

When one oscillator is supplied with DC voltage the other is off.

The DC supply to the oscillator switches the diode D21 or D24 on and thereby supplies DC voltage to the oscillator buffer transistor Q36. From this transistor the local oscillator signal is fed to the prescaler buffer and to the output local oscillator buffer.

**PRESCALER BUFFER**

From the oscillator buffer transistor Q36 the signal is fed through the network consisting of R159 and C180 to the grounded basis transistor Q38. The local oscillator signal is amplified here and fed through the attenuator R168/R170 and the amplifier transistor Q40. The result is an amplitude stabilized signal which is fed to the prescaler U36.

**PRESCALER AND DIVIDER**

The programmable divider consists of a dual modulus divider U36, dividing by 32/33 and a programmable divider included in U35.

The division ratio is determined by the number latched into U35 and together with U36 the divider works as a conventional dual modulus divider with the modulus control from U35 controlling the prescaler U36.

The reference frequency divider is included in U35.

The reference frequency input on pin 1 has the frequency 5,365.760 MHz and the reference division ratio R read into U35 is 131 leading to a reference frequency of 40.96 kHz which can be monitored on pin 13. This 40.96 kHz signal is used as the reference signal to the phase detector. The variable frequency to the phase detector is the VCO frequency divided with the read in "division ratio". This ratio is 1447 when USB mode is chosen, and by LSB mode 1971 leading to the two phase lock frequencies in USB of 59,269.120 MHz and in LSB mode 80,732.160 MHz.

**PHASE DETECTOR AND LOOP FILTER**

The phase detector is an integrated part of U35. The input reference frequency  $f_R$  is 40.96 kHz which can be monitored on pin 13 and the input variable frequency  $f_V$  can be monitored on pin 3. The three-state output of the phase detector produces a loop error signal which is used with the loop filter to control the VCO. The phase detector output is for frequency  $f_V > f_R$  or  $f_V$  leading, negative pulses. For frequency  $f_V < f_R$  or  $f_V$  lagging, positive pulses and for  $f_V = f_R$  and phase coincidence, the output is in high impedance state.

The loop filter consists of two parts. The first part of the loop filter built around the amplifier U34 and the R/C network R118 and C131 take care of the loop characteristic. The second part of the filter consisting of L34, L35 and C141/C143/C146 is a passive lowpass filter which removes the remaining part of the 40.96 kHz reference signal from the VCO control signal.

## 5.3. SYNTHESIZER UNIT (MODULE 3) cont.:

**OUTPUT LOCAL OSCILLATOR BUFFER**

From the oscillator buffer transistor Q36 the VCO signal is amplified in transistor Q34 and filtered in the lowpass filter consisting of C176, L40, and C177. Before the signal is fed to the output terminal it is amplified in transistor Q37 and fed through the relay RE2.

When the relay is activated the VCO signal is fed into the first mixer on the transmitter module. The diode D26 is conducting and thereby grounding the remaining part of the signal to the receiver module. When the relay RE2 is not activated the diode D26 is reversed and the VCO signal is fed to second mixer on the receiver module.

**SYNTHESIZER WAVEFORMS**

The below waveforms are identified with a signal name, which can be found in the diagram of the synthesizer module (3).

**TEST CONDITIONS**

Frequency setting  $f_{RX} = 2058.24 \text{ kHz}$   
Mode = J3E/USB

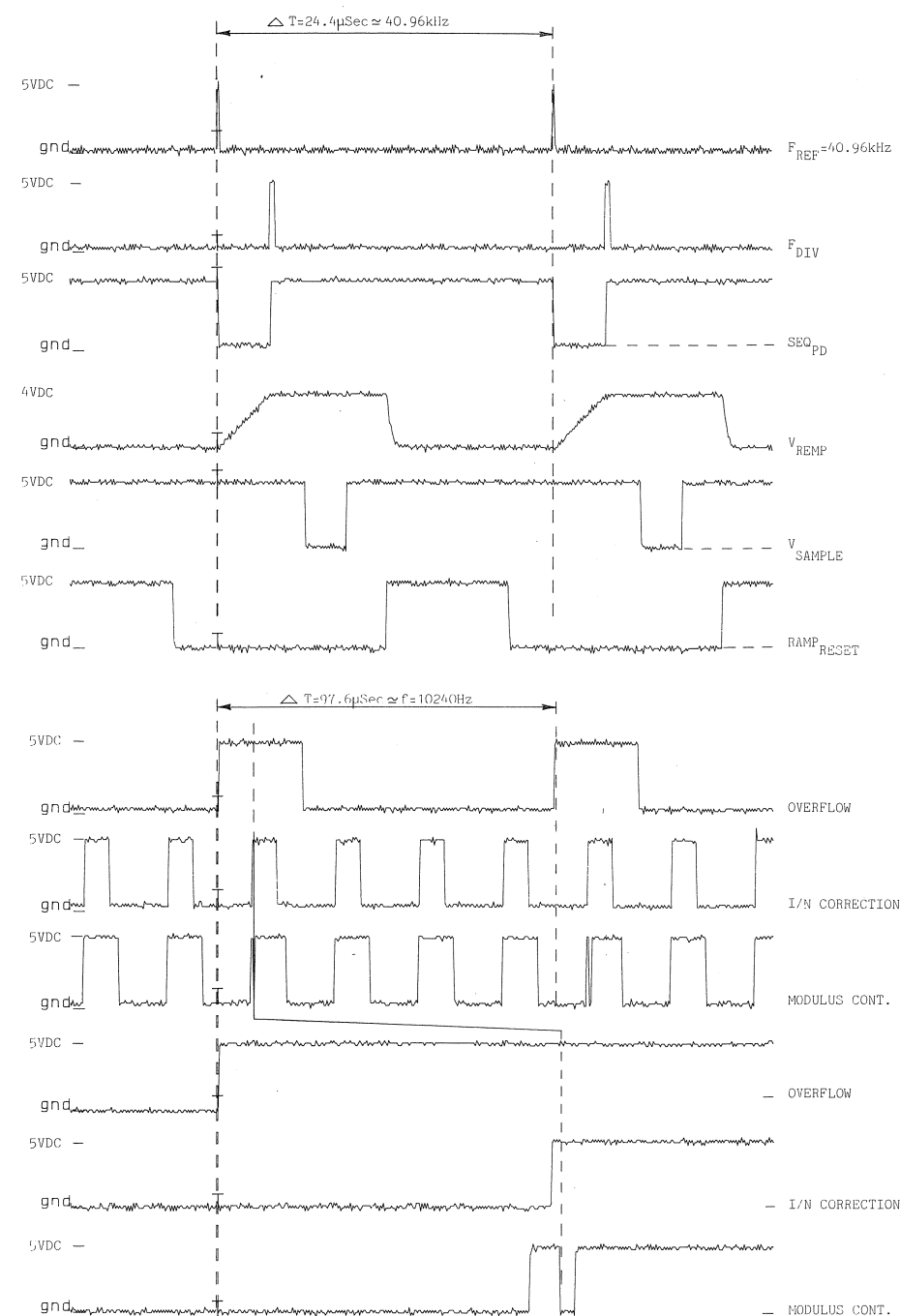

ION SYNTHESIZER UNIT (MODULE 3)

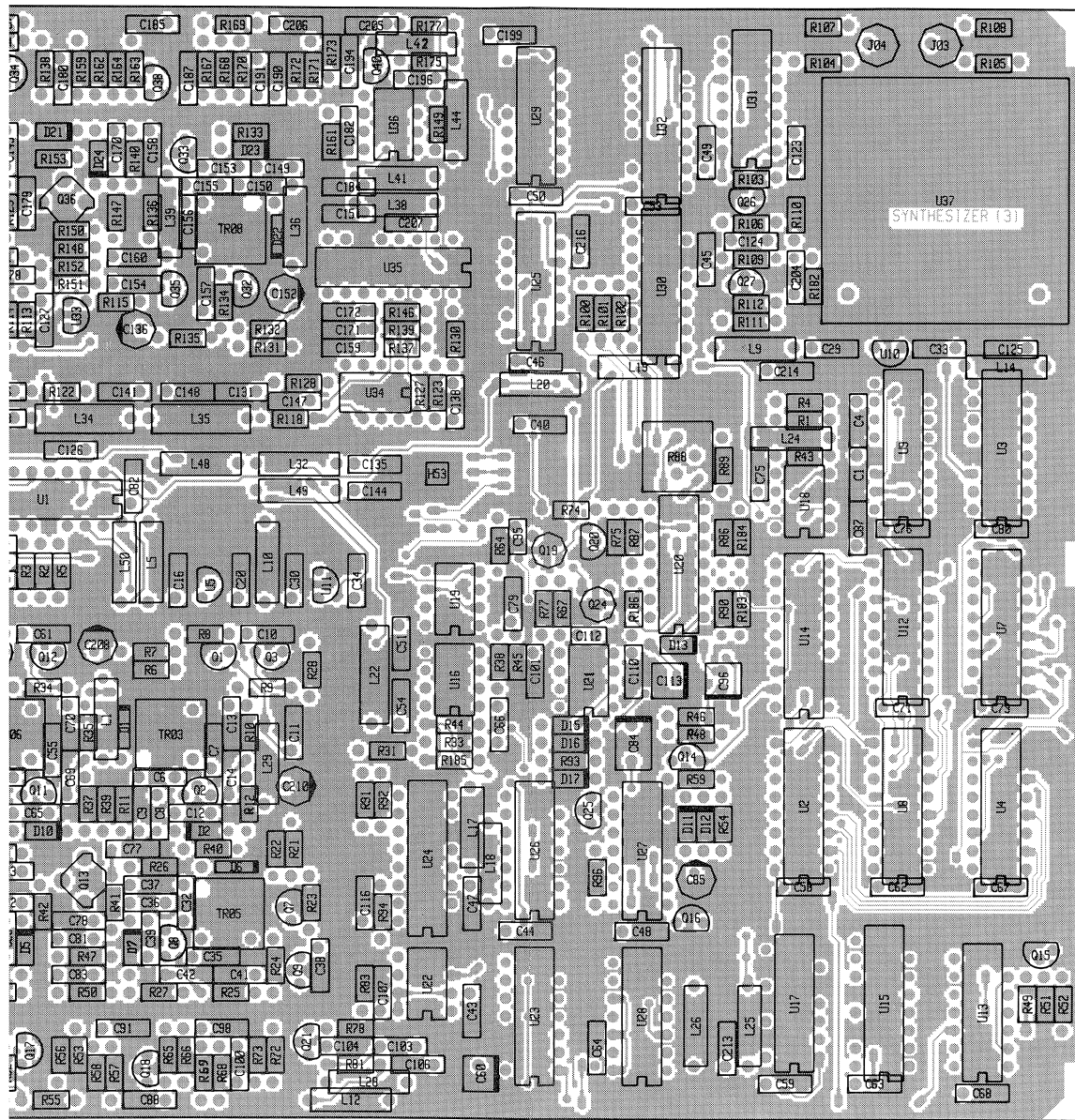

with upper side tracks.

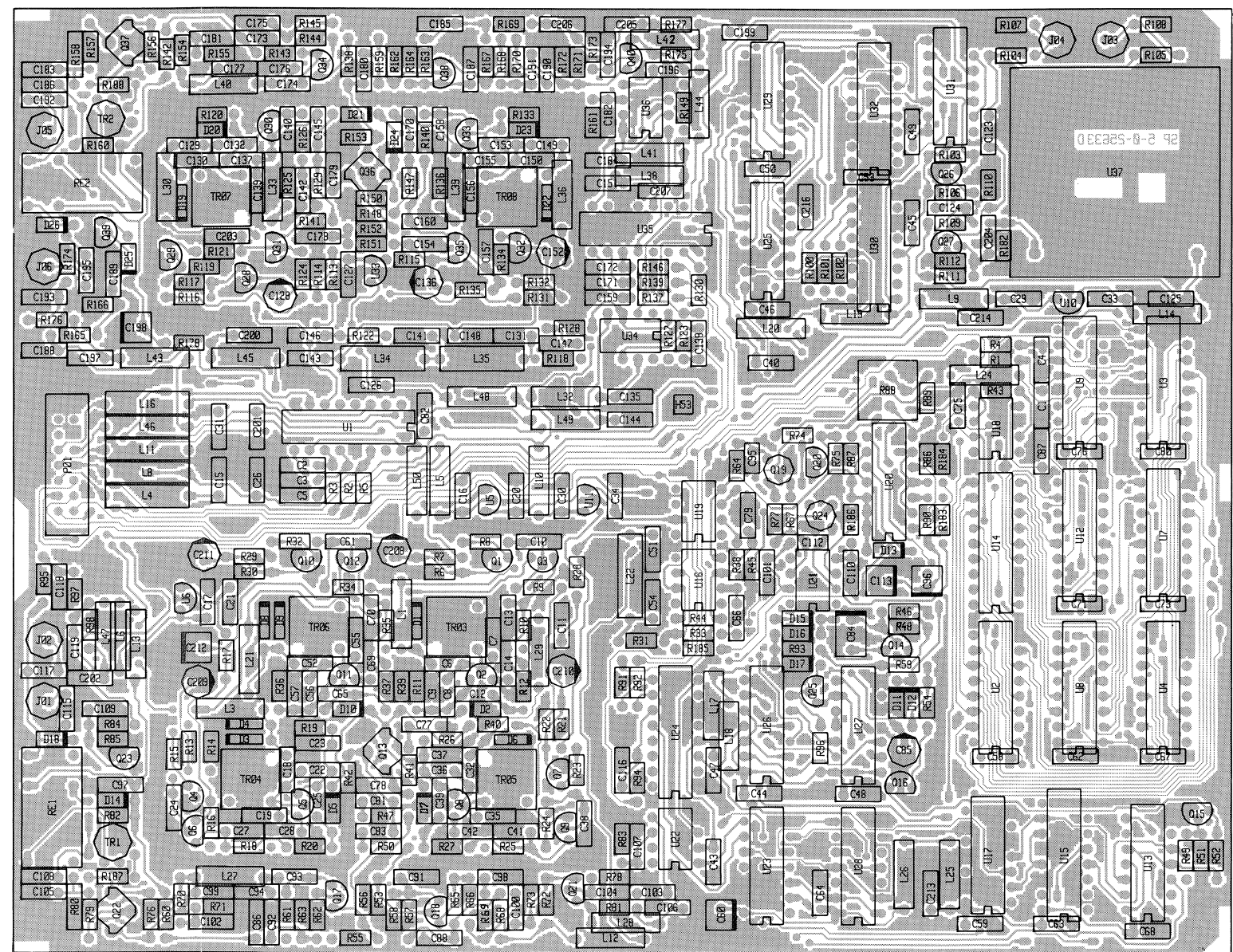

Seen from component side with lower side tracks.

**RESIZER UNIT (MODULE 3) cont.:**

133 which are connected to the gate of the oscillator transistor. The gate source voltage from becoming positive which will cause transistor noise to increase.

the oscillator U01. Pin Qg is "high" which means that the transistors Q32 and Q35 are on supplying the oscillator transistor with

the oscillator is supplied with DC voltage the other is off.

Apply to the oscillator switches the diode D21 or D24 on and thereby apply DC voltage to the oscillator buffer transistor Q36. From this the local oscillator signal is fed to the prescaler buffer and the output local oscillator buffer.

**BUFFER**

the oscillator buffer transistor Q36 the signal is fed through the network consisting of R159 and C180 to the grounded basis transistor Q38. The oscillator signal is amplified here and fed through the attenuator network and the amplifier transistor Q40. The result is an amplified local oscillator signal which is fed to the prescaler U36.

**PHASE LOCK AND DIVIDER**

The phase lock divider consists of a dual modulus divider U36, dividing the reference frequency and a programmable divider included in U35.

The division ratio is determined by the number latched into U35 and together with the divider works as a conventional dual modulus divider with digital control from U35 controlling the prescaler U36.

A reference frequency divider is included in U35.

The reference frequency input on pin 1 has the frequency 5,365.760 MHz and the reference frequency division ratio R read into U35 is 131 leading to a reference frequency of 40.96 kHz which can be monitored on pin 13. This reference signal is used as the reference signal to the phase detector.

The reference frequency to the phase detector is the VCO frequency divided by the division ratio. This ratio is 1447 when USB mode is used and by LSB mode 1971 leading to the two phase lock frequencies 59,269.120 MHz and in LSB mode 80,732.160 MHz.

**PHASE DETECTOR AND LOOP FILTER**

The phase detector is an integrated part of U35. The input reference frequency  $f_R$  is 40.96 kHz which can be monitored on pin 13 and the input frequency  $f_V$  can be monitored on pin 3. The three-state output of the phase detector produces a loop error signal which is used with the loop filter to control the VCO. The phase detector output is for  $f_V > f_R$  or  $f_V$  leading, negative pulses. For frequency  $f_V < f_R$  or lagging, positive pulses and for  $f_V = f_R$  and phase coincidence, the output is in high impedance state.

The loop filter consists of two parts. The first part of the loop filter consists of the amplifier U34 and the R/C network R118 and C131 take the loop characteristic. The second part of the filter consisting of the network R118 and C131 and a passive lowpass filter which removes the remaining part of the 40.96 kHz reference signal from the VCO control

**5.3. SYNTHESIZER UNIT (MODULE 3) cont.:**

**OUTPUT LOCAL OSCILLATOR BUFFER**

From the oscillator buffer transistor Q36 the VCO signal is amplified in transistor Q34 and filtered in the lowpass filter consisting of C176, L40, and C177. Before the signal is fed to the output terminal it is amplified in transistor Q37 and fed through the relay RE2.

When the relay is activated the VCO signal is fed into the first mixer on the transmitter module. The diode D26 is conducting and thereby grounding the remaining part of the signal to the receiver module. When the relay RE2 is not activated the diode D26 is reversed and the VCO signal is fed to second mixer on the receiver module.

**SYNTHESIZER WAVEFORMS**

The below waveforms are identified with a signal name, which can be found in the diagram of the synthesizer module (3).

**TEST CONDITIONS**

Frequency setting  $f_{RX} = 2058.24 \text{ kHz}$   
Mode = J3E/USB

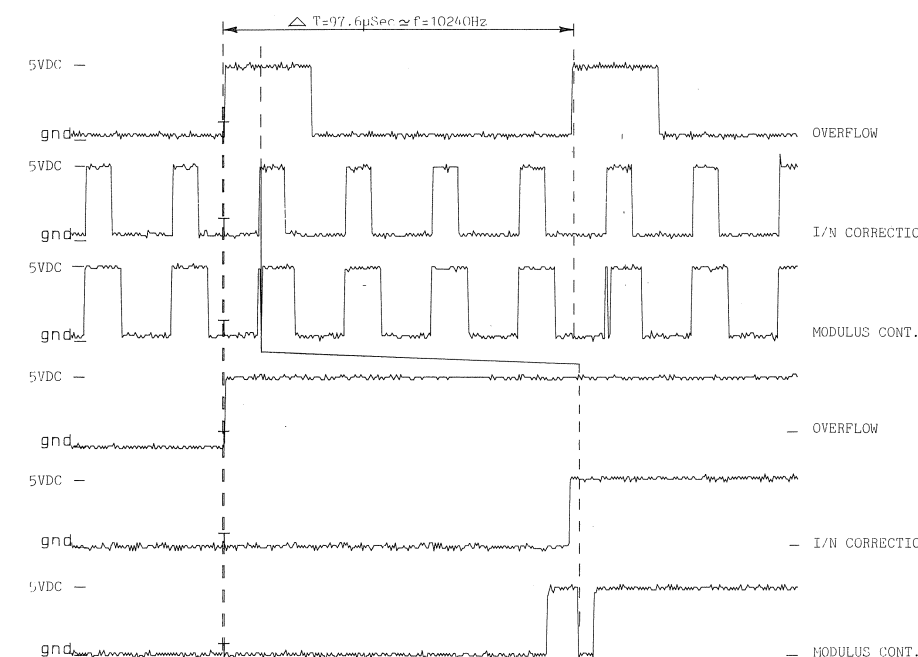
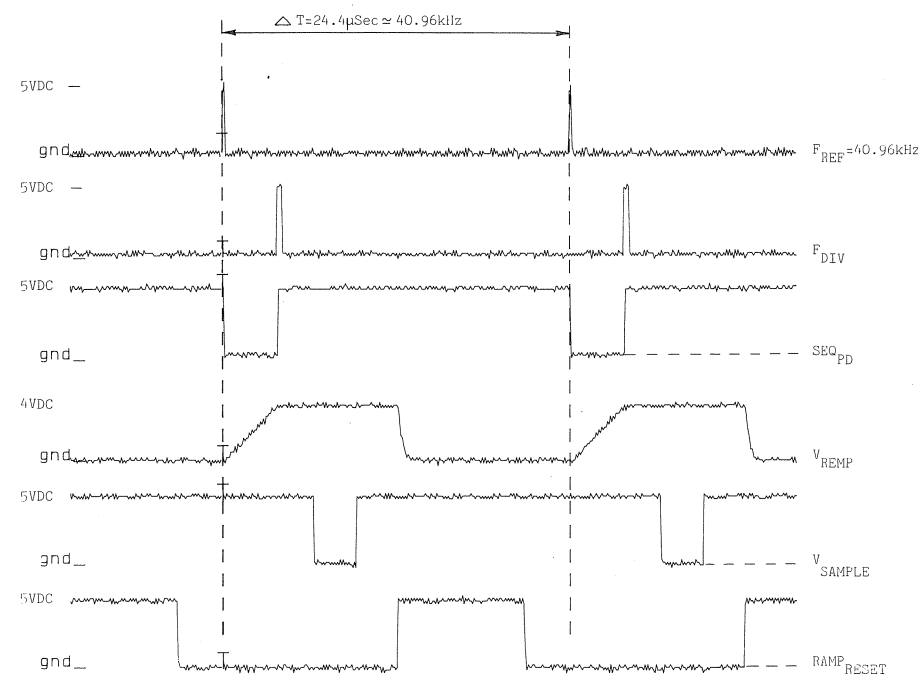

### 5.3. COMPONENT LOCATION SYNTHESIZER UNIT (MODULE 3)

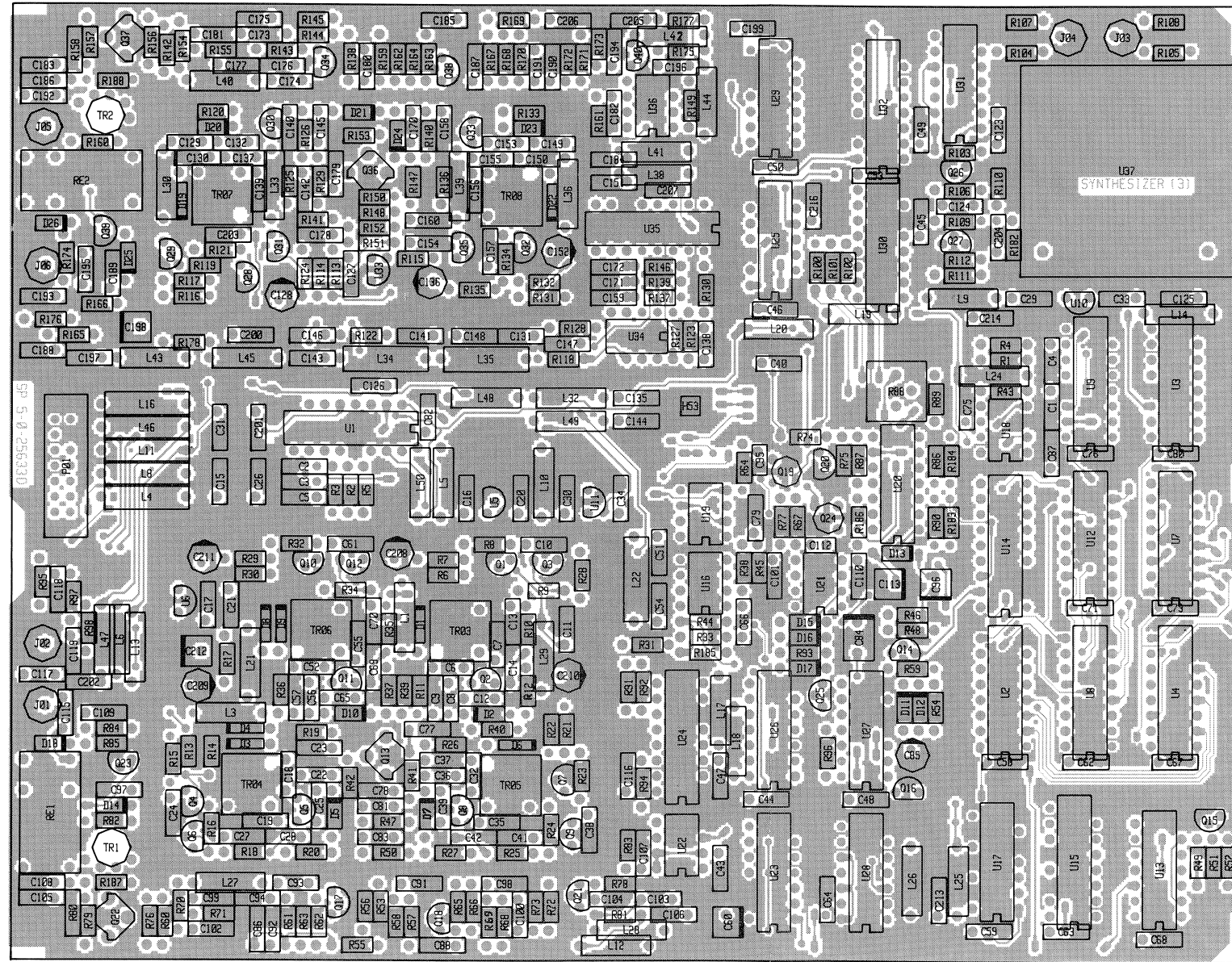

Seen from component side with upper side tracks.

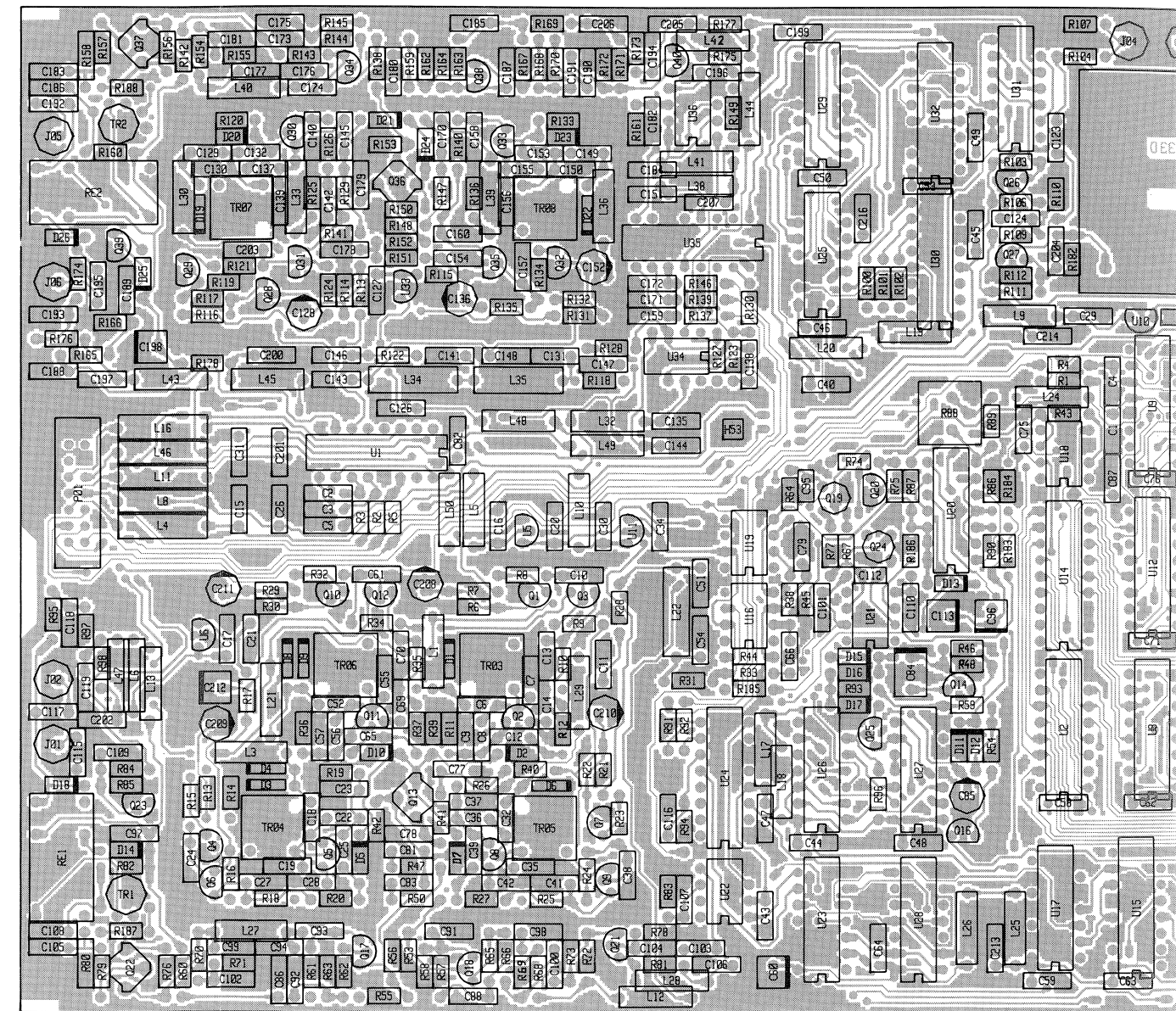

Seen from component side with lower side tracks.







# Synthesizer Unit (3)

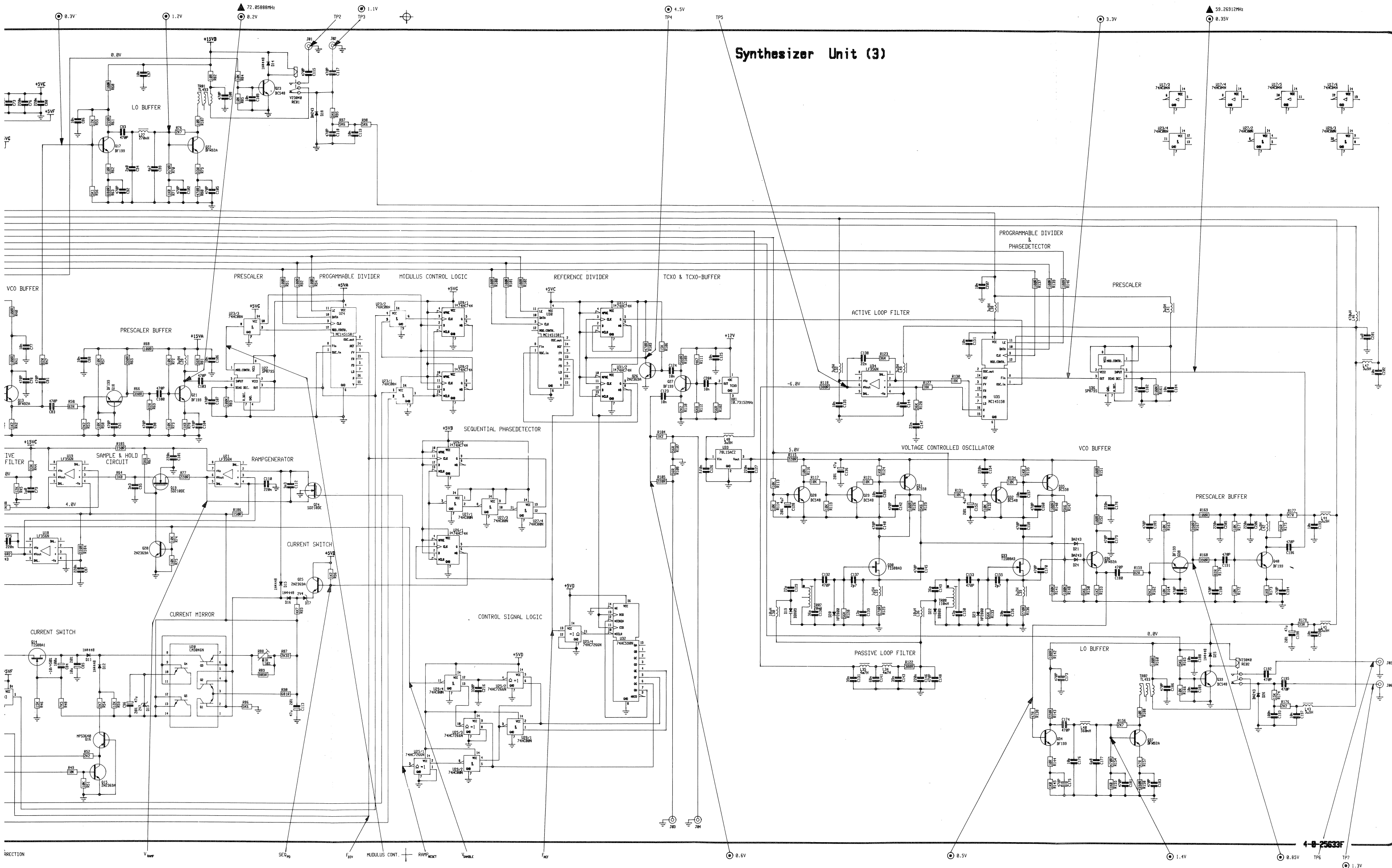



## 5.4. EXCITER UNIT (MODULE 4)

The exciter module is modulating an audio frequency into a carrier frequency. After some amplification and filtration the modulated signal is led to the power unit (module 8) for further amplification and filtration.

### AF SELECTOR

The exciter unit is able to handle three kinds of AF signals: the microphone signal, the tune/alarm tones, and some telex signals. The wanted signal is selected by the analog switch U01, which is switched on by means of the OP-amp. U03. To select the microphone input, the microprocessor sends an 8-bit signal to the shift register U07, which controls the analog switch U01/2 by means of U03/4. The other two AF inputs can be selected in the same way.

From U01 the AF signal is led to the amplifier U02 and through C10 to the compressor circuit. To handle the AF signal the analog switch U01 and the OP-amp. U02 are biased with R04.

### COMPRESSOR AND AF LIMITER

The audio signal from the amplifier U02 is attenuated by means of R20 and the FET Q01. A DC voltage applied to the gate of Q01 controls the attenuation.

From the amplifier U04/1 the audio signal is split into two ways. One way to the AF limiter and another way to a dual rectifier. The rectified audio pulses are compared to a DC level determined by means of D02 and R35. A strong audio signal creates new pulses out of the comparator amplifier U04/2 and into C25, which gives a DC voltage to the gate circuit of Q01.

If the audio signal is so quick and strong that the compressor is unable to handle it, the transistors Q02, Q03, and Q04 cut the peaks of the signal. The cutting symmetry is adjusted with R57.

### CARRIER LIMITER AMPLIFIER

To ensure a constant carrier level to the modulator U05, the transistor Q05 works as an amplitude limiter. The carrier input signal from the synthesizer unit is amplified in Q06. The transistor Q07 controls the bias voltage of Q05 and Q06. To switch on the carrier signal to the modulator, the transistor Q07 is switched on by means of U07 or by an external wire connected to pin 19 on plug P01.

### MODULATOR

The carrier signal from the carrier limiter amplifier Q05 is applied to the modulator U06 pin 10. The audio signal from the AF limiter Q04 is applied to U06 pin 1. The audio signal is multiplied by the carrier signal in U06, and the resulting modulated signals on pin 12 and pin 6 are added in the transformer TR01. The output from TR01 is a double sideband signal with suppressed carrier. With R190 the carrier suppression can be adjusted.

## 5.4. EXCITER UNIT (MODULE 4) cont.:

### MODULATION LEVEL AMPLIFIER

The modulated signal is led to the voltage divider R77, R78, and R85. The mode selector circuit is forward biasing one of the diodes D10, D11, or D12 to select the wanted modulation level for the modulation mode in question. The wanted modulation level is led to the amplifier Q09, and then to the SSB crystal filter where the unwanted upper sideband is removed. The amplification is adjusted with R87.

### CARRIER LEVEL AMPLIFIER

The carrier signal is led to the voltage divider R95 and R96. The wanted amount of carrier insertion for R3E or H3E mode is selected by one of the diodes D14 or D15 and led to the amplifier Q10. The diodes D14 and D15 are controlled by the mode selector circuit. In the J3E mode no carrier is wanted, and therefore D14 and D15 are reverse biased, while D18 is forward biased to short-circuit any carrier signal for Q10.

### MODE SELECTOR

Only two bits from the shift register U07 (pin 15 and pin 1) are used to control the mode selector U08 to select the right combinations of carrier level and modulation level for the mode in question. The outputs from U08 are forward biasing or reverse biasing the switch diodes in the carrier level amplifier and in the modulation level amplifier.

### CARRIER INSERTION AND RF LIMITER

The SSB signal from the crystal filter FL01 is led to transistor Q11. The wanted amount of carrier signal from transistor Q10 is added to the modulated SSB signal on the collector of Q11. The output from the transformer TR02 is connected to a peak to peak RF limiter network, consisting of the diodes D19 and D20 biased by the zener diode D21. The signal from TR02 is led to the buffer amplifier Q19 at the input to the step attenuator.

### STEP ATTENUATOR AND 1st MIXER

The step attenuator is divided in two parts. Part one consisting of the transistors Q20, Q21, Q22 and Q23 is divided in steps 0.3 dB, and part two, consisting of the transistors Q14, Q15, and Q16 is divided in steps of 4.5 dB.

Part one of the step attenuator is working as a voltage divider, where the SSB signal on the emitter of Q19 is divided by R148 and the parallel connection of the resistors R151, R153, R173, and R175, depending on which one is grounded.

The grounding of the resistors in this attenuator takes place in normal binary code, meaning (0000) is equal to non attenuation and (1111) is equal to full attenuation.

In part two of the attenuator the voltage gain of transistor Q12 will be changed according to the wanted attenuation step. From attenuator step 16, R130 will be grounded, and from attenuator step 48, R113, R140, and R145 will be grounded. The wanted attenuator step is controlled by U09, which converts the received input serial code to an output parallel code which controls the grounding of the transistors in the attenuator.

#### 5.4. EXCITER UNIT (MODULE 4) cont.:

The gain in the amplifier Q12 is adjusted with R120. The potentiometer R159 on the basis of the buffer transistor Q18 is used to adjust the attenuation at step 16 to be 0.3 dB higher than the attenuation at step 15.

The output from Q12 is in U10 mixed with the 1st local oscillator to give an intermediate frequency of 70 MHz. If the local oscillator frequency is 80.7315 MHz, the upper sideband USB is selected. If the local oscillator frequency is 59.2685 MHz, the lower sideband LSB is selected.

#### **70 MHZ IF, 2nd MIXER AND LO BUFFER**

The output from the mixer U10 is led to the tuned amplifier Q13. The 70 MHz IF filter is consisting of two monolithic crystal filters FL02 and FL03. From the filter the signal is led to the amplifier Q17 and to the 2nd mixer U11.

Because the 2nd mixer U11 is a high level mixer, it is necessary to amplify the 2nd local oscillator signal. This is done in the LO buffer amplifier Q24.

5.4. COMPONENT LOCATION EXITER UNIT (MODULE 4)

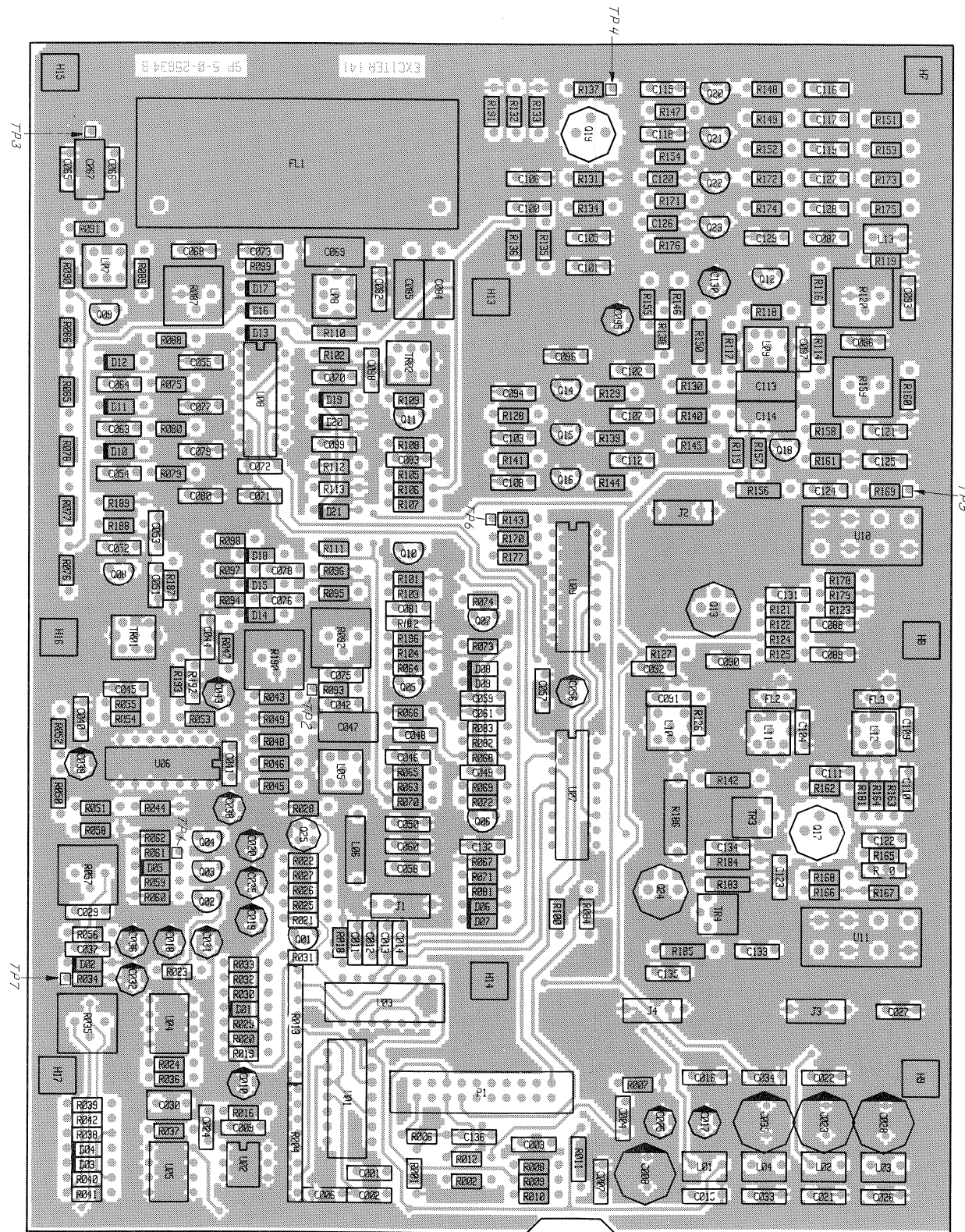

Seen from component side with upper side tracks

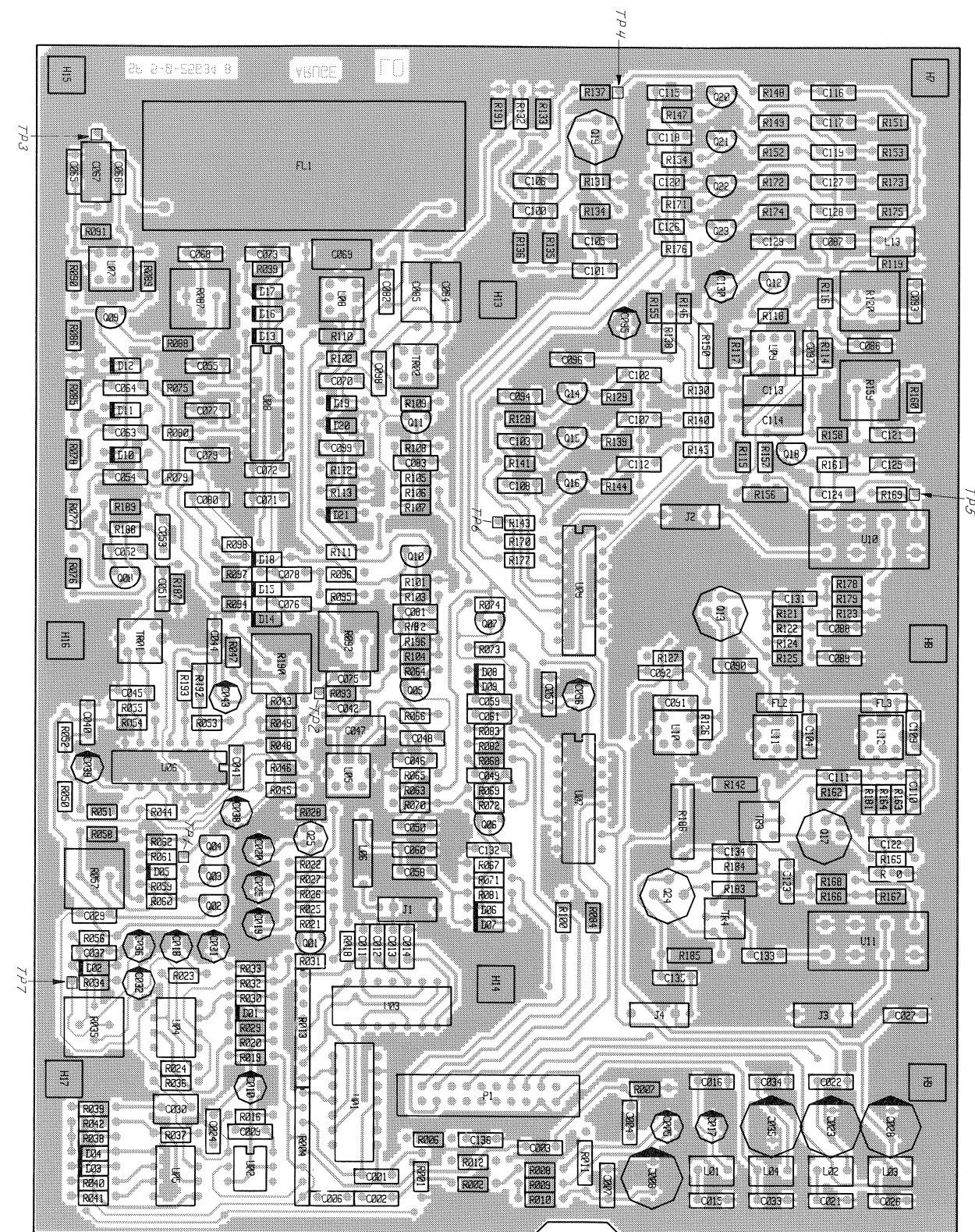

Seen from component side with lower side tracks



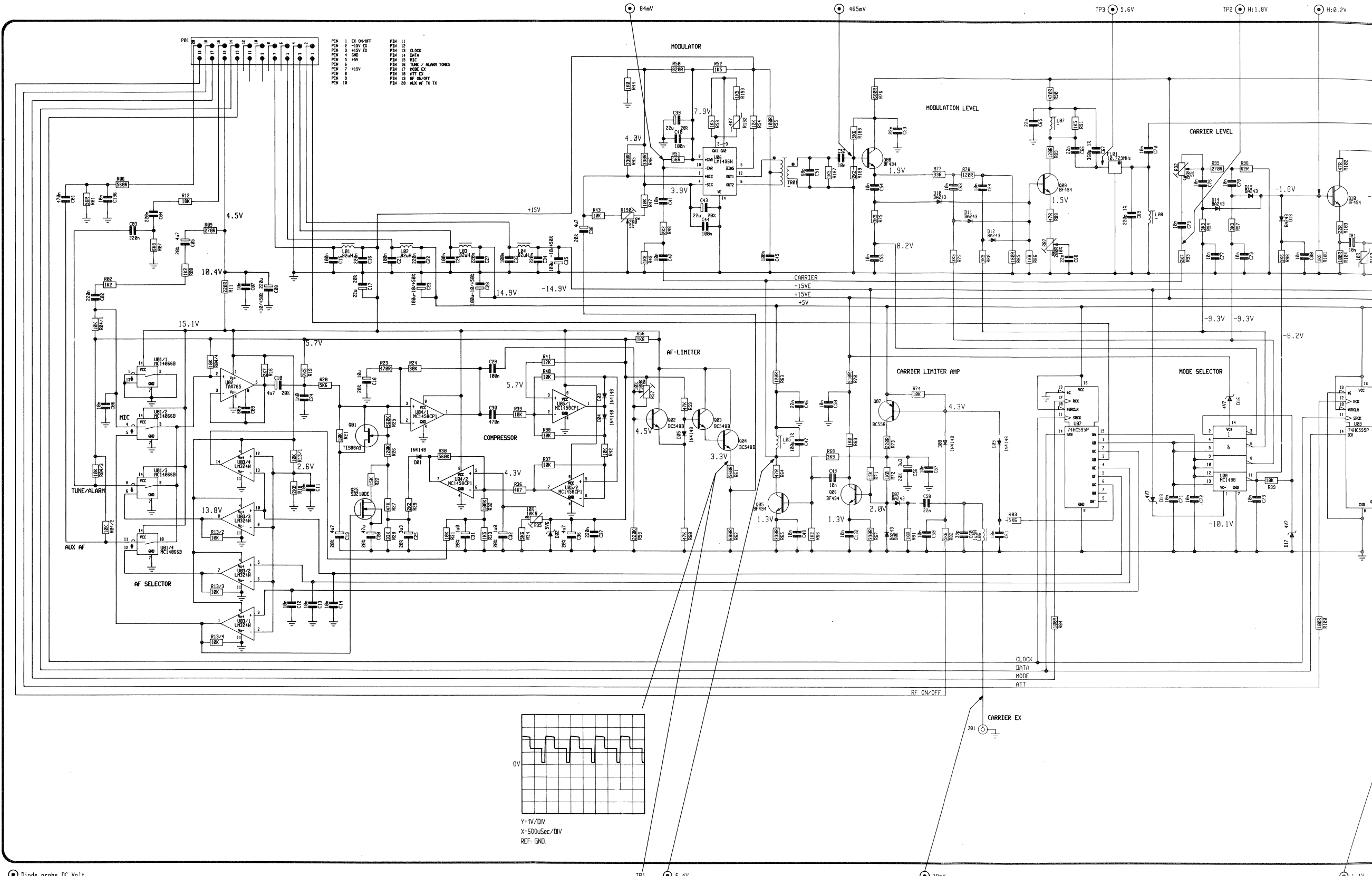

● Diode probe DC Volt  
 Normally: Service programme SP-05-0  
 H: Service programme SP-05-1 and H3E mode







## 5.5. PROCESSOR UNIT (MODULE 5)

The processor module has been built up around a microprocessor of the type HD63B03VP with belonging 8.005 MHz crystal. The purpose of the microprocessor is to control the other modules in the RE2100 by means of a Serial Peripheral Interface Bus (SPI), and to scan the keyboard. Furthermore the processor must also control the Serial Communication Interface Bus (SCI), also called the SP-BUS.

### **MICROPROCESSOR**

The microprocessor module is normally equipped with a ROM less processor, type HD63B03VP, however mass produced types may also occur. The placing of a strap in P02 informs the processor from where to read the programme. If the strap is placed between pin 1 and pin 2, the programme is read from the internal ROM store. If the strap is placed between pin 2 and pin 3, the programme is read from the external store (27C128/27C256). The internal clock frequency of the processor is 2 MHz.

### **WATCH DOG**

The microprocessor supervising circuit U15 works as watch dog and power sense.

In U15, pin 6 (watch dog input) the level must change at least once every 1.6 sec. If not, the U15 generates a reset pulse to the microprocessor.

Power fail input U15, pin 4 detects when the 9V supply falls below 7.0V. In this case, the microprocessor receives an interruption via power fail output U15, pin 5. The programme starts storing data in the EEPROM. This function is used when the receiver is switched off (see the paragraph below: ON BOARD POWER SUPPLY).

When VCC to U15 is below 4.65V the reset output U15, pin 7 goes low, and the U15 does not generate a reset to the microprocessor until the VCC is above 4.75V again.

### **MEMORY**

The microprocessor has two memory circuits. One for programmes and one for data.

The programme memory U06 is a 16 or 32 kbyte PROM, e.g. the type 27C128/27C256 with a max. access time of 250 nS. If 16 kbyte is used, the strap in P01 is mounted between pin 2 and pin 3. When 32 kbyte is used, the strap is mounted between pin 1 and pin 2.

The data memory U05 is an 8 kbyte EEPROM, e.g. the type 28C64 with max. access time of 250 nS. Furthermore it must contain page mode programming of min. 16 kbyte. U15 contains data, such as frequency tables, country versions, scanning tables, and latest set-up after the receiver has been switched off.

### **KEYBOARD**

The keyboard module 6 has been built-up as a 4x8 matrix of which 26 keys are used. The keyboard is scanned by means of 4 ports from the microprocessor and the data bus. When the processor reads from the keyboard, access is made to the bus driver U04.

## 5.5. PROCESSOR UNIT (MODULE 5) cont.:

### EXT. PORT

The Bus Driver U19 acts as an 8-bit input port, which is connected to the internal Data Bus.

### ON BOARD POWER SUPPLY

On this PCB, 3 power supplies are found, i.e. 5VA, 5VB and -5VB.

5VA (U16) supplies the microprocessor, memory, watch dog, baud rate generator, and address select.

5VB (U17) supplies the remaining circuits, using +5V.

-5VB (U18) supplies half of the SP-Bus transmitter.

Power supply 5VA is a low drop 5V regulator. The power supply also works as a power back-up, when the 9V supply disappears. C11 is able to keep the supply for the microprocessor for approx. 50 mS after the 9V supply has disappeared.

The microprocessor spends approx. 20 mS for storing the data in U05. A parallel connection of C14 and C45 has been carried out in order to keep the serial resistance below 1 ohm at low temperatures.

Power supply 5VB is a standard 5V regulator (LM340T5).

### TUNE/ALARM TONE GENERATOR

Tune and alarm tones are generated in the microprocessor and sent out in P26.

Tune tones consist of two simultaneous frequencies of 1000 Hz and 2000 Hz. The microprocessor generates a signal of 2000 Hz. A divider (1/2 U02), enabled by P54, divides the signal to 1000 Hz, and the transistor Q01 adds the two signals before they are passed on to the exciter unit (module 4).

The alarm tones consist of two changing frequencies of 1300 Hz and 2200 Hz. Both tones are generated in the microprocessor. The divider (1/2 U02) will be disabled.

### DISTRESS DRIVER

When a distress frequency (2182 kHz) is selected, the microprocessor port P20 goes high and Q03 will be able to source up to 14 mA. The distress signal is used when connection is made to SAILOR scrambler CRY2001 or CRY2002.

### SERIAL PERIPHERAL INTERFACE BUS (SPI)

The SPI-Bus is a synchronous serial bus supplying the other units with data. The clock speed is 38.5 kHz. Through 4 drivers in U10, the clock and data are passed on to the modules which are connected to the SPI-bus. The strobes for the various modules are generated in SPI address select U09. Through the 4 ports of the microprocessor, P60 - P63, an address is set up, which is suitable for the module which is going to receive the serial data.

### BAUD RATE GENERATOR

The baud rate generator U01 and 1/2 U02 divide the internal clock frequency of 2 MHz by 26 by means of a duty cycle of 50 per cent. The divided frequency is equal to the frequency which must be added to the internal serial communication interface (SCI) of the microprocessor, so that the baud rate of the SP-Bus will be 4800 baud.

## 5.5. PROCESSOR UNIT (MODULE 5) cont.:

### SP-BUS TRANSMITTER AND RECEIVER

The communication from and to the RE2100 is time multiplexed data bus. It is implemented with a 50 ohm coaxial cable, terminated in both ends, and a transmitter and a receiver in each connected unit.

The RE2100 is the master and a number of slaves may be connected to the SP-Bus. When a slave (except from T2130) wants to be called, the slave sends an interrupt to RE2100 on the SP-Bus INTERRUPT. The transmitter and the receiver are identical in each unit connected to the SP-Bus. The transmitter output is normally in high impedance state except when transmitting on the SP-Bus. The transmitter consists of two gates, U13/1 and U13/2 (74HC00), a transistor Q04 (BC558) for level shifting, and two complementary output transistors Q05 (BC640) and Q06 (BC639). The transmitter is connected to the microprocessor P24 (Transmit Data), and P55 (Transmitter Enable).

The receiver consists of an op-amp, (U12/1, MC1458) which is configured as a Schmitt Trigger and two diodes D04 and D11 for level conditioning. The receiver is connected to the microprocessor P23 (Receive Data). As the levels on the SP-Bus approximately match the RS232C standard, it is possible to connect an RS232C to the SP-Bus. The cable terminations (jumper P04) must be removed when the external RS232C is to transmit on the bus.

5.5. COMPONENT LOCATION PROCESSOR UNIT (MODULE 5)

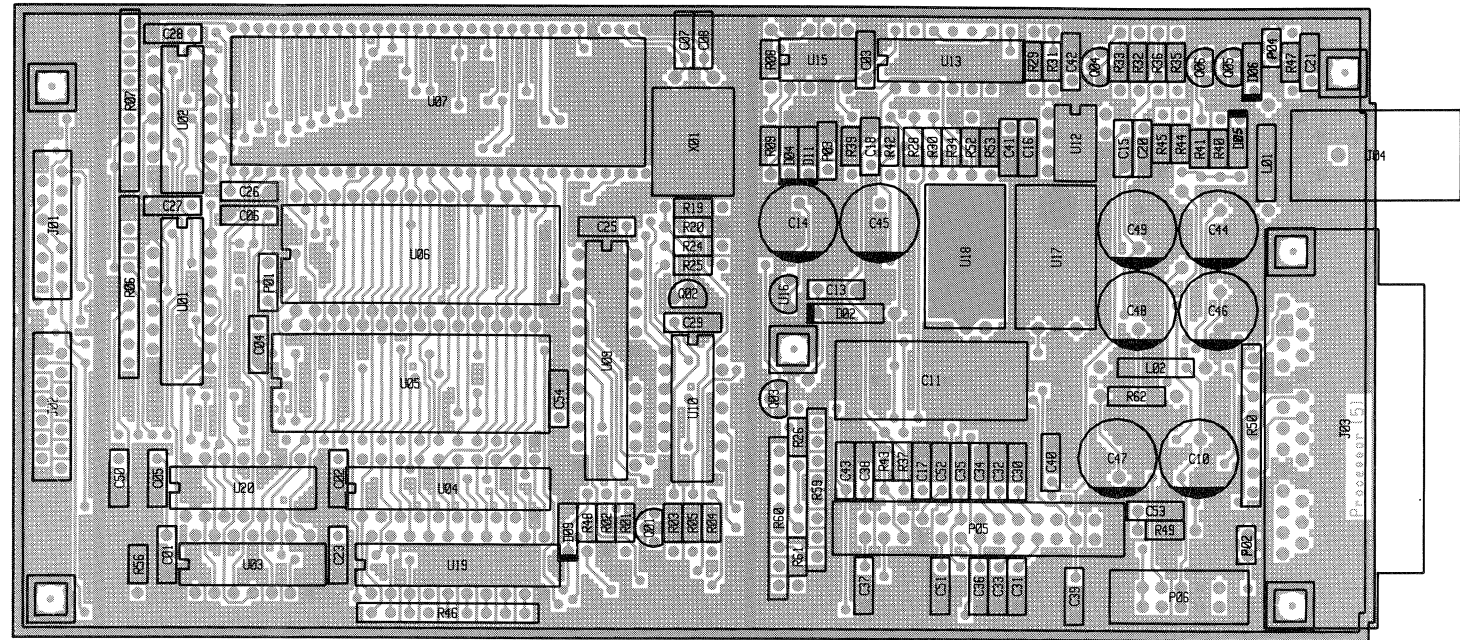

View from component side with upper side tracks.

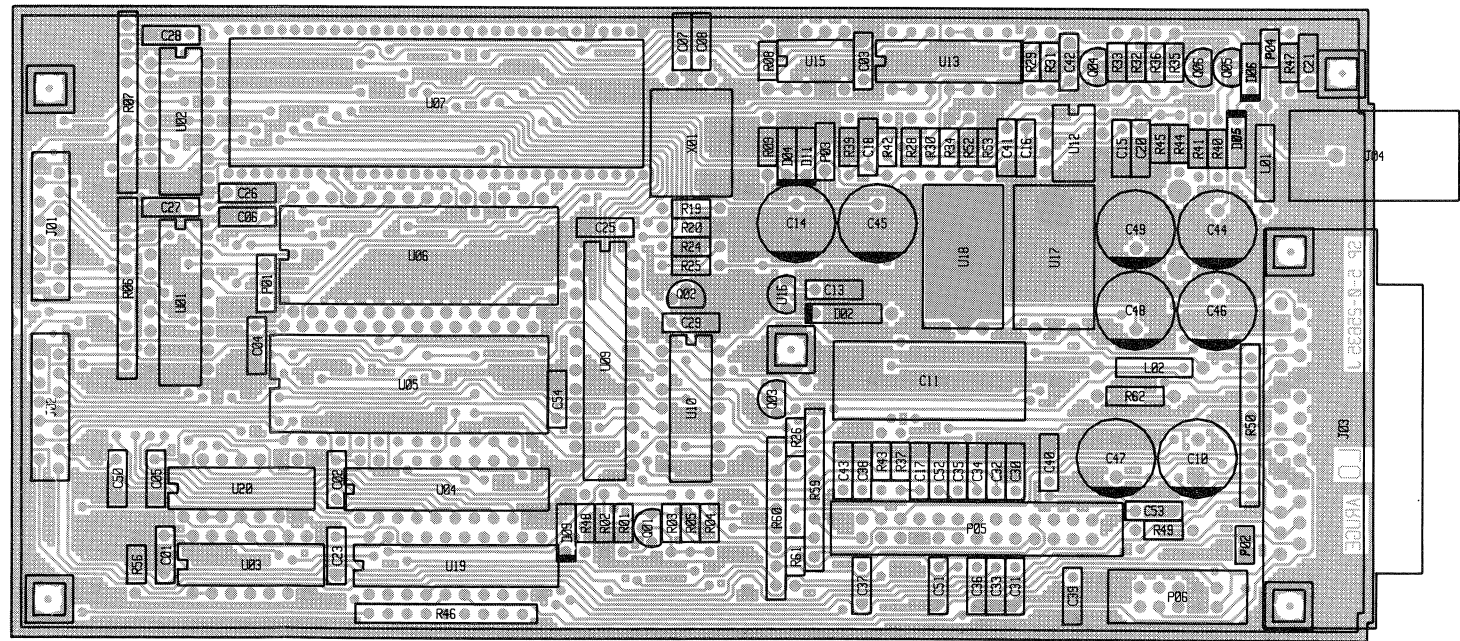

View from component side with lower side tracks.



RE2100 / R2122  
4-0-25635K

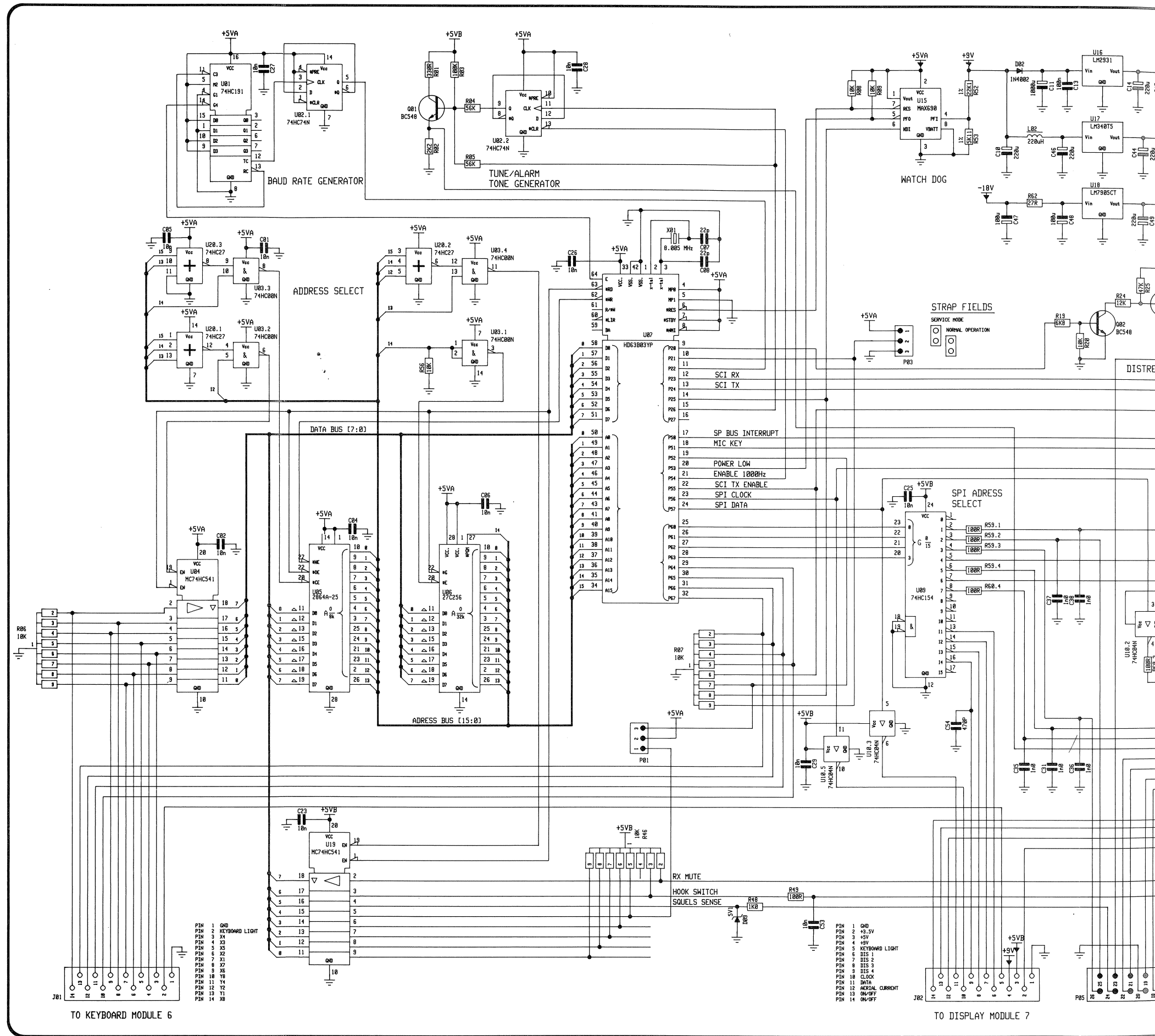



# Processor Unit (5)

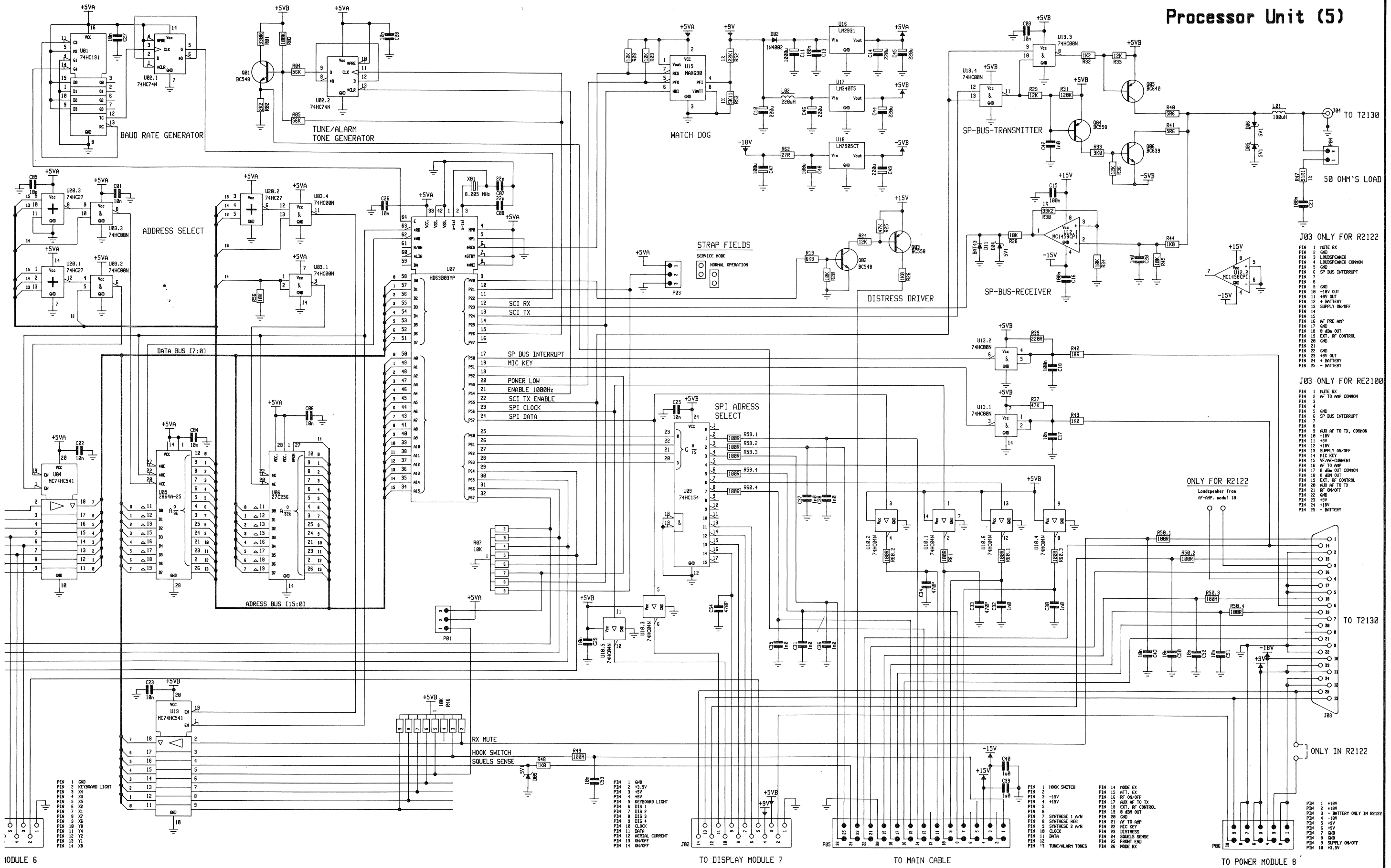

- J03 ONLY FOR R2122**
- PIN 1 MUTE RX
  - PIN 2 GND
  - PIN 3 LOUDSPEAKER COMMON
  - PIN 4 LOUDSPEAKER COMMON
  - PIN 5 SP BUS INTERRUPT
  - PIN 6 GND
  - PIN 7 -18V OUT
  - PIN 8 +5V OUT
  - PIN 9 +5V OUT
  - PIN 10 BATTERY
  - PIN 11 SUPPLY ON/OFF
  - PIN 12 GND
  - PIN 13 AF PRE AMP
  - PIN 14 GND
  - PIN 15 8 OHM OUT COMMON
  - PIN 16 8 OHM OUT
  - PIN 17 EXT. RF CONTROL
  - PIN 18 GND
  - PIN 19 +5V OUT
  - PIN 20 BATTERY
  - PIN 21 GND
  - PIN 22 +5V OUT
  - PIN 23 BATTERY
  - PIN 24 GND
  - PIN 25 - BATTERY

- J03 ONLY FOR RE2100**
- PIN 1 MUTE RX
  - PIN 2 AF TO AMP COMMON
  - PIN 3 GND
  - PIN 4 SP BUS INTERRUPT
  - PIN 5 GND
  - PIN 6 AF AF TO TX, COMMON
  - PIN 7 -18V
  - PIN 8 +5V
  - PIN 9 +5V
  - PIN 10 SUPPLY ON/OFF
  - PIN 11 MIC KEY
  - PIN 12 8 OHM OUT COMMON
  - PIN 13 8 OHM OUT
  - PIN 14 MIC KEY
  - PIN 15 8 OHM OUT COMMON
  - PIN 16 AF TO AMP
  - PIN 17 8 OHM OUT COMMON
  - PIN 18 EXT. RF CONTROL
  - PIN 19 AUX AF TO TX
  - PIN 20 GND
  - PIN 21 RF ON/OFF
  - PIN 22 GND
  - PIN 23 +5V
  - PIN 24 +18V
  - PIN 25 - BATTERY

ONLY FOR R2122

Loudspeaker from AF-APP. modul 18

- ONLY IN R2122**
- PIN 1 +18V
  - PIN 2 +18V
  - PIN 3 - BATTERY ONLY IN R2122
  - PIN 4 -18V
  - PIN 5 +5V
  - PIN 6 +5V
  - PIN 7 GND
  - PIN 8 GND
  - PIN 9 SUPPLY ON/OFF
  - PIN 10 +3.5V



## 5.6. KEYBOARD UNIT (MODULE 6)

The keyboard consists of a 4x8 matrix of which 26 keys are used. One side is connected to the microprocessor data bus by an 8 bit driver. The other side is connected to 4 of the microprocessor ports.

By setting the 4 ports high and reading the data bus alternately it is possible to determine which key has been activated. In this way the keyboard is scanned 100 times per second.

The keyboard light, consisting of 13 LEDs divided in 5 columns, is controlled by an open collector (Q02) on the display print PCB, module 7. The power in each column is approx. 8.5 mA.

### Keyboard Unit (6)

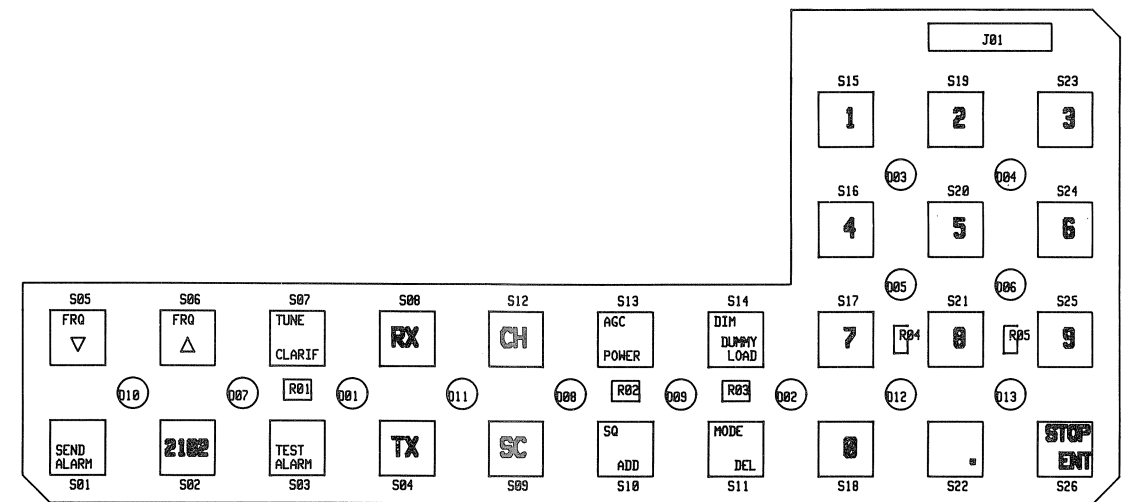
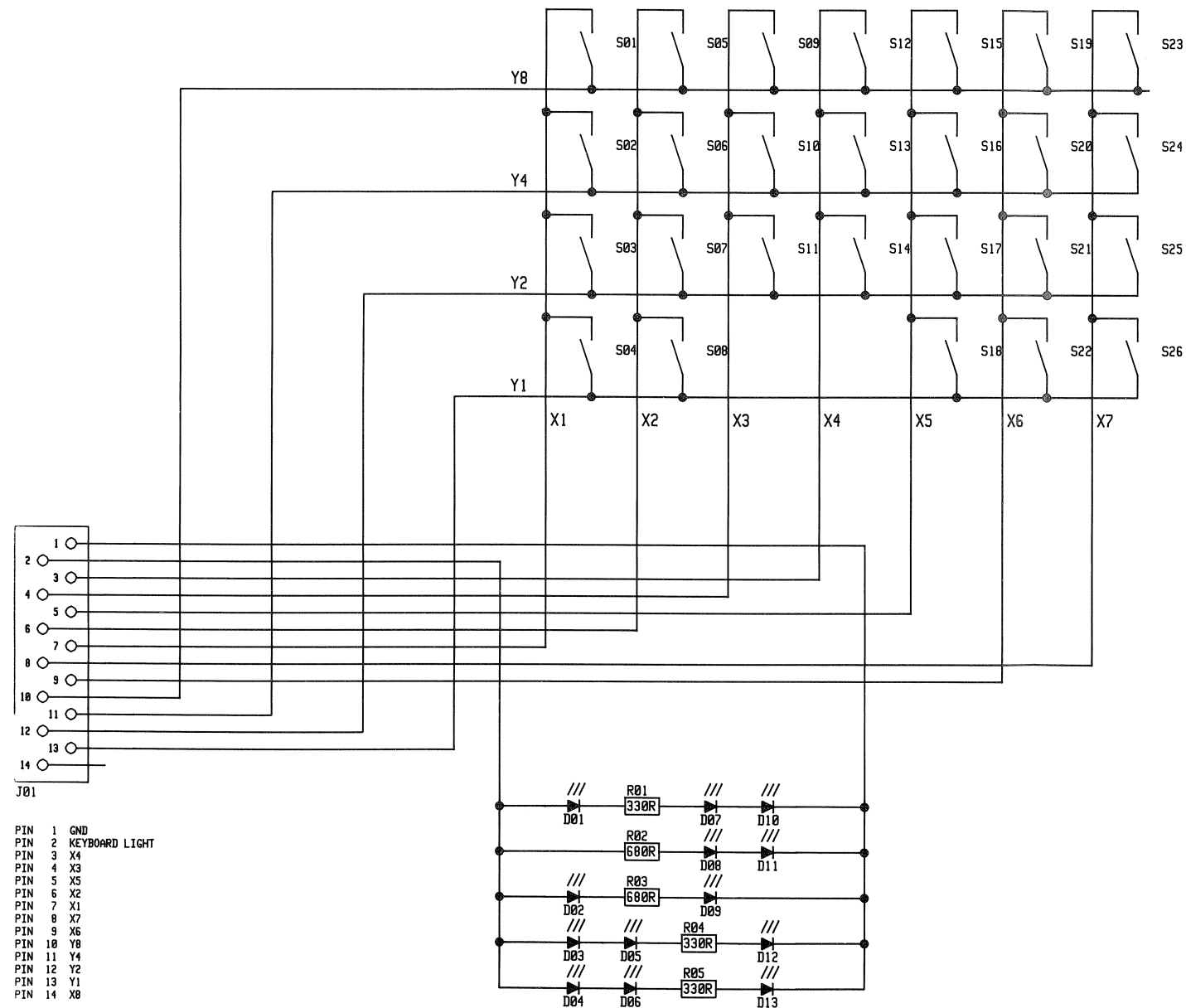

RE2100 4-0-25636C

4-0-25636C



## 5.7. DISPLAY UNIT (MODULE 7)

The display module uses 13 pcs. 7 segments (U08-U20), 12 pcs. LED (D03-D14) and 1 pc. LED-bar (U01) for reading-out information to the operator.

### DISPLAY DRIVER

The display driver U03-U05 is a serial read-in driver, which is able to drive 34 segments. U03, U04, and U05 in combination drive the RX and TX display and the individual LEDs, except from D06 and D07 (indication of Dummy Load and Tune)

The 34 bit data for each display driver is read-in serially by means of the internal SPI-Bus. The power in the individual segments is determined by the power in Brightness input, pin 19. The Brightness control circuit consists of Q03, Q04, Q05, and U07. The adjustment takes place in 4 steps:

- 1) OFF. All segments are off. U06, pin 15, 1 and 2 are high,
- 2) Min. The power in the segments is approx. 0.5 mA. U06, pin 15 goes low.
- 3) Normal. The power in the segments is approx. 1.0 mA. U06, pin 2 goes low.
- 4) Max. The power in the segments is approx. 3.5 mA. U06, pin 15 goes low.

### DUMMY LOAD AND TUNE LED

For read-out of the dummy load and tune functions, 2 separate LED's are used. These LEDs cannot be reduced or switched off after the functions have been selected. The two LEDs are controlled by U06 (74HC595) an 8 bit serial register, which is also supplied by the internal serial SPI-Bus.

### KEYBOARD LIGHT DRIVER

When the light in the keyboard is turned on, U06, pin 3 goes low, after which Q02 is turned on and supplies the 13 pcs. LEDs on the keyboard with 8V. The zener diode D15 (5V1) prevents Q02 from turning on when U06, pin 3 is high.

### LED-BAR AND LED-BAR DRIVER

For visual read-out of aerial power and RF-gain, a 10 segment LED bar with driver, i.e. U01 and U02, is used. The two signals are added in D01 and D02, and through the filter R01, R02 and C02 passed on to U02, pin 5. +5V on U02, pin 6 is reference for the signal. The individual segments in the LED bar are turned on by a rise in the signal of 500 mV.

The brightness of the LED bar is controlled by bits 4 and 5 in the 8 bit serial register U06. The adjustment follows the 4 steps, which also apply to brightness in the display. In order to be able to switch off the LED bar completely, Q01 is set off when U06, bits 4 and 5 are high.

# 5.7. COMPONENT LOCATION DISPLAY (MODULE 7)

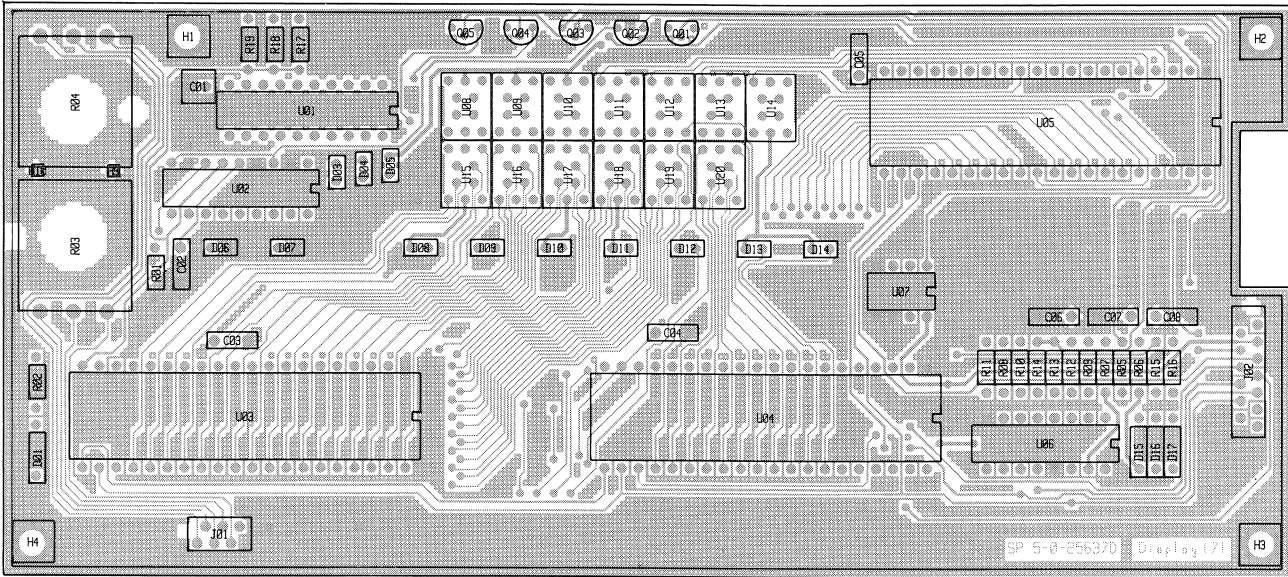

Seen from component side with upper side tracks.

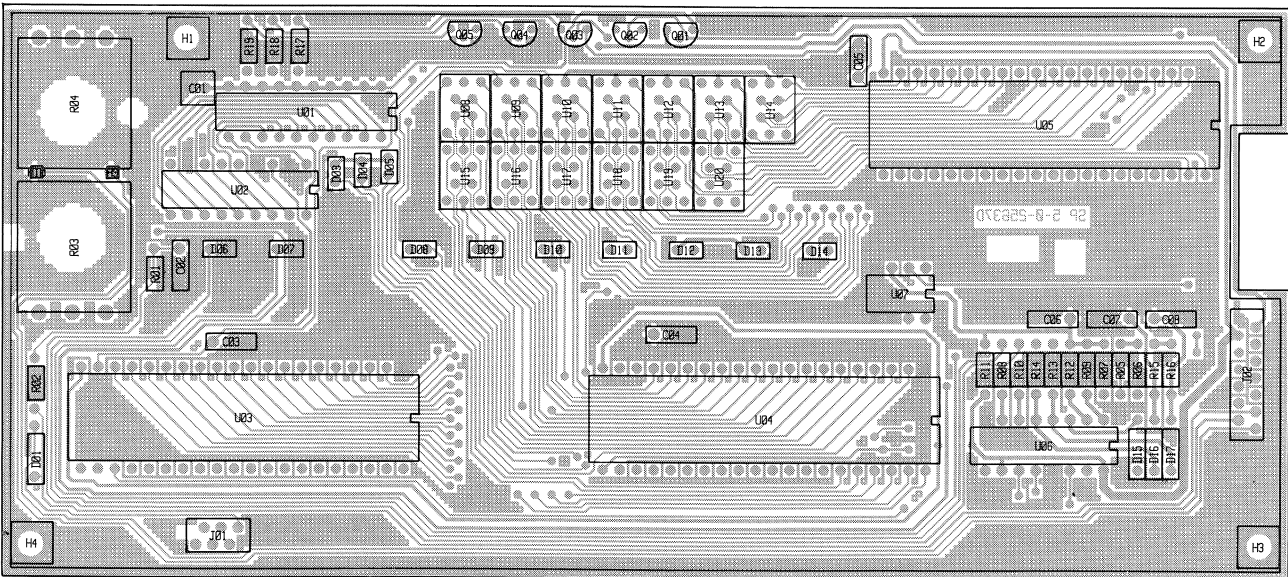

Seen from component side with lower side tracks.



RE2100 / R2122  
4-0-25637D

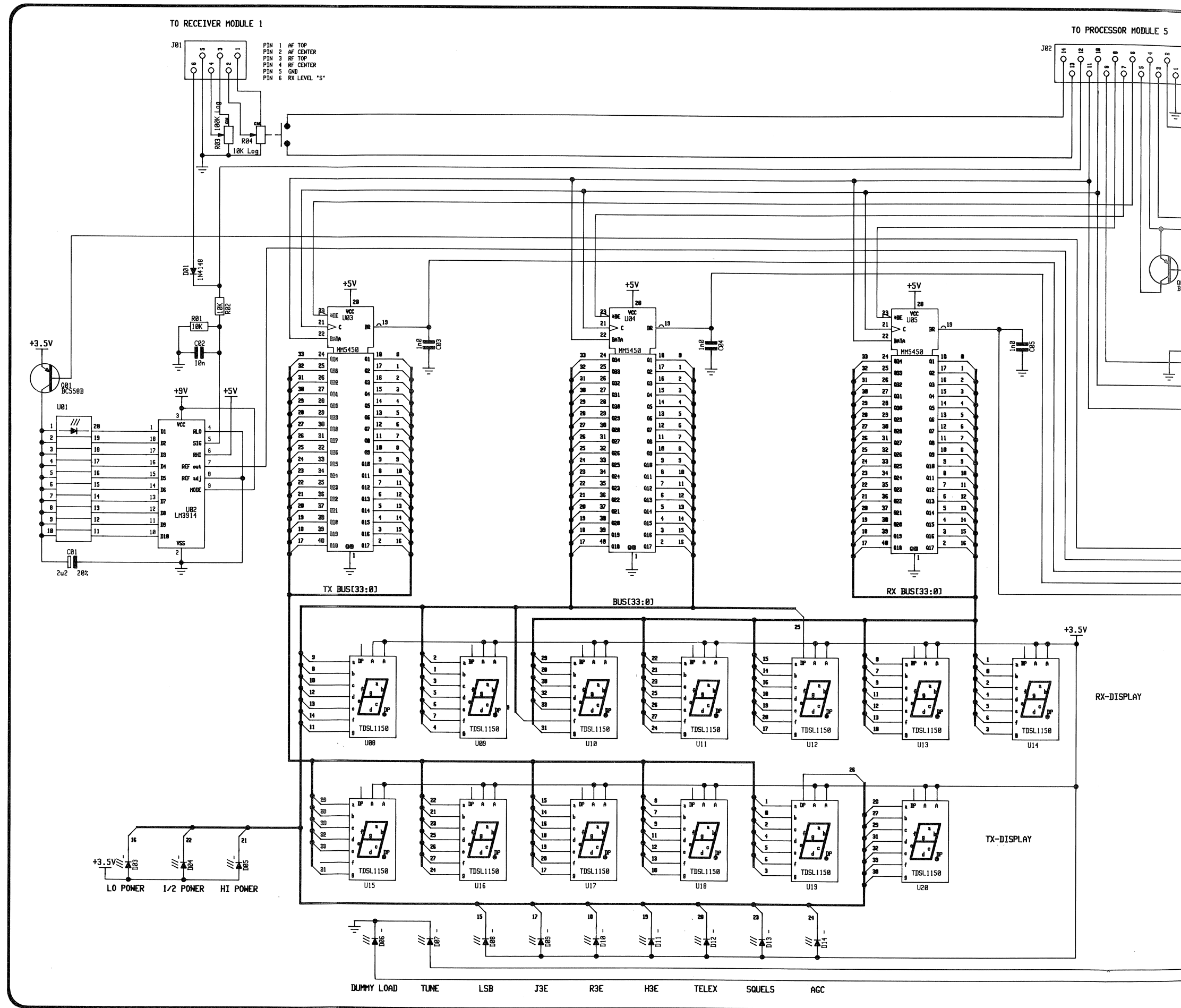



CEIVER MODULE 1

TO PROCESSOR MODULE 5

# Display Unit (7)

- PIN 1 AF TOP
- PIN 2 AF CENTER
- PIN 3 RF TOP
- PIN 4 RF CENTER
- PIN 5 GND
- PIN 6 RX LEVEL '5'

- PIN 1 GND
- PIN 2 +3.5V
- PIN 3 +5V
- PIN 4 +5V
- PIN 5 KEYBOARD LIGHT
- PIN 6 DIS 1
- PIN 7 DIS 2
- PIN 8 DIS 3
- PIN 9 DIS 4
- PIN 10 CLOCK
- PIN 11 DATA
- PIN 12 SERIAL CURRENT
- PIN 13 ON/OFF
- PIN 14 ON/OFF

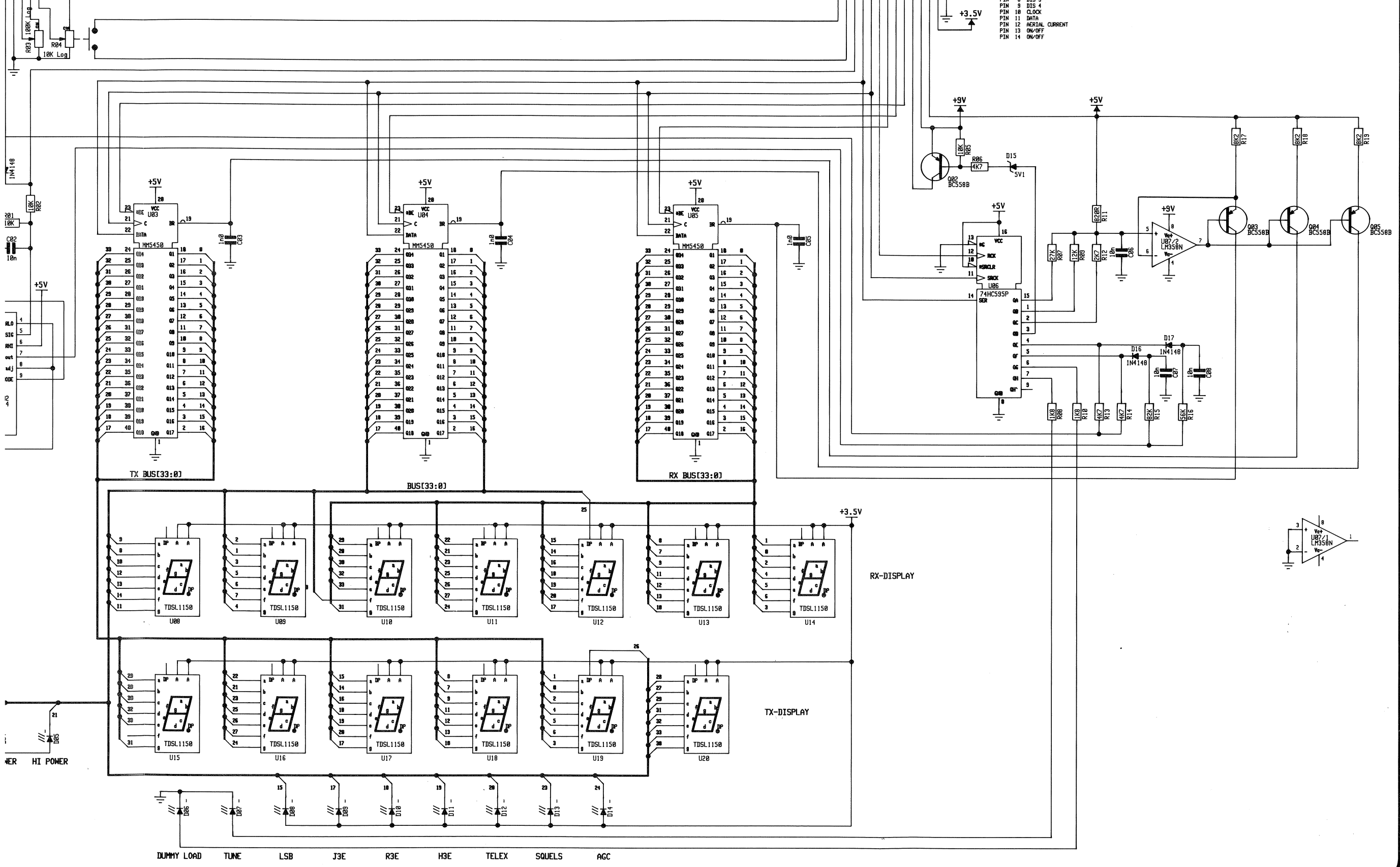

4-8-25637D



## 5.8. POWER UNIT (MODULE 8)

### REGULATORS

The power module receives three voltages +9V, +18V, and -18V from the power supply placed in the transmitter T2130. Seven regulators are converting these voltages to the different working voltages used in the RE2100.

U01 and U02 deliver +15V and -15V only to the exciter module. If the transmitter has not been used for two minutes the microprocessor shuts down the regulators U01 and U02. This takes place via the shift register U07-4 in the exciter module and the transistors Q01 and Q02. This is done to save power consumption in the stand-by position. Regulator U06 is factory adjusted to deliver 5.25V output voltage.

### RF AMPLIFIER AND FILTER

The transistors Q03, Q04, and Q05 form an RF amplifier to boost the exciter output to a level required by the transmitter. The output level can be adjusted by means of R30. To reduce harmonics produced in the exciter module a low pass filter is placed between Q03 and Q04. The RF output is a ready to send signal.

# 5.8. COMPONENT LOCATION POWER UNIT (MODULE 8)

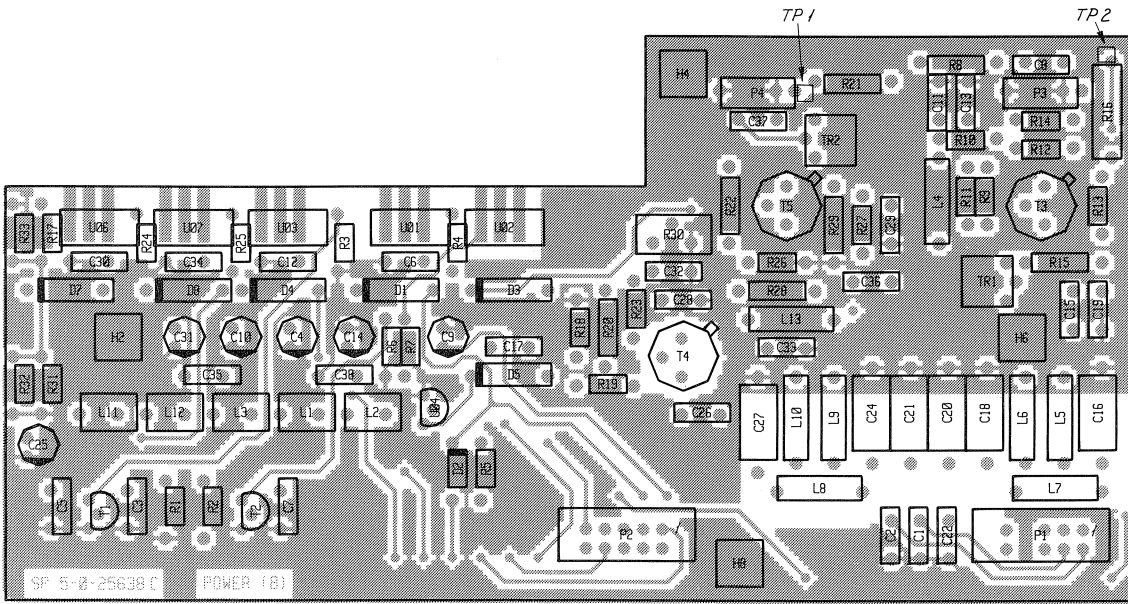

Seen from component side with upper side tracks.

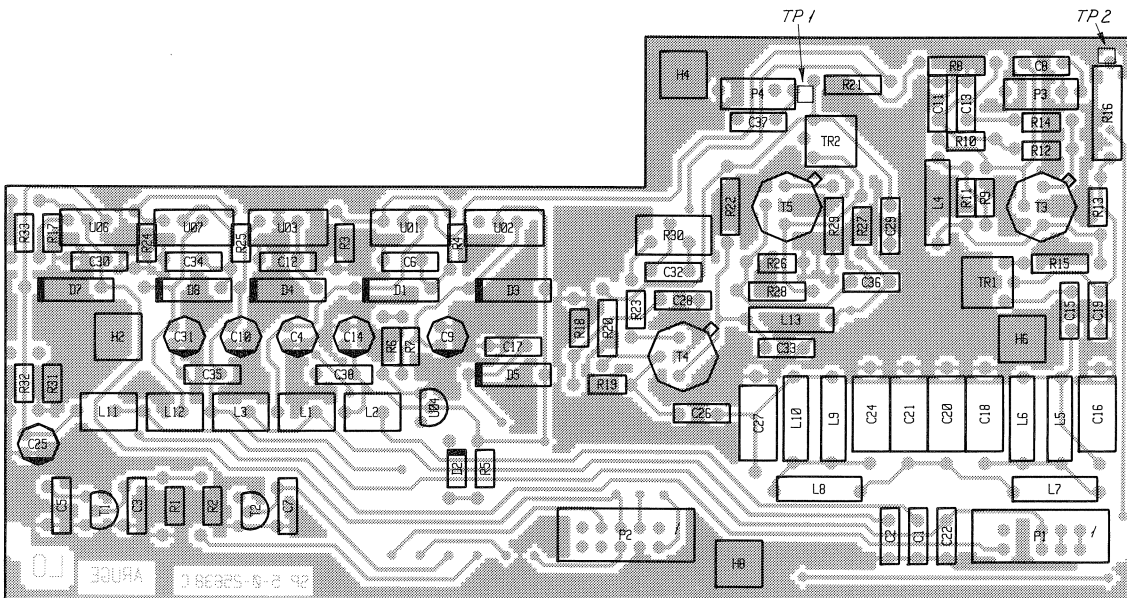

Seen from component side with lower side tracks.

# Power Module (8)

RF output into 50 ohm load.  
Service programme: SP-05-0

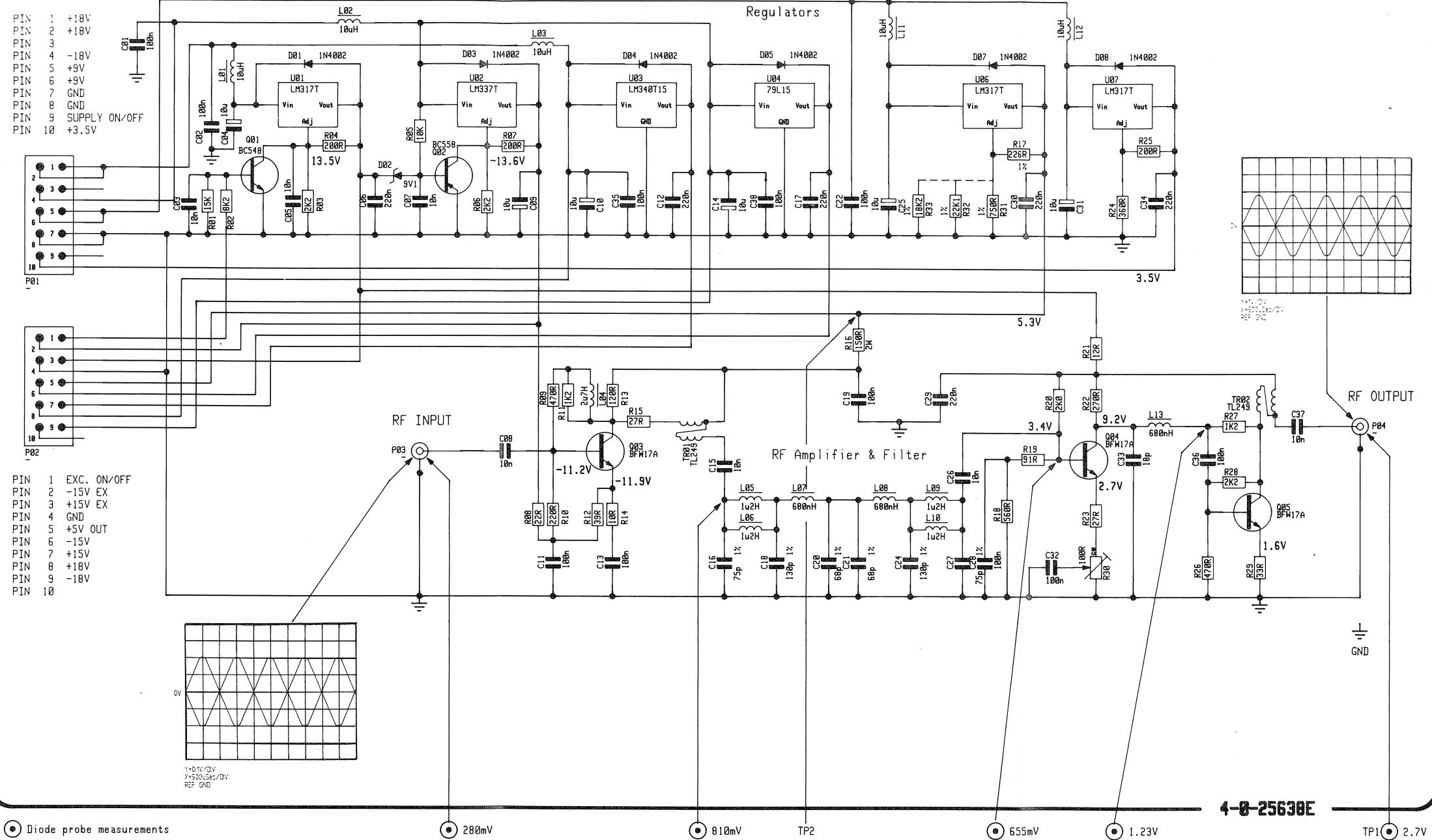

4-0-25638E





INTERCONNECTION CABLE PLAN

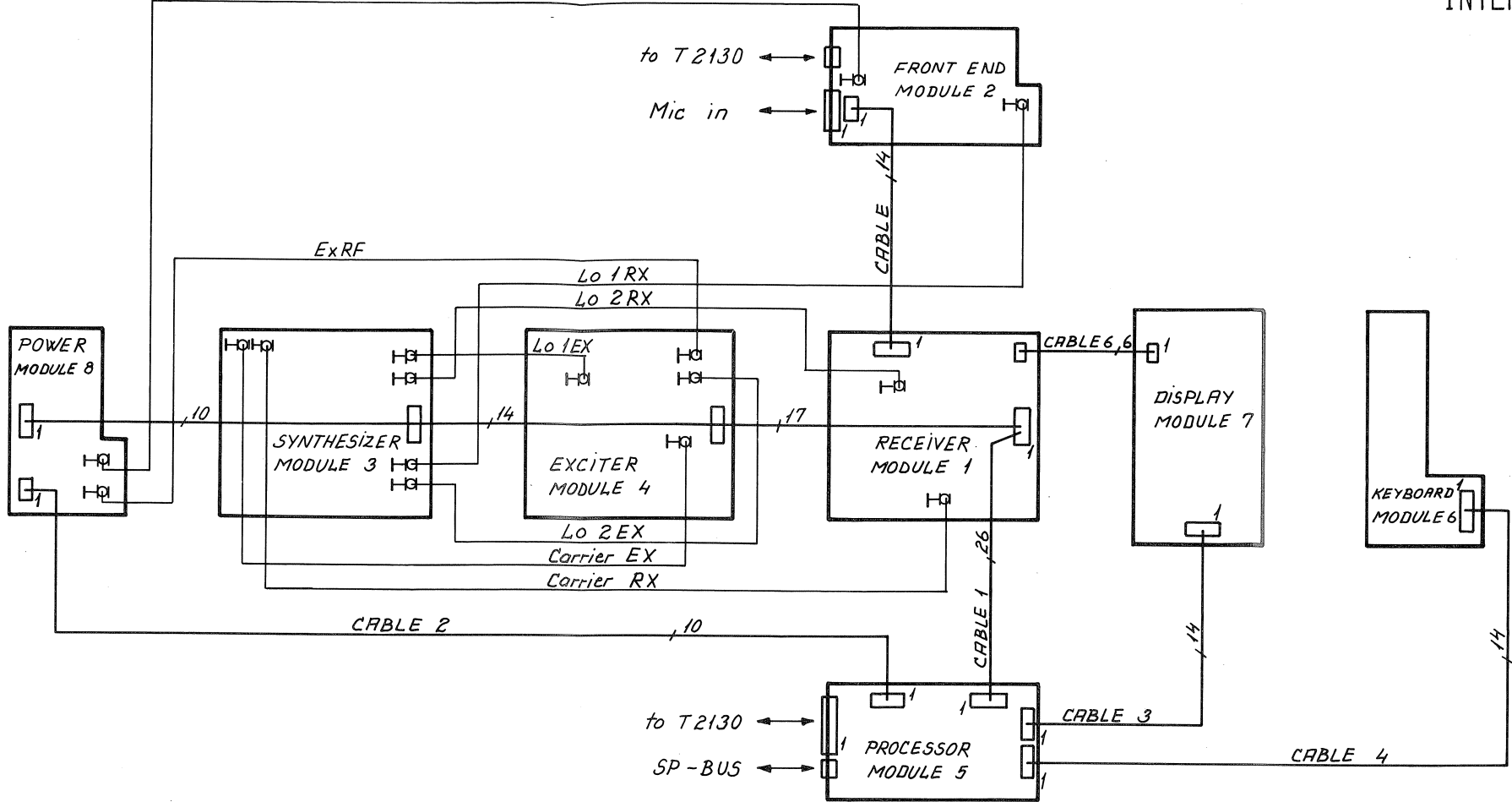

CABLE 1: MAIN CABLE - RE 2100

PROCESSOR UNIT (5)	RECEIVER UNIT (1)	EXCITER UNIT (4)	SYNTHESIZER UNIT (3)	POWER UNIT 8
1 HOOK SWITCH	1	1 EX. ON/OFF	1	1
2 +5V	2	2 -15V EX	2	2
3 -15V	3	3 +15V EX	3	3
4 +15V	4	4	4	4
5 +18V	5	5	5	5
6 -18V	6	6	6	6
7 SYNTHESIZER 1 PIN	7	7	7	7
8 SYNTHESIZER REG	8	8	8	8
9 SYNTHESIZER 2 PIN	9	9	9	9
10 CLOCK	10	10	10	10
11 DATA	11	11	11	11
12 MIC	12	12	12	12
13 TUNE/ALARM TONES	13	13	13	13
14 MODE EX	14	14	14	14
15 ATT EX	15	15	15	15
16 RF ON/OFF	16	16	16	16
17 AUX AF IN TX	17	17	17	17
18 EXT RF-CONTROL	18	18	18	18
19 0 dBm OUT	19	19	19	19
20 GND	20	20	20	20
21 RF TO AMP	21	21	21	21
22 MIC KEY	22	22	22	22
23 DISTRESS	23	23	23	23
24 SQUEALS SENSE	24	24	24	24
25 FRONT END	25	25	25	25
26 MODE RX	26	26	26	26

CABLE 2: PROCESSOR TO POWER MODULE

PROCESSOR UNIT (5)	POWER UNIT 8
1 +18V	1
2 +18V	2
3 -18V	3
4 -18V	4
5 +9V	5
6 +9V	6
7 GND	7
8 GND	8
9 -5V	9
10 +3.5V	10

CABLE 4: PROCESSOR TO KEYBOARD

PROCESSOR UNIT (5)	KEYBOARD MODULE 6
1 GND	1
2 KEYBOARD LIGHT	2
3 X5	3
4 X6	4
5 X4	5
6 X7	6
7 X8	7
8 X2	8
9 X3	9
10 Y8	10
11 Y4	11
12 Y2	12
13 Y1	13
14 X1	14

CABLE 5: RECEIVER TO FRONT END

RECEIVER UNIT (1)	FRONT END (2)
1 +5V	1
2 +15V	2
3 +15V	3
4 +18V	4
5 FRONT END	5
6 HOOK SWITCH	6
7 CLOCK	7
8 DATA	8
9 MIC	9
10 MIC KEY	10
11 SIGNAL GND	11
12 DISTRESS	12
13 EXT TELEPHONE	13
14 HOOK SWITCH	14

CABLE 3: PROCESSOR TO DISPLAY

PROCESSOR UNIT (5)	DISPLAY MODULE (7)
1 GND	1
2 +3.5V	2
3 +5V	3
4 +9V	4
5 KEYBOARD LIGHT	5
6 DIS 1	6
7 DIS 2	7
8 DIS 3	8
9 DIS 4	9
10 CLOCK	10
11 DATA	11
12 SERIAL CURRENT	12
13 ON/OFF	13
14 ON/OFF	14

CABLE 6: RECEIVER TO DISPLAY

RECEIVER UNIT (1)	DISPLAY UNIT (7)
1 RF TOP	1
2 RF CENTER	2
3 RF TOP	3
4 RF CENTER	4
5 GND	5
6 RX LEVEL "S"	6

RE2100 4-0-25918B  
RE2100 4-0-25917B

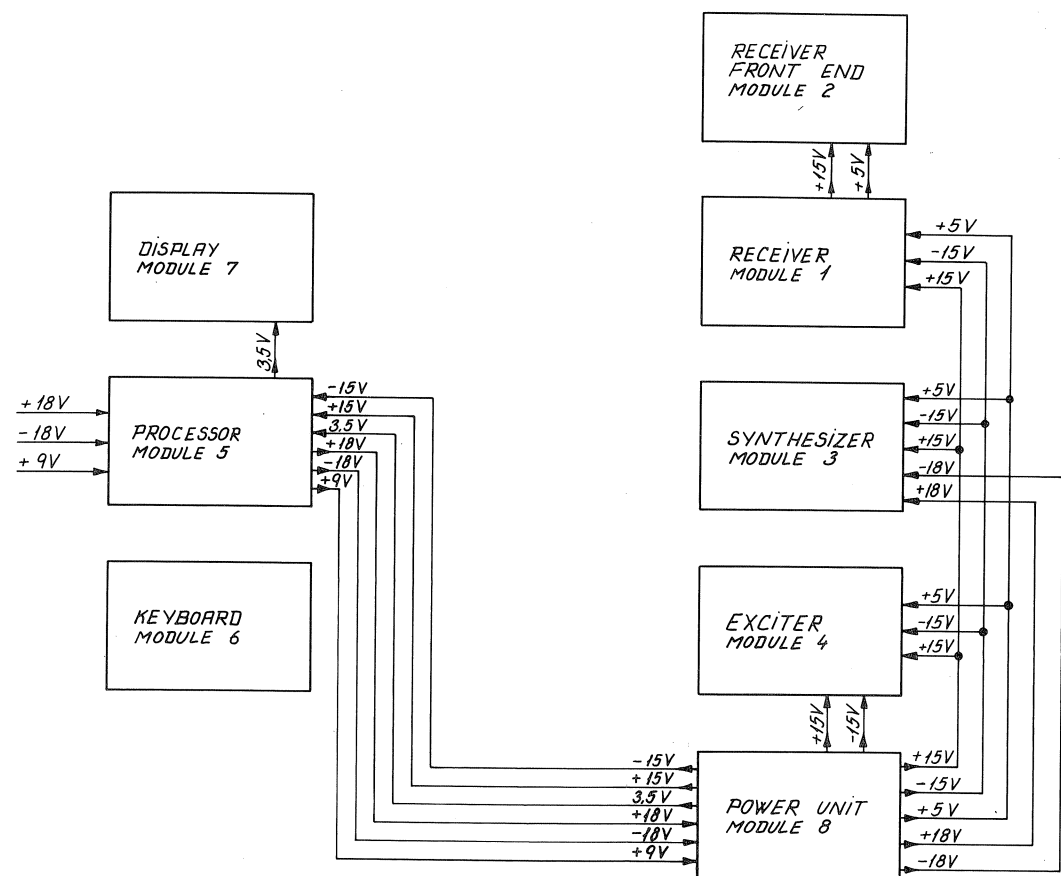

BLOCK DIAGRAM SUPPLY CABLING

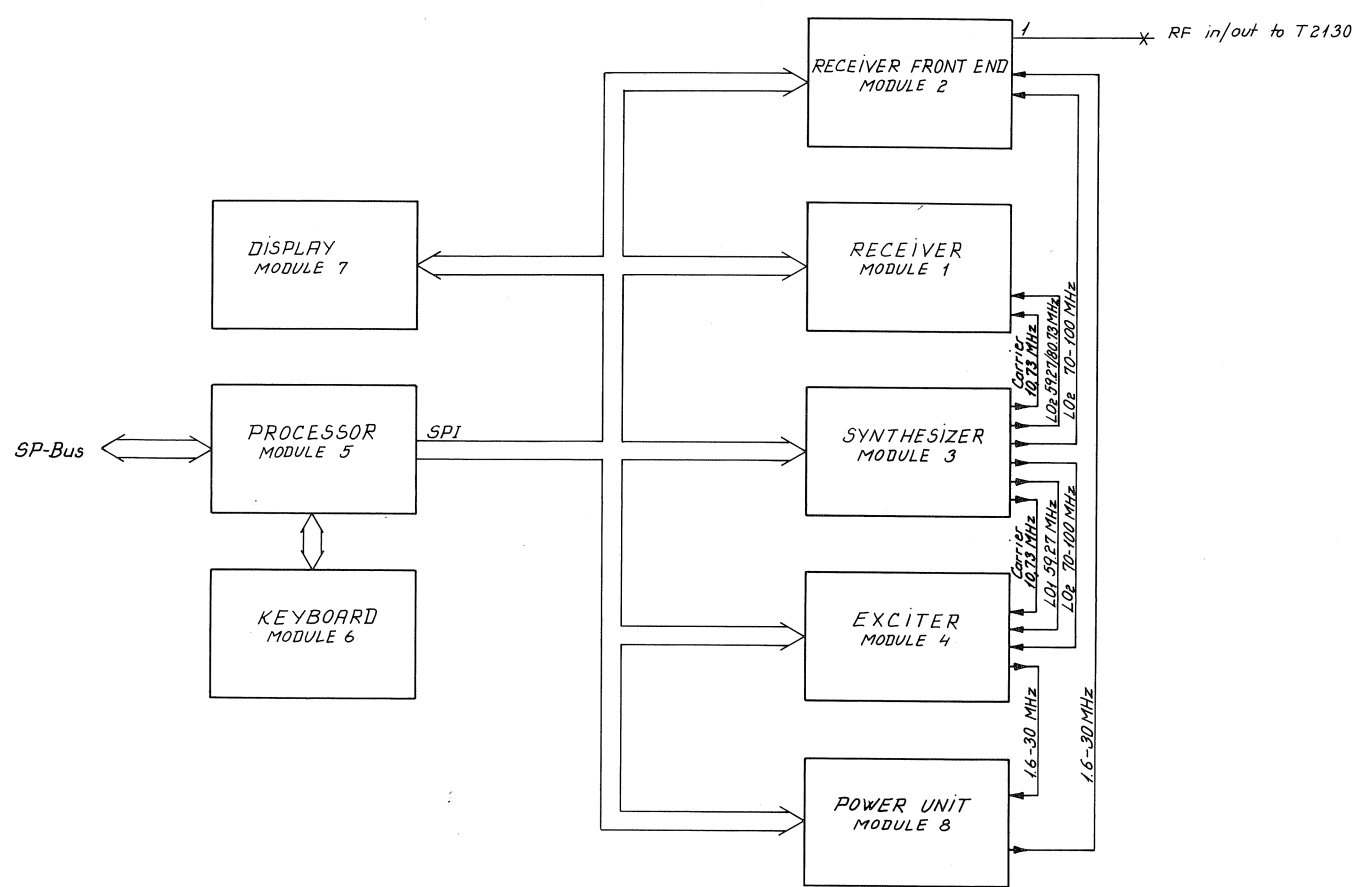

MAIN BLOCK DIAGRAM

## CONTENTS

- 6. MICROTELEPHONE INSTALLATION
- 6.1. SPECIAL INSTALLATION WITH 2 MICROTELEPHONES
- 6.2. SPECIAL INSTALLATION WITH 3 MICROTELEPHONES



# 6. MICROTELEPHONE INSTALLATION

VHF RT2047 and T2031

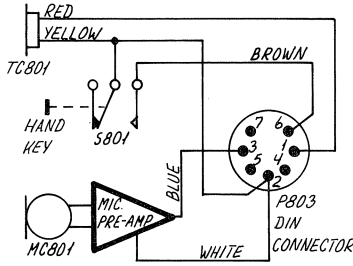

SCRAMBLER CRY2001, RT2048 and RE2100

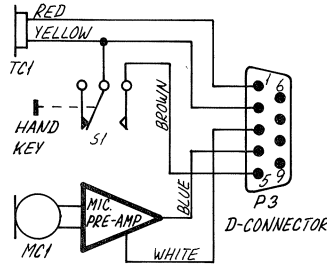

SHORTWAVE S130X

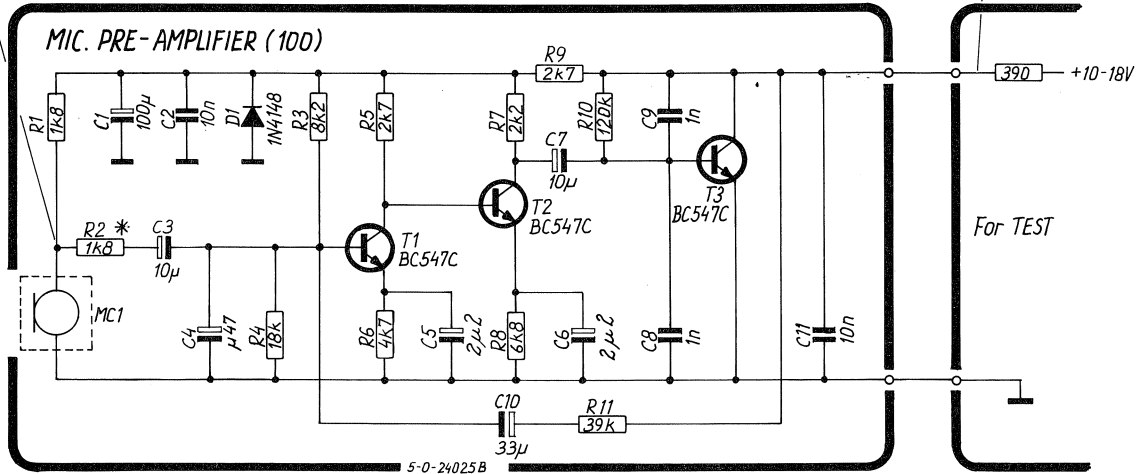
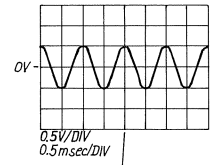
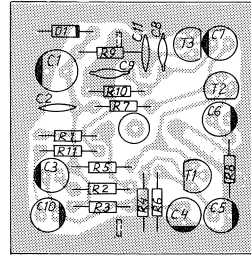
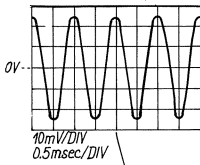
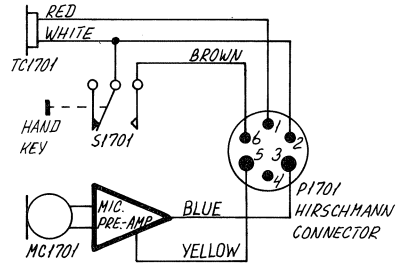

\* In orange marked microtelephone cartridge R2 is changed from 1k8 to 5k6 ohm.

(D)

RT2047, RT2048, RE2100,  
T2031, CRY2001 4-6-24025B  
4-0-24293D 4-0-24025D

POSITION	DESCRIPTION	MANUFACTURER	TYPE	S.P. NUMB	
	MICROTELEPHONE	WITH ELECTRET MIC. AMP.	ESPERA	PRINT NR.5-0-24025B	600875
C1	CAPACITOR ELECTROLYTIC	100uF 20% 10V	*ERO	EKI 00 BB 310 C	14.607
C2	CAPACITOR CERAMIC	10nF -20/+80% 50V	*KCK	HE70SJVYF103Z	15.170
C3	CAPACITOR ELECTROLYTIC	10uF 20% 35V	*ERO	EKI 00 AA 210 F	14.512
C4	CAPACITOR ELECTROLYTIC	0.47uF 20% 50V	ERO	EKI 00 AA 047 H	14.504
C5	CAPACITOR ELECTROLYTIC	10uF 20% 35V	*ERO	EKI 00 AA 210 F	14.512
C6	CAPACITOR ELECTROLYTIC	10uF 20% 35V	*ERO	EKI 00 AA 210 F	14.512
C7	CAPACITOR ELECTROLYTIC	10uF 20% 35V	*ERO	EKI 00 AA 210 F	14.512
C8	CAPACITOR CERAMIC	1nF 10% 100V	*PHILIPS	2222 630 03102	16.149
C9	CAPACITOR CERAMIC	1nF 10% 100V	*PHILIPS	2222 630 03102	16.149
C10	CAPACITOR ELECTROLYTIC	33uF 20% 16V	*ERO	EKI 00 AA 233 D	14.518
C11	CAPACITOR CERAMIC	10nF -20/+80% 50V	*KCK	HE70SJVYF103Z	15.170
D1	DIODE	1N4148	*ITT	1N4148	25.131
MC1	MICROPHONE ELECTRET	WM-034BY	MATSUSHITA	WM-034BY	46.012
R1	RESISTOR	1.8 KOHM 5% 0.33W	BEYSCHLAG	MBA 0204-00-BX-5%	01.707
R2	RESISTOR	1.8 KOHM 5% 0.33W	BEYSCHLAG	MBA 0204-00-BX-5%	01.707
R3	RESISTOR	8.2 KOHM 5% 0.33W	BEYSCHLAG	MBA 0204-00-BX-5%	01.723
R4	RESISTOR	18 KOHM 5% 0.33W	BEYSCHLAG	MBA 0204-00-BX-5%	01.732
R5	RESISTOR	2.7 KOHM 5% 0.33W	BEYSCHLAG	MBA 0204-00-BX-5%	01.711
R6	RESISTOR	4.7 KOHM 5% 0.33W	BEYSCHLAG	MBA 0204-00-BX-5%	01.717
R7	RESISTOR	2.2 KOHM 5% 0.33W	BEYSCHLAG	MBA 0204-00-BX-5%	01.709
R8	RESISTOR	6.8 KOHM 5% 0.33W	BEYSCHLAG	MBA 0204-00-BX-5%	01.721
R9	RESISTOR	2.7 KOHM 5% 0.33W	BEYSCHLAG	MBA 0204-00-BX-5%	01.711
R10	RESISTOR	120 KOHM 5% 0.33W	BEYSCHLAG	MBA 0204-00-BX-5%	01.753
R11	RESISTOR	39 KOHM 5% 0.33W	BEYSCHLAG	MBA 0204-00-BX-5%	01.740
S1	MICROSWITCH	E62-10H PDT	CHERRY	E62-10H PDT	44.025
T1	TRANSISTOR	BC547C	SGS	BC547C	28.068
T2	TRANSISTOR	BC547C	SGS	BC547C	28.068
T3	TRANSISTOR	BC547C	SGS	BC547C	28.068
TC1	TELEPHONE CARTRIDGE	200 OHM	S.E.K. (KIRK)	0113.2518 (0113.2510)	46.010



# 6.1. SPECIAL INSTALLATION WITH 2 MICROTELEPHONES: H2086 FOR SCRAMBLER CRY2001, RT2048 AND RE2100 H2087 FOR VHF RT2047 AND SSB T2031

## MICROTELEPHONE ONE WITH PREFERENCE

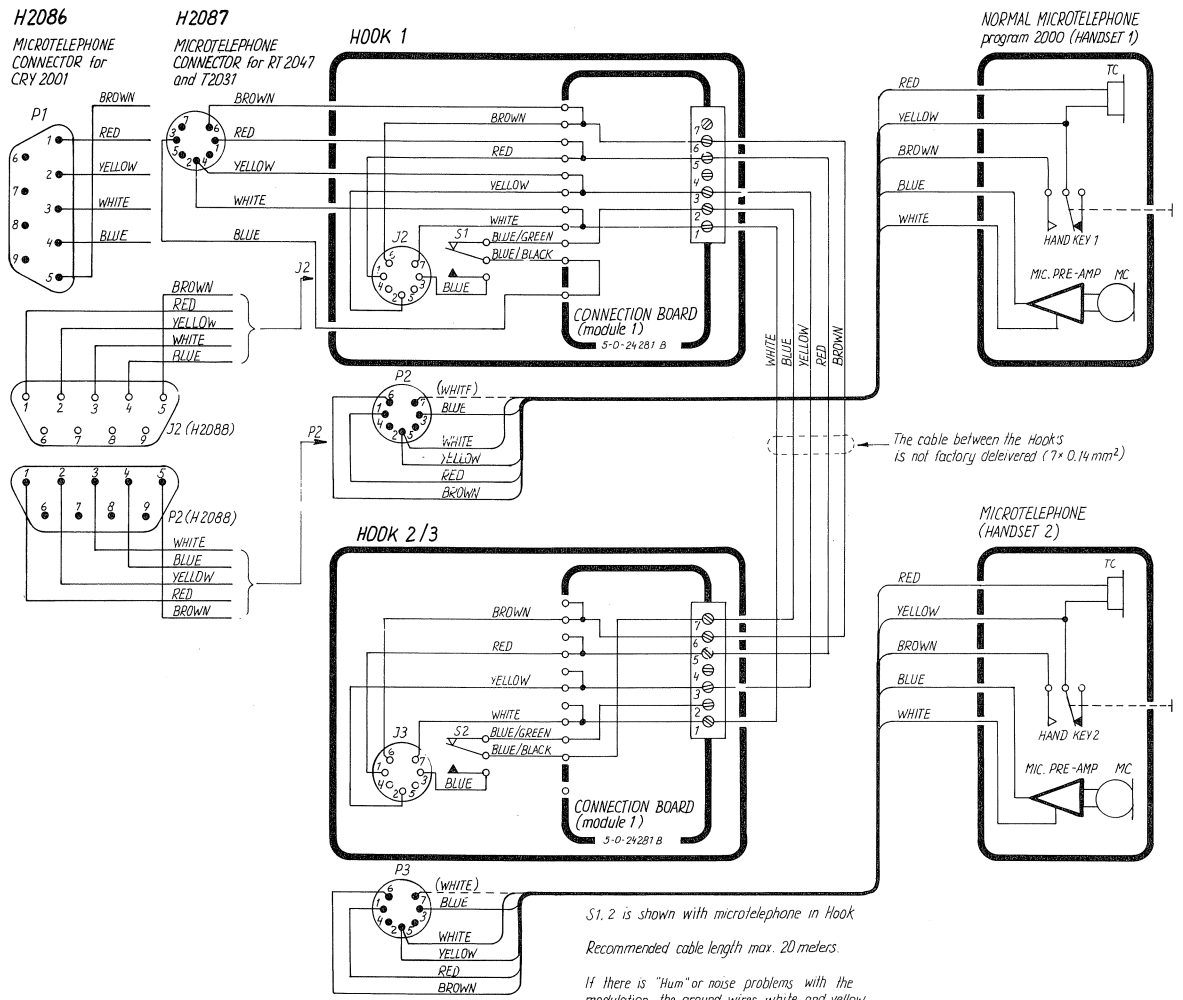

CRY2001, RT2047, T2031, RT2048, RE2100

0-24803B

## 6.2. SPECIAL INSTALLATION WITH 3 MICROTELEPHONES: H2088 FOR SCRAMBLER CRY2001, RT2048 AND RE2100 H2089 FOR VHF RT2047 AND SSB T2031

### MICROTELEPHONE ONE WITH PREFERENCE

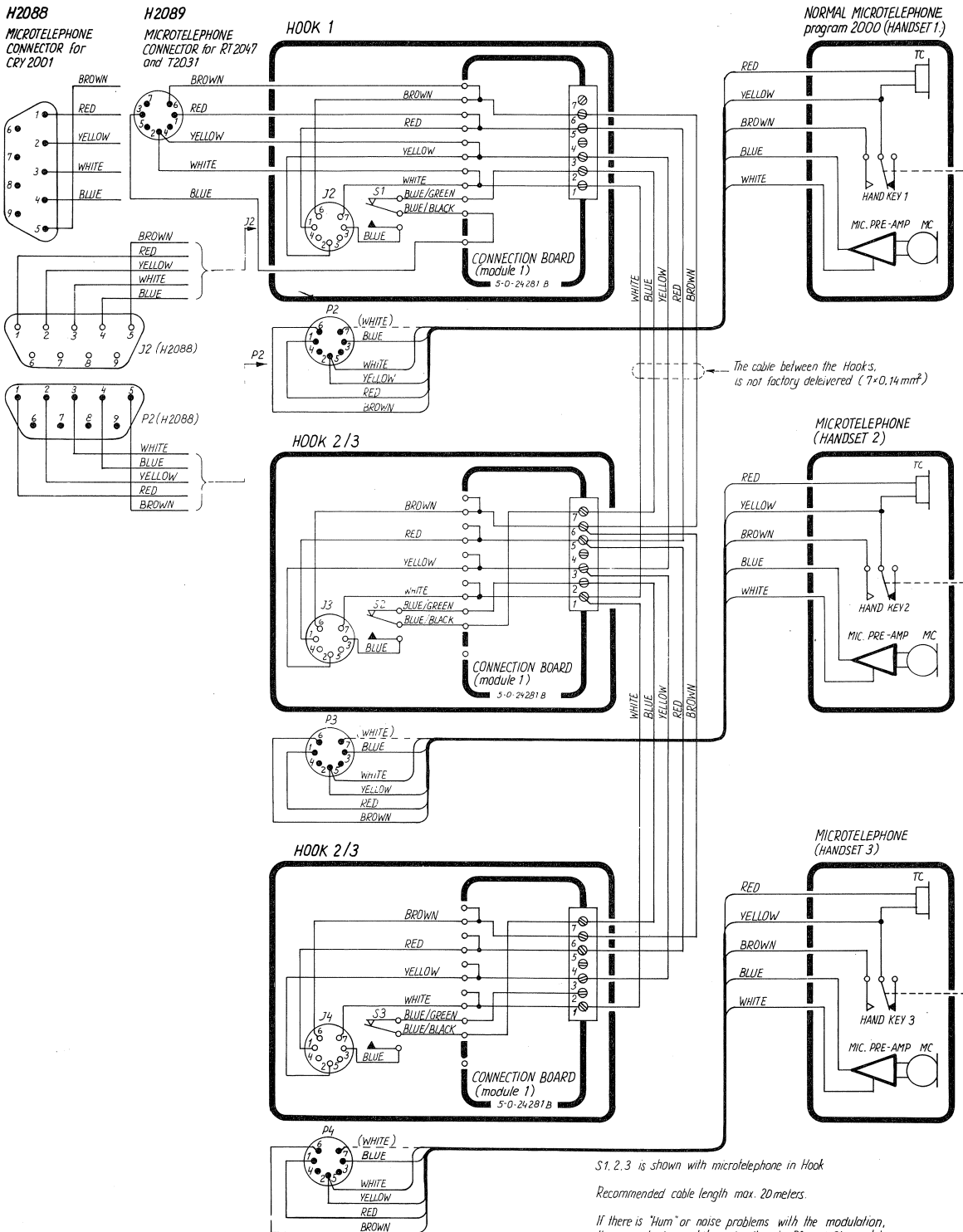

CRY2001, RT2047, T2031, RT2048, RE2100  
-0-24804A



CONTENTS

7. PARTS LIST



POSITION	DESCRIPTION	MANUFACTURER	TYPE	S.P. NUMBER	
	HF 55B RE2100	SAILOR GREEN	ESPERA	HF 55B RE2100 SAILOR GREEN	8U2100
VARIOUS	1/4 BOX CABINET	SAILOR GREEN		200101 GRØN RILSAN	141.750
VARIOUS	FRONTPLATE RE2100	SAILOR GREEN		225711 LAK	143.558
VARIOUS	HOUSING FOR REAR PLATE	BLACK PLASTIC		48.611 MALES SORT	162.080
VARIOUS	HOUSING FOR FRONT CHASSIS	BLACK PLASTIC	SANDER PLAST	0-3-25719B & 225710 x 2	164.070
VARIOUS	KEYBOARD FOIL RE2100/C2140		ESPERA	1-0-25709B	225709
VARIOUS	KNOB BLACK	Ø9.5xØ6x27mm	SANDER PLAST	TG.0-3-25750A	48.689
VARIOUS	COVER FOR ALLEN SCREW		SANDER PLAST	0-3-25350A	48.699
VARIOUS	COAX CABLE Ø3x23cm/BLUE		ESPERA	3-0-26077	526077
VARIOUS	COAX CABLE Ø3x13cm/BLACK		ESPERA	3-0-26084	526084
VARIOUS	COAX CABLE Ø3x33.5cm/YELL		ESPERA	3-0-26085	526085
VARIOUS	COAX CABLE Ø3x5.8cm		ESPERA	3-0-26086	526086
VARIOUS	COAX CABLE Ø3x28.5cm/RED		ESPERA	3-0-26087	526087
VARIOUS	COAX CABLE Ø3x18cm		ESPERA	3-0-26088	526088
VARIOUS	COAX CABLE Ø3x28.5cm		ESPERA	3-0-26095	526095
VARIOUS	COAX CABLE Ø3x51.5cm		ESPERA	3-0-26096	526096
VARIOUS	COAX CABLE Ø3x35.5cm/RED		ESPERA	3-0-26097	526097
VARIOUS	INTERCONNECTION CABLE	6 POLES L=60mm	AMP	3-0-26009 & 954294-1	56.008
VARIOUS	INTERCONNECTION CABLE	14 POLES L=50mm	AMP	3-0-26010 & 954298-0	56.009
VARIOUS	INTERCONNECTION CABLE	14 POLES L=105mm	AMP	3-0-26011 & 954298-1	56.010
VARIOUS	INTERCONNECTION CABLE	10 POLES L=125mm	3M	3-0-26089	56.031
VARIOUS	INTERCONNECTION CABLE	14 POLES L=75mm	3M	3-0-26091	56.032
VARIOUS	INTERCONNECTION CABLE	26:26:20:14:10 POLES	3M	3-0-26090A	56.033
VARIOUS	OPERATION MANUAL	RE2100	S.P.RADIO A/S		B2100
VARIOUS	SERVICE AND SALES AGENTS	ADDRESSES WORLD WIDE	S.P.RADIO A/S		F10006B
VARIOUS	MANUAL RE2100 ENGLISH		S.P.RADIO A/S		M21006B
-1	RECEIVER MODULE 1	RE2100	ESPERA	5-0-25631H	625631
-2	Rx FRONT END MODULE 2	RE2100	ESPERA	5-0-25632G	625632
-3	SYNTHESIZER MODULE 3	RE2100, TCX0: 0.34ppm	ESPERA	625633 w. 0.34ppm TCX0	727070
-4	EXCITER MODULE 4	RE2100	ESPERA	5-0-25634C	625634
-5	PROCESSOR MODULE 5	RE2100	ESPERA	5-0-25635K	625635
-6	KEYBOARD MODULE 6	RE2100/C2140	ESPERA	5-0-25636E	625636
-7	DISPLAY MODULE 7	RE2100/C2140	ESPERA	5-0-25637D	625637
-8	POWER MODULE 8	RE2100	ESPERA	5-0-25638C	625638
VARIOUS	MICROTELEPHONE WITH	CRADLE CRY2001/RE2100	ESPERA	3-0-25772	725772
U6-5	PROGRAMMED PROM U6-5	RF2100	ESPERA	0-0-26166 / C1086H - E8B5	726166



POSITION	DESCRIPTION		MANUFACTOR	TYPE	S.P. NUMBER
	RECEIVER MODULE 1	RE2100	ESPERA	5-0-25631H	625631
C1-1	CAPACITOR CERAMIC	470pF 10% 500VDC	KCK	RT-HM60 SK YB 471 K AMMO PACK	16.095
C2-1	CAPACITOR CERAMIC	10pF 5% N470 50VDC	NKE	DT 330 758S TH 100 D 50V FLAT PACK	15.848
C3-1	CAPACITOR CERAMIC	10nF -20/+80% CL2 50VDC	KCK	RT-HE70 SK YF 103 Z AMMO PACK	15.170
C4-1	CAPACITOR CERAMIC	68pF 5% N150 50VDC	NKE	DT 380 758S PH 680 J 50V FLAT PACK	15.115
C5-1	CERAMIC CAPACITOR	22pF 5% N150 50VDC	NKE	DT 340 758S PH 220 J 50V FLAT PACK	15.075
C6-1	CAPACITOR CERAMIC	470pF 10% 500VDC	KCK	RT-HM60 SK YB 471 K AMMO PACK	16.095
C7-1	CAPACITOR CERAMIC	10nF -20/+80% CL2 50VDC	KCK	RT-HE70 SK YF 103 Z AMMO PACK	15.170
C8-1	CAPACITOR CERAMIC	10nF -20/+80% CL2 50VDC	KCK	RT-HE70 SK YF 103 Z AMMO PACK	15.170
C9-1	CAPACITOR CERAMIC	470pF 10% 500VDC	KCK	RT-HM60 SK YB 471 K AMMO PACK	16.095
C10-1	CAPACITOR CERAMIC	10nF -20/+80% CL2 50VDC	KCK	RT-HE70 SK YF 103 Z AMMO PACK	15.170
C11-1	CAPACITOR CERAMIC	68pF 5% N150 50VDC	NKE	DT 380 758S PH 680 J 50V FLAT PACK	15.115
C12-1	CAPACITOR CERAMIC	470pF 10% 500VDC	KCK	RT-HM60 SK YB 471 K AMMO PACK	16.095
C13-1	CAPACITOR CERAMIC	47pF 5% N150 50VDC	KCK	RT-HE60-SK PH 470 J AMMO PACK	15.100
C14-1	CAPACITOR CERAMIC	10nF -20/+80% CL2 50VDC	KCK	RT-HE70 SK YF 103 Z AMMO PACK	15.170
C15-1	CAPACITOR CERAMIC	470pF 10% 500VDC	KCK	RT-HM60 SK YB 471 K AMMO PACK	16.095
C16-1	CAPACITOR CERAMIC	470pF 10% 500VDC	KCK	RT-HM60 SK YB 471 K AMMO PACK	16.095
C17-1	CAPACITOR CERAMIC	6pF +/-0.5pF N150 50VDC	NKE	DT 330 758S PH 6R0 D 50V FLAT PACK	15.019
C18-1	CAPACITOR TRIMMING	9-80pF PTFE	DAU	109.6901.090	17.205
C19-1	CAPACITOR CERAMIC	1nF 10% CL2 500VDC	KCK	RT-HM60 SK YB 102 K AMMO PACK	15.160
C20-1	CAPACITOR MKT	0.1uF 10% 63VDC	PHILIPS	2222 370 78104	11.136
C21-1	CAPACITOR CERAMIC	10nF -20/+80% CL2 50VDC	KCK	RT-HE70 SK YF 103 Z AMMO PACK	15.170
C22-1	CAPACITOR CERAMIC	1nF 10% CL2 500VDC	KCK	RT-HM60 SK YB 102 K	15.160

POSITION	DESCRIPTION		MANUFACTOR	TYPE	S.P. NUMBER
C23-1	CAPACITOR MKT	0.1uF 10% 63VDC	PHILIPS	AMMO PACK 2222 370 78104	11.136
C24-1	CAPACITOR MKT	0.1uF 10% 63VDC	PHILIPS	2222 370 78104	11.136
C25-1	CAPACITOR CERAMIC	1nF 10% CL2 500VDC	KCK	RT-HM60 SK YB 102 K AMMO PACK	15.160
C26-1	CAPACITOR MKT	0.1uF 10% 63VDC	PHILIPS	2222 370 78104	11.136
C27-1	CAPACITOR MKT	0.1uF 10% 63VDC	PHILIPS	2222 370 78104	11.136
C28-1	CAPACITOR CERAMIC	10nF -20/+80% CL2 50VDC	KCK	RT-HE70 SK YF 103 Z AMMO PACK	15.170
C29-1	CAPACITOR CERAMIC	10nF -20/+80% CL2 50VDC	KCK	RT-HE70 SK YF 103 Z AMMO PACK	15.170
C30-1	CAPACITOR CERAMIC	10nF -20/+80% CL2 50VDC	KCK	RT-HE70 SK YF 103 Z AMMO PACK	15.170
C31-1	CAPACITOR CERAMIC	27pF 5% N150 50VDC	NKE	DT 350 758S PH 270 J 50V FLAT PACK	15.076
C32-1	CAPACITOR CERAMIC	10nF -20/+80% CL2 50VDC	KCK	RT-HE70 SK YF 103 Z AMMO PACK	15.170
C33-1	CAPACITOR CERAMIC	10nF -20/+80% CL2 50VDC	KCK	RT-HE70 SK YF 103 Z AMMO PACK	15.170
C34-1	CAPACITOR CERAMIC	10nF -20/+80% CL2 50VDC	KCK	RT-HE70 SK YF 103 Z AMMO PACK	15.170
C35-1	CAPACITOR CERAMIC	10nF -20/+80% CL2 50VDC	KCK	RT-HE70 SK YF 103 Z AMMO PACK	15.170
C36-1	CAPACITOR CERAMIC	10nF -20/+80% CL2 50VDC	KCK	RT-HE70 SK YF 103 Z AMMO PACK	15.170
C37-1	CAPACITOR CERAMIC	27pF 5% N150 50VDC	NKE	DT 350 758S PH 270 J 50V FLAT PACK	15.076
C38-1	CAPACITOR CERAMIC	10nF -20/+80% CL2 50VDC	KCK	RT-HE70 SK YF 103 Z AMMO PACK	15.170
C39-1	CAPACITOR CERAMIC	10nF -20/+80% CL2 50VDC	KCK	RT-HE70 SK YF 103 Z AMMO PACK	15.170
C40-1	CAPACITOR CERAMIC	10nF -20/+80% CL2 50VDC	KCK	RT-HE70 SK YF 103 Z AMMO PACK	15.170
C41-1	CAPACITOR CERAMIC	10nF -20/+80% CL2 50VDC	KCK	RT-HE70 SK YF 103 Z AMMO PACK	15.170
C42-1	CAPACITOR CERAMIC	10nF -20/+80% CL2 50VDC	KCK	RT-HE70 SK YF 103 Z AMMO PACK	15.170
C43-1	CAPACITOR CERAMIC	27pF 5% N150 50VDC	NKE	DT 350 758S PH 270 J 50V FLAT PACK	15.076
C44-1	CAPACITOR CERAMIC	10nF -20/+80% CL2 50VDC	KCK	RT-HE70 SK YF 103 Z AMMO PACK	15.170
C45-1	CAPACITOR CERAMIC	10nF -20/+80% CL2 50VDC	KCK	RT-HE70 SK YF 103 Z AMMO PACK	15.170
C46-1	CAPACITOR CERAMIC	10nF -20/+80% CL2 50VDC	KCK	RT-HE70 SK YF 103 Z	15.170

RE2100 35/91

POSITION	DESCRIPTION		MANUFACTOR	TYPE	S.P.NUMBER
C47-1	CAPACITOR CERAMIC	10nF -20/+80% CL2 50VDC	KCK	AMMO PACK RT-HE70 SK YF 103 Z	15.170
C48-1	CAPACITOR CERAMIC	10nF -20/+80% CL2 50VDC	KCK	AMMO PACK RT-HE70 SK YF 103 Z	15.170
C49-1	CAPACITOR CERAMIC	10nF -20/+80% CL2 50VDC	KCK	AMMO PACK RT-HE70 SK YF 103 Z	15.170
C50-1	CAPACITOR CERAMIC	10nF -20/+80% CL2 50VDC	KCK	AMMO PACK RT-HE70 SK YF 103 Z	15.170
C51-1	CAPACITOR CERAMIC	10nF -20/+80% CL2 50VDC	KCK	AMMO PACK RT-HE70 SK YF 103 Z	15.170
C52-1	CAPACITOR CERAMIC	10nF -20/+80% CL2 50VDC	KCK	AMMO PACK RT-HE70 SK YF 103 Z	15.170
C53-1	CAPACITOR CERAMIC	10nF -20/+80% CL2 50VDC	KCK	AMMO PACK RT-HE70 SK YF 103 Z	15.170
C54-1	CAPACITOR CERAMIC	10nF -20/+80% CL2 50VDC	KCK	AMMO PACK RT-HE70 SK YF 103 Z	15.170
C55-1	CAPACITOR ELECTROLYTIC	100uF -10/+50% 25VDC	ERO	EKM 00 CC 310 E G5	14.610
C57-1	CAPACITOR ELECTROLYTIC	10uF 20% 35VDC	ERO	EKI 00 AA 210 F M9	14.512
C58-1	CAPACITOR ELECTROLYTIC	10uF 20% 35VDC	ERO	EKI 00 AA 210 F M9	14.512
C59-1	CAPACITOR ELECTROLYTIC	47uF 20% 25VDC	ERO	EKI 00 BB 247 E M9	14.524
C60-1	CAPACITOR ELECTROLYTIC	10uF 20% 35VDC	ERO	EKI 00 AA 210 F M9	14.512
C61-1	CAPACITOR MKT	330nF 10% 63VDC	PHILIPS	2222 370 78334	11.189
C62-1	CAPACITOR ELECTROLYTIC	47uF 20% 25VDC	ERO	EKI 00 BB 247 E M9	14.524
C63-1	CAPACITOR ELECTROLYTIC	33uF 20% 16VDC	ERO	EKI 00 AA 233 D M9	14.518
C64-1	CAPACITOR MKT	1uF 5% 63VDC	PHILIPS	2222 370 79105	11.190
C65-1	CAPACITOR MKT	1uF 5% 63VDC	PHILIPS	2222 370 79105	11.190
C66-5	CAPACITOR MKT	1uF 5% 63VDC	PHILIPS	2222 370 79105	11.190
C67-1	CAPACITOR MKT	1uF 5% 63VDC	PHILIPS	2222 370 79105	11.190
C68-1	CAPACITOR ELECTROLYTIC	22uF 20% 25VDC	ELNA	RJ2-25-V-220-M-T34	14.514
C69-1	CAPACITOR ELECTROLYTIC	10uF 20% 35VDC	ERO	EKI 00 AA 210 F M9	14.512
C70-1	CAPACITOR CERAMIC	10nF -20/+80% CL2 50VDC	KCK	AMMO PACK RT-HE70 SK YF 103 Z	15.170
C71-1	CAPACITOR ELECTROLYTIC	22uF 20% 25VDC	ELNA	RJ2-25-V-220-M-T34	14.514
C72-1	CAPACITOR MKT	100nF 5% 63VDC	PHILIPS	2222 370 79104	11.135
C73-1	CAPACITOR CERAMIC	10nF -20/+80% CL2 50VDC	KCK	AMMO PACK RT-HE70 SK YF 103 Z	15.170
C74-1	CAPACITOR MKT	10nF 5% 63VDC	PHILIPS	2222 370 89103	11.134
C75-1	CAPACITOR CERAMIC	10nF -20/+80% CL2 50VDC	KCK	AMMO PACK RT-HE70 SK YF 103 Z	15.170
C76-1	CAPACITOR CERAMIC	10nF -20/+80% CL2 50VDC	KCK	AMMO PACK RT-HE70 SK YF 103 Z	15.170
C77-1	CAPACITOR CERAMIC	10nF -20/+80% CL2 50VDC	KCK	AMMO PACK RT-HE70 SK YF 103 Z	15.170

POSITION	DESCRIPTION		MANUFACTOR	TYPE	S.P.NUMBER
C78-1	CAPACITOR ELECTROLYTIC	22uF 20% 25VDC	ELNA	RJ2-25-V-220-M-T34	14.514
C79-1	CAPACITOR CERAMIC	10nF -20/+80% CL2 50VDC	KCK	AMMO PACK RT-HE70 SK YF 103 Z	15.170
C80-1	CAPACITOR CERAMIC	10nF -20/+80% CL2 50VDC	KCK	AMMO PACK RT-HE70 SK YF 103 Z	15.170
C81-1	CAPACITOR CERAMIC	10nF -20/+80% CL2 50VDC	KCK	AMMO PACK RT-HE70 SK YF 103 Z	15.170
C82-1	CAPACITOR CERAMIC	10nF -20/+80% CL2 50VDC	KCK	AMMO PACK RT-HE70 SK YF 103 Z	15.170
C83-1	CAPACITOR CERAMIC	10nF -20/+80% CL2 50VDC	KCK	AMMO PACK RT-HE70 SK YF 103 Z	15.170
C84-1	CAPACITOR ELECTROLYTIC	10uF 20% 35VDC	ERO	EKI 00 AA 210 F M9	14.512
C85-1	CAPACITOR ELECTROLYTIC	10uF 20% 35VDC	ERO	EKI 00 AA 210 F M9	14.512
C86-1	CAPACITOR CERAMIC	10nF -20/+80% CL2 50VDC	KCK	AMMO PACK RT-HE70 SK YF 103 Z	15.170
C87-1	CAPACITOR MKT	1uF 5% 63VDC	PHILIPS	2222 370 79105	11.190
C88-1	CAPACITOR CERAMIC	10nF -20/+80% CL2 50VDC	KCK	AMMO PACK RT-HE70 SK YF 103 Z	15.170
C89-1	CAPACITOR CERAMIC	10nF -20/+80% CL2 50VDC	KCK	AMMO PACK RT-HE70 SK YF 103 Z	15.170
C90-1	CAPACITOR CERAMIC	10nF -20/+80% CL2 50VDC	KCK	AMMO PACK RT-HE70 SK YF 103 Z	15.170
C91-1	CAPACITOR CERAMIC	10nF -20/+80% CL2 50VDC	KCK	AMMO PACK RT-HE70 SK YF 103 Z	15.170
C92-1	CAPACITOR CERAMIC	10nF -20/+80% CL2 50VDC	KCK	AMMO PACK RT-HE70 SK YF 103 Z	15.170
C93-1	CAPACITOR MKT	100nF 5% 63VDC	PHILIPS	2222 370 79104	11.135
C94-1	CAPACITOR ELECTROLYTIC	22uF 20% 25VDC	ELNA	RJ2-25-V-220-M-T34	14.514
C95-1	CAPACITOR ELECTROLYTIC	22uF 20% 25VDC	ELNA	RJ2-25-V-220-M-T34	14.514
C96-1	CAPACITOR MKT	100nF 5% 63VDC	PHILIPS	2222 370 79104	11.135
C97-1	CAPACITOR ELECTROLYTIC	22uF 20% 25VDC	ELNA	RJ2-25-V-220-M-T34	14.514
C98-1	CAPACITOR MKT	1uF 5% 63VDC	PHILIPS	2222 370 79105	11.190
C99-1	CAPACITOR MKT	1uF 5% 63VDC	PHILIPS	2222 370 79105	11.190
C100-1	CAPACITOR MKT	10nF 5% 63VDC	PHILIPS	2222 370 89103	11.134
C101-1	CAPACITOR CERAMIC	220nF 10% 500VDC CL2	KCK	AMMO PACK RT-HM60-SK YB 221 K	16.090
C102-1	CAPACITOR MKT	22nF 10% 100VDC	PHILIPS	2222 370 88223	11.175
C103-1	CAPACITOR CERAMIC	10nF -20/+80% CL2 50VDC	KCK	AMMO PACK RT-HE70 SK YF 103 Z	15.170
C104-1	CAPACITOR CERAMIC	220nF 10% 500VDC CL2	KCK	AMMO PACK RT-HM60-SK YB 221 K	16.090
C105-1	CAPACITOR MKT	22nF 10% 100VDC	PHILIPS	2222 370 88223	11.175
C106-1	CAPACITOR CERAMIC	10nF -20/+80% CL2 50VDC	KCK	AMMO PACK RT-HE70 SK YF 103 Z	15.170

POSITION	DESCRIPTION		MANUFACTOR	TYPE	S.P.NUMBER
C107-1	CAPACITOR MKT	220nF 20% 63VDC	ERO	MKT 1826-422/06 6-G	11.183
C108-1	CAPACITOR ELECTROLYTIC	100uF -10/+50% 25VDC	ERO	EKM 00 CC 310 E 65	14.610
C109-1	CAPACITOR MKT	1uF 5% 63VDC	PHILIPS	2222 370 79105	11.190
C110-1	CAPACITOR MKT	10nF 5% 63VDC	PHILIPS	2222 370 89103	11.134
C111-1	CAPACITOR MKT	10nF 5% 63VDC	PHILIPS	2222 370 89103	11.134
C112-1	CAPACITOR MKT	10nF 5% 63VDC	PHILIPS	2222 370 89103	11.134
C113-1	CAPACITOR MKT	1uF 5% 63VDC	PHILIPS	2222 370 79105	11.190
C114-1	CAPACITOR MKT	33nF 5% 100VDC	PHILIPS	2222 370 89333	11.176
C115-1	CAPACITOR MKT	33nF 5% 100VDC	PHILIPS	2222 370 89333	11.176
C116-1	CAPACITOR MKT	33nF 5% 100VDC	PHILIPS	2222 370 89333	11.176
C117-1	CAPACITOR POLYSTYRENE	2nF 1% 160V	#PHILIPS	2222 429 8200?	10.283
C118-1	CAPACITOR POLYSTYRENE	180pF 1% 630VDC	PHILIPS	2222 431 81801	10.407
C119-1	CAPACITOR ELECTROLYTIC	22uF 20% 25VDC	ELNA	RJ2-25-V-220-M-T34	14.514
C120-1	CAPACITOR POLYSTYRENE	240pF 1% 630VDC	PHILIPS	2222 431 82401	10.410
C121-1	CAPACITOR POLYSTYRENE	1n1F 1% 160VDC	PHILIPS	2222 429 81102	10.351
C122-1	CAPACITOR POLYSTYRENE	820pF 1% 250VDC	PHILIPS	2222 430 88201	10.348
C123-1	CAPACITOR MKT	330nF 10% 63VDC	PHILIPS	2222 370 78334	11.189
C124-1	CAPACITOR CERAMIC	10nF -20/+80% CL2 50VDC	KCK	RT-HE70 SK YF 103 Z AMMO PACK	15.170
C125-1	CAPACITOR CERAMIC	10nF -20/+80% CL2 50VDC	KCK	RT-HE70 SK YF 103 Z AMMO PACK	15.170
C126-1	CAPACITOR CERAMIC	10nF -20/+80% CL2 50VDC	KCK	RT-HE70 SK YF 103 Z AMMO PACK	15.170
C127-1	CAPACITOR CERAMIC	10nF -20/+80% CL2 50VDC	KCK	RT-HE70 SK YF 103 Z AMMO PACK	15.170
C128-1	CAPACITOR ELECTROLYTIC	22uF 20% 25VDC	ELNA	RJ2-25-V-220-M-T34	14.514
C129-1	CAPACITOR CERAMIC	10nF -20/+80% CL2 50VDC	KCK	RT-HE70 SK YF 103 Z AMMO PACK	15.170
C130-1	CAPACITOR CERAMIC	220pF 10% 500VDC CL2	KCK	RT-HM60-SK YB 221 K AMMO PACK	16.090
C131-1	CAPACITOR ELECTROLYTIC	22uF 20% 25VDC	ELNA	RJ2-25-V-220-M-T34	14.514
C132-1	CAPACITOR ELECTROLYTIC	22uF 20% 25VDC	ELNA	RJ2-25-V-220-M-T34	14.514
C133-1	CAPACITOR CERAMIC	10nF -20/+80% CL2 50VDC	KCK	RT-HE70 SK YF 103 Z AMMO PACK	15.170
C134-1	CAPACITOR CERAMIC	18pF 5% N150 50VDC	NKE	DT 340 758S PH 180 J 50V FLAT PACK	15.061
C135-1	CAPACITOR POLYSTYRENE	270pF 1% 630V	#PHILIPS	2222 431 82701	10.411
C136-1	CAPACITOR POLYSTYRENE	270pF 1% 630V	#PHILIPS	2222 431 82701	10.411
C137-1	CAPACITOR CERAMIC	10nF -20/+80% CL2 50VDC	KCK	RT-HE70 SK YF 103 Z AMMO PACK	15.170
C138-1	CAPACITOR CERAMIC	2p7F +/-0.25pF N150 50VDC	NKE	DT 330 758S PJ 2R7 C 50V FLAT PACK	15.001
C139-1	CAPACITOR CERAMIC	2p7F +/-0.25pF N150 50VDC	NKE	DT 330 758S PJ 2R7 C 50V FLAT PACK	15.001

POSITION	DESCRIPTION		MANUFACTOR	TYPE	S.P.NUMBER
C140-1	CAPACITOR CERAMIC	2p7F +/-0.25pF N150 50VDC	NKE	DT 330 758S PJ 2R7 C 50V FLAT PACK	15.001
C141-1	CAPACITOR CERAMIC	2p7F +/-0.25pF N150 50VDC	NKE	DT 330 758S PJ 2R7 C 50V FLAT PACK	15.001
C142-1	CAPACITOR MKT	1uF 5% 63VDC	PHILIPS	2222 370 79105	11.190
C144-1	CAPACITOR ELECTROLYTIC	22uF 20% 25VDC	ELNA	RJ2-25-V-220-M-T34	14.514
C145-1	CAPACITOR ELECTROLYTIC	22uF 20% 25VDC	ELNA	RJ2-25-V-220-M-T34	14.514
C146-1	CAPACITOR ELECTROLYTIC	22uF 20% 25VDC	ELNA	RJ2-25-V-220-M-T34	14.514
C147-1	CAPACITOR ELECTROLYTIC	22uF 20% 25VDC	ELNA	RJ2-25-V-220-M-T34	14.514
C148-1	CAPACITOR ELECTROLYTIC	22uF 20% 25VDC	ELNA	RJ2-25-V-220-M-T34	14.514
C149-1	CAPACITOR ELECTROLYTIC	22uF 20% 25VDC	ELNA	RJ2-25-V-220-M-T34	14.514
C150-1	CAPACITOR ELECTROLYTIC	10uF 20% 35VDC	ERO	EKI 00 AA 210 F M9	14.512
C151-1	CAPACITOR CERAMIC	10nF -20/+80% CL2 50VDC	KCK	RT-HE70 SK YF 103 Z AMMO PACK	15.170
C152-1	CAPACITOR ELECTROLYTIC	220uF -20/+50% 25VDC	ERO	EKM 05 DD 322 E 05	14.647
C154-1	CAPACITOR MKT	330nF 10% 63VDC	PHILIPS	2222 370 78334	11.189
C155-1	CAPACITOR MKT	220nF 20% 63VDC	ERO	MKT 1826-422/06 6-G	11.183
D1-1	DIODE HIGH SPEED	1N4448	PHILIPS	1N4448	25.146
D2-1	DIODE HIGH SPEED	1N4448	PHILIPS	1N4448	25.146
D3-1	DIODE HIGH SPEED	1N4448	PHILIPS	1N4448	25.146
D4-1	DIODE SWITCH	BA243	TFK	BA243	25.386
D5-1	DIODE SWITCH	BA243	TFK	BA243	25.386
D6-1	DIODE SWITCH	BA243	TFK	BA243	25.386
D7-1	DIODE SWITCH	BA243	TFK	BA243	25.386
D8-1	DIODE SWITCH	BA243	TFK	BA243	25.386
D9-1	DIODE	1N4148 HIGH SPEED	PHILIPS	1N4148-143	25.131
D10-1	DIODE	1N4148 HIGH SPEED	PHILIPS	1N4148-143	25.131
D11-1	DIODE	1N4148 HIGH SPEED	PHILIPS	1N4148-143	25.131
D12-1	DIODE	1N4148 HIGH SPEED	PHILIPS	1N4148-143	25.131
D13-1	DIODE	1N4148 HIGH SPEED	PHILIPS	1N4148-143	25.131
D14-1	DIODE	1N4148 HIGH SPEED	PHILIPS	1N4148-143	25.131
D15-1	DIODE	1N4148 HIGH SPEED	PHILIPS	1N4148-143	25.131
D16-1	DIODE	1N4148 HIGH SPEED	PHILIPS	1N4148-143	25.131
D17-1	DIODE SWITCH	BA243	TFK	BA243	25.386
D18-1	DIODE SWITCH	BA243	TFK	BA243	25.386
D19-1	DIODE SWITCH	BA243	TFK	BA243	25.386
D20-1	DIODE SWITCH	BA243	TFK	BA243	25.386
D21-1	DIODE	1N4148 HIGH SPEED	PHILIPS	1N4148-143	25.131
D22-1	DIODE	1N4148 HIGH SPEED	PHILIPS	1N4148-143	25.131
D23-1	DIODE	1N4148 HIGH SPEED	PHILIPS	1N4148-143	25.131
D26-1	DIODE	1N4148 HIGH SPEED	PHILIPS	1N4148-143	25.131
D27-1	DIODE	1N4148 HIGH SPEED	PHILIPS	1N4148-143	25.131
FL1-1	CRYSTAL FILTER	Fc=10.729995MHz	NDK	SP.SPEC: C1071C	40.033
FL2-1	CRYSTAL FILTER	Fc=10.731520MHz	NDK	SP.SPEC: C1070C	40.032

POSITION	DESCRIPTION		MANUFACTOR	TYPE	S.P. NUMBER
FL3-1	CERAMIC FILTER	Fc=10.7MHz +/-30kHz	MURATA	SFE 10.7 MS2-A	41.511
FP1-1	FERRITE BEAD INDUCTOR		MURATA	BL01RN1-A62T5	35.188
FP2-1	FERRITE BEAD INDUCTOR		MURATA	BL01RN1-A62T5	35.188
FP3-1	FERRITE BEAD	Ø3.7xØ1.2x3.5mm GRADE 4B1	PHILIPS	4322 020 34420	35.181
FP4-1	FERRITE BEAD	Ø3.7xØ1.2x3.5mm GRADE 4B1	PHILIPS	4322 020 34420	35.181
FP5-1	FERRITE BEAD	Ø3.7xØ1.2x3.5mm GRADE 4B1	PHILIPS	4322 020 34420	35.181
FP6-1	FERRITE BEAD	Ø3.7xØ1.2x3.5mm GRADE 4B1	PHILIPS	4322 020 34420	35.181
FP7-1	FERRITE BEAD INDUCTOR		MURATA	BL01RN1-A62T5	35.188
FP8-1	FERRITE BEAD	Ø3.7xØ1.2x3.5mm GRADE 4B1	PHILIPS	4322 020 34420	35.181
FP9-1	FERRITE BEAD INDUCTOR		MURATA	BL01RN1-A62T5	35.188
FP10-1	FERRITE BEAD	Ø3.7xØ1.2x3.5mm GRADE 4B1	PHILIPS	4322 020 34420	35.181
FP11-1	FERRITE BEAD INDUCTOR		MURATA	BL01RN1-A62T5	35.188
FP12-1	FERRITE BEAD INDUCTOR		MURATA	BL01RN1-A62T5	35.188
FP13-1	FERRITE BEAD	Ø3.7xØ1.2x3.5mm GRADE 4B1	PHILIPS	4322 020 34420	35.181
J1-1	SOCKET COAX	PCB MOUNT.	TAIKO	TMP-302X-A1	78.516
J2-1	SOCKET COAX	PCB MOUNT.	TAIKO	TMP-302X-A1	78.516
J3-1	SOCKET	2x3 POLES	AMP	0-215079-6	78.192
J4-1	SOCKET COAX	PCB MOUNT.	TAIKO	TMP-302X-A1	78.516
L1-1	CHOKE FIXED	100nH 10%	SIEMENS	B78108-T3101-K	20.335
L2-1	CHOKE FIXED	2u2H 10%	FASTRON	MICC-2R2K-02	20.351
L3-1	CHOKE FIXED	330nH 10%	FASTRON	MICC-R33K-02	20.341
L4-1	CHOKE FIXED	100nH 10%	SIEMENS	B78108-T3101-K	20.335
L6-1	CHOKE FIXED	2u2H 10%	FASTRON	MICC-2R2K-02	20.351
L7-1	CHOKE FIXED	2u2H 10%	FASTRON	MICC-2R2K-02	20.351
L8-1	CHOKE FIXED SHILDED	6u8H 10%	JEFFERS	1556R8K TAPED/AMMO PACK	20.143
L9-1	CHOKE FIXED SHILDED	6u8H 10%	JEFFERS	1556R8K TAPED/AMMO PACK	20.143
L10-1	CHOKE FIXED SHILDED	6u8H 10%	JEFFERS	1556R8K TAPED/AMMO PACK	20.143
L11-1	CHOKE FIXED SHILDED	6u8H 10%	JEFFERS	1556R8K TAPED/AMMO PACK	20.143
L13-1	CHOKE FIXED	2u2H 10%	FASTRON	MICC-2R2K-02	20.351
L14-1	CHOKE FIXED	470uH 5%	FASTRON	SMCC-471J-02	20.318
L15-1	CHOKE FIXED	2u2H 10%	FASTRON	MICC-2R2K-02	20.351
L16-1	CHOKE FIXED	470uH 5%	FASTRON	SMCC-471J-02	20.318
L17-1	CHOKE FIXED	2u2H 10%	FASTRON	MICC-2R2K-02	20.351
L18-1	CHOKE FIXED	470uH 5%	FASTRON	SMCC-471J-02	20.318
L19-1	CHOKE FIXED	2u2H 10%	FASTRON	MICC-2R2K-02	20.351
L20-1	CHOKE FIXED	470uH 5%	FASTRON	SMCC-471J-02	20.318
L22-1	CHOKE FIXED	2u2H 10%	FASTRON	MICC-2R2K-02	20.351
L23-1	CHOKE FIXED	2u2H 10%	FASTRON	MICC-2R2K-02	20.351
P1-1	PLUG	1/10" SIL SQ.PINS 3 POLES	EURO DIP	PH1-029/058-03-ZG075	78.323
P2-1	PLUG	2x7 POLES	3M	3598-6002	78.254
P3-1	PLUG	2x13 POLES	3M	3593-6002	78.248
P4-1	PLUG	1/10" SIL SQ.PINS 3 POLES	EURO DIP	PH1-029/058-03-ZG075	78.323
Q1-1	TRANSISTOR N-CHAN. JFET	TIS88A2	MOTOROLA	TM00 044-2	29.736
Q2-1	TRANSISTOR N-CHAN. JFET	TIS88A2	MOTOROLA	TM00 044-2	29.736

POSITION	DESCRIPTION		MANUFACTOR	TYPE	S.P. NUMBER
Q3-1	TRANSISTOR RF	BFW17A PNP T0-39	PHILIPS	BFW17A	29.151
Q4-1	TRANSISTOR AF	BC548 NPN T0-92	PHILIPS	BC548 (-A/-B/-C)	28.070
Q5-1	TRANSISTOR AF	BC548 NPN T0-92	PHILIPS	BC548 (-A/-B/-C)	28.070
Q6-1	TRANSISTOR AF	BC548 NPN T0-92	PHILIPS	BC548 (-A/-B/-C)	28.070
Q7-1	TRANSISTOR MOSFET	DUAL GATE N-CHAN.BF964SA	TFK	BF964SA	28.240
Q8-1	TRANSISTOR MOSFET	DUAL GATE N-CHAN.BF964SA	TFK	BF964SA	28.240
Q9-1	TRANSISTOR MOSFET	DUAL GATE N-CHAN.BF964SA	TFK	BF964SA	28.240
Q10-1	TRANSISTOR MOSFET	DUAL GATE N-CHAN.BF964SA	TFK	BF964SA	28.240
Q11-1	TRANSISTOR RF	BF199	PHILIPS	BF199	28.178
Q12-1	TRANSISTOR AF	BC548 NPN T0-92	PHILIPS	BC548 (-A/-B/-C)	28.070
Q13-1	TRANSISTOR AF	BC548 NPN T0-92	PHILIPS	BC548 (-A/-B/-C)	28.070
Q14-1	TRANSISTOR AF	BC558 PNP T0-92	PHILIPS	BC558 (-A/-B/-C)	28.095
Q15-1	TRANSISTOR AF	BC548 NPN T0-92	PHILIPS	BC548 (-A/-B/-C)	28.070
Q16-1	TRANSISTOR RF	BF199	PHILIPS	BF199	28.178
Q17-1	TRANSISTOR AF	BC548 NPN T0-92	PHILIPS	BC548 (-A/-B/-C)	28.070
Q18-1	TRANSISTOR AF	BC548 NPN T0-92	PHILIPS	BC548 (-A/-B/-C)	28.070
Q19-1	TRANSISTOR DARLINGTON	NPN BC618	MOTOROLA	BC618	28.107
Q20-1	TRANSISTOR AF	BC548 NPN T0-92	PHILIPS	BC548 (-A/-B/-C)	28.070
R1-1	RESISTOR MF	10k OHM 5% 0.33W	PHILIPS	2322 180 73103	02.496
R2-1	RESISTOR MF	470 OHM 5% 0.33W	PHILIPS	2322 180 73471	02.464
R3-1	RESISTOR MF	220 OHM 5% 0.33W	PHILIPS	2322 180 73221	02.456
R4-1	RESISTOR MF	430 OHM 5% 0.33W	PHILIPS	2322 180 73431	02.463
R5-1	RESISTOR MF	3k9 OHM 5% 0.33W	PHILIPS	2322 180 73392	02.486
R6-1	RESISTOR MF	33 OHM 5% 0.33W	PHILIPS	2322 180 73339	02.436
R7-1	RESISTOR MF	56 OHM 5% 0.33W	PHILIPS	2322 180 73569	02.442
R8-1	RESISTOR MF	120 OHM 5% 0.33W	PHILIPS	2322 180 73121	02.450
R9-1	RESISTOR MF	12 OHM 5% 0.33W	PHILIPS	2322 180 73129	02.426
R10-1	RESISTOR MF	3k9 OHM 5% 0.33W	PHILIPS	2322 180 73392	02.486
R11-1	RESISTOR MF	3k3 OHM 5% 0.33W	PHILIPS	2322 180 73332	02.484
R12-1	RESISTOR MF	100 OHM 5% 0.33W	PHILIPS	2322 180 73101	02.448
R13-1	RESISTOR MF	3k3 OHM 5% 0.33W	PHILIPS	2322 180 73332	02.484
R14-1	RESISTOR MF	10k OHM 5% 0.33W	PHILIPS	2322 180 73103	02.496
R15-1	RESISTOR MF	10k OHM 5% 0.33W	PHILIPS	2322 180 73103	02.496
R16-1	RESISTOR MF	5k6 OHM 5% 0.33W	PHILIPS	2322 180 73562	02.490
R17-1	RESISTOR MF	1k0 OHM 5% 0.33W	PHILIPS	2322 180 73102	02.472
R18-1	RESISTOR MF	27k OHM 5% 0.33W	PHILIPS	2322 180 73273	02.506
R19-1	RESISTOR MF	2k7 OHM 5% 0.33W	PHILIPS	2322 180 73272	02.482
R20-1	RESISTOR MF	1k5 OHM 5% 0.33W	PHILIPS	2322 180 73152	02.476
R21-1	RESISTOR MF	1k0 OHM 5% 0.33W	PHILIPS	2322 180 73102	02.472
R22-1	RESISTOR MF	1k5 OHM 5% 0.33W	PHILIPS	2322 180 73152	02.476
R23-1	RESISTOR MF	1k0 OHM 5% 0.33W	PHILIPS	2322 180 73102	02.472
R24-1	RESISTOR MF	2k2 OHM 5% 0.33W	PHILIPS	2322 180 73222	02.480
R25-1	RESISTOR MF	18k OHM 5% 0.33W	PHILIPS	2322 180 73183	02.502
R26-1	RESISTOR MF	4k7 OHM 5% 0.33W	PHILIPS	2322 180 73472	02.488



POSITION	DESCRIPTION		MANUFACTOR	TYPE	S.P. NUMBER
R27-1	RESISTOR MF	820 OHM 5% 0.33W	PHILIPS	2322 180 73821	02.470
R28-1	RESISTOR MF	100 OHM 5% 0.33W	PHILIPS	2322 180 73101	02.448
R29-1	RESISTOR MF	390 OHM 5% 0.33W	PHILIPS	2322 180 73391	02.462
R30-1	RESISTOR MF	10k OHM 5% 0.33W	PHILIPS	2322 180 73103	02.496
R31-1	RESISTOR MF	2k7 OHM 5% 0.33W	PHILIPS	2322 180 73272	02.482
R32-1	RESISTOR MF	820 OHM 5% 0.33W	PHILIPS	2322 180 73821	02.470
R33-1	RESISTOR MF	100 OHM 5% 0.33W	PHILIPS	2322 180 73101	02.448
R34-1	RESISTOR MF	390 OHM 5% 0.33W	PHILIPS	2322 180 73391	02.462
R35-1	RESISTOR MF	10k OHM 5% 0.33W	PHILIPS	2322 180 73103	02.496
R36-1	RESISTOR MF	2k7 OHM 5% 0.33W	PHILIPS	2322 180 73272	02.482
R37-1	RESISTOR MF	820 OHM 5% 0.33W	PHILIPS	2322 180 73821	02.470
R38-1	RESISTOR MF	100 OHM 5% 0.33W	PHILIPS	2322 180 73101	02.448
R39-1	RESISTOR MF	390 OHM 5% 0.33W	PHILIPS	2322 180 73391	02.462
R40-1	RESISTOR MF	10k OHM 5% 0.33W	PHILIPS	2322 180 73103	02.496
R41-1	RESISTOR MF	2k7 OHM 5% 0.33W	PHILIPS	2322 180 73272	02.482
R42-1	RESISTOR MF	4k7 OHM 5% 0.33W	PHILIPS	2322 180 73472	02.488
R43-1	RESISTOR MF	22k OHM 5% 0.33W	PHILIPS	2322 180 73223	02.504
R44-1	RESISTOR MF	100 OHM 5% 0.33W	PHILIPS	2322 180 73101	02.448
R45-1	RESISTOR MF	330 OHM 5% 0.33W	PHILIPS	2322 180 73331	02.460
R46-1	RESISTOR MF	390 OHM 5% 0.33W	PHILIPS	2322 180 73391	02.462
R47-1	RESISTOR MF	330 OHM 5% 0.33W	PHILIPS	2322 180 73331	02.460
R48-1	RESISTOR MF	8k2 OHM 5% 0.33W	PHILIPS	2322 180 73822	02.494
R49-1	RESISTOR MF	6k8 OHM 5% 0.33W	PHILIPS	2322 180 73682	02.492
R50-1	RESISTOR MF	100 OHM 5% 0.33W	PHILIPS	2322 180 73101	02.448
R51-1	RESISTOR MF	1k8 OHM 5% 0.33W	PHILIPS	2322 180 73182	02.478
R52-1	PRESET CERMET	10k OHM 10% 0.5W	BOURNS	3386P-1-103	07.889
R53-1	RESISTOR MF	100 OHM 5% 0.33W	PHILIPS	2322 180 73101	02.448
R54-1	RESISTOR MF	100 OHM 5% 0.33W	PHILIPS	2322 180 73101	02.448
R55-1	RESISTOR MF	100 OHM 5% 0.33W	PHILIPS	2322 180 73101	02.448
R56-1	RESISTOR MF	100 OHM 5% 0.33W	PHILIPS	2322 180 73101	02.448
R57-1	RESISTOR MF	820 OHM 5% 0.33W	PHILIPS	2322 180 73821	02.470
R59-1	RESISTOR MF	1k0 OHM 5% 0.33W	PHILIPS	2322 180 73102	02.472
R60-1	RESISTOR MF	15k OHM 5% 0.33W	PHILIPS	2322 180 73153	02.500
R61-1	RESISTOR MF	10 OHM 5% 0.33W	PHILIPS	2322 180 73109	02.424
R62-1	RESISTOR MF	100 OHM 5% 0.33W	PHILIPS	2322 180 73101	02.448
R63-1	RESISTOR MF	680k OHM 5% 0.33W	PHILIPS	2322 180 73684	02.540
R64-1	RESISTOR MF	3k9 OHM 5% 0.33W	PHILIPS	2322 180 73392	02.486
R65-1	RESISTOR MF	15k OHM 5% 0.33W	PHILIPS	2322 180 73153	02.500
R66-1	RESISTOR MF	4k7 OHM 5% 0.33W	PHILIPS	2322 180 73472	02.488
R67-1	RESISTOR MF	15k OHM 5% 0.33W	PHILIPS	2322 180 73153	02.500
R68-1	RESISTOR MF	12k OHM 5% 0.33W	PHILIPS	2322 180 73123	02.498
R69-1	RESISTOR MF	56k OHM 5% 0.33W	PHILIPS	2322 180 73563	02.514
R70-1	RESISTOR MF	100k OHM 5% 0.33W	PHILIPS	2322 180 73104	02.520
R71-1	RESISTOR MF	1k0 OHM 5% 0.33W	PHILIPS	2322 180 73102	02.472

POSITION	DESCRIPTION		MANUFACTOR	TYPE	S.P. NUMBER
R72-1	RESISTOR MF	27k OHM 5% 0.33W	PHILIPS	2322 180 73273	02.506
R73-1	RESISTOR MF	10k OHM 5% 0.33W	PHILIPS	2322 180 73103	02.496
R74-1	RESISTOR MF	10k OHM 5% 0.33W	PHILIPS	2322 180 73103	02.496
R75-1	RESISTOR MF	8k2 OHM 5% 0.33W	PHILIPS	2322 180 73822	02.494
R76-1	PRESET CERMET	1k0 OHM 10% 0.5W	BOURNS	3386P-1-102	07.886
R77-1	RESISTOR MF	3k3 OHM 5% 0.33W	PHILIPS	2322 180 73332	02.484
R78-1	RESISTOR MF	7k5 OHM 5% 0.33W	PHILIPS	2322 180 73752	02.493
R79-1	RESISTOR MF	100k OHM 5% 0.33W	PHILIPS	2322 180 73104	02.520
R80-1	RESISTOR MF	100k OHM 5% 0.33W	PHILIPS	2322 180 73104	02.520
R81-1	RESISTOR MF	100k OHM 5% 0.33W	PHILIPS	2322 180 73104	02.520
R82-1	RESISTOR MF	100k OHM 5% 0.33W	PHILIPS	2322 180 73104	02.520
R83-1	RESISTOR MF	22k OHM 5% 0.33W	PHILIPS	2322 180 73223	02.504
R84-1	RESISTOR MF	22k OHM 5% 0.33W	PHILIPS	2322 180 73223	02.504
R85-1	RESISTOR MF	68k OHM 5% 0.33W	PHILIPS	2322 180 73683	02.516
R86-1	RESISTOR MF	22k OHM 5% 0.33W	PHILIPS	2322 180 73223	02.504
R87-1	RESISTOR MF	22k OHM 5% 0.33W	PHILIPS	2322 180 73223	02.504
R88-1	RESISTOR MF	100k OHM 5% 0.33W	PHILIPS	2322 180 73104	02.520
R89-1	RESISTOR MF	15k OHM 5% 0.33W	PHILIPS	2322 180 73153	02.500
R90-1	RESISTOR MF	100 OHM 5% 0.33W	PHILIPS	2322 180 73101	02.448
R91-1	RESISTOR MF	22k OHM 5% 0.33W	PHILIPS	2322 180 73223	02.504
R92-1	RESISTOR MF	10k OHM 5% 0.33W	PHILIPS	2322 180 73103	02.496
R93-1	RESISTOR MF	100 OHM 5% 0.33W	PHILIPS	2322 180 73101	02.448
R94-1	RESISTOR MF	680 OHM 5% 0.33W	PHILIPS	2322 180 73681	02.468
R95-1	RESISTOR MF	10k OHM 5% 0.33W	PHILIPS	2322 180 73103	02.496
R96-1	RESISTOR MF	10k OHM 5% 0.33W	PHILIPS	2322 180 73103	02.496
R97-1	RESISTOR MF	1k0 OHM 5% 0.33W	PHILIPS	2322 180 73102	02.472
R98-1	RESISTOR MF	47 OHM 5% 0.33W	PHILIPS	2322 180 73479	02.440
R99-1	RESISTOR MF	47 OHM 5% 0.33W	PHILIPS	2322 180 73479	02.440
R100-1	RESISTOR MF	10k OHM 5% 0.33W	PHILIPS	2322 180 73103	02.496
R101-1	RESISTOR MF	10k OHM 5% 0.33W	PHILIPS	2322 180 73103	02.496
R102-1	RESISTOR MF	4k3 OHM 5% 0.33W	PHILIPS	2322 180 73432	02.487
R103-1	RESISTOR MF	330 OHM 5% 0.33W	PHILIPS	2322 180 73331	02.460
R104-1	RESISTOR MF	620 OHM 5% 0.33W	PHILIPS	2322 180 73621	02.467
R105-1	RESISTOR MF	47 OHM 5% 0.33W	PHILIPS	2322 180 73479	02.440
R106-1	RESISTOR MF	100 OHM 5% 0.33W	PHILIPS	2322 180 73101	02.448
R107-1	RESISTOR MF	5k6 OHM 5% 0.33W	PHILIPS	2322 180 73562	02.490
R108-1	RESISTOR MF	1k2 OHM 5% 0.33W	PHILIPS	2322 180 73122	02.474
R109-1	RESISTOR MF	2k7 OHM 5% 0.33W	PHILIPS	2322 180 73272	02.482
R110-1	RESISTOR MF	560 OHM 5% 0.33W	PHILIPS	2322 180 73561	02.466
R111-1	RESISTOR MF	100k OHM 5% 0.33W	PHILIPS	2322 180 73104	02.520
R112-1	RESISTOR MF	10k OHM 5% 0.33W	PHILIPS	2322 180 73103	02.496
R113-1	RESISTOR MF	50k OHM 5% 0.33W	PHILIPS	2322 180 73513	02.513
R114-1	RESISTOR MF	100 OHM 5% 0.33W	PHILIPS	2322 180 73101	02.448
R115-1	RESISTOR MF	100 OHM 5% 0.33W	PHILIPS	2322 180 73101	02.448

POSITION	DESCRIPTION	MANUFACTURER	TYPE	S.P. NUMBER	
R116-1	RESISTOR MF	100 OHM 5% 0.33W	PHILIPS	2322 180 73101	02.448
R117-1	RESISTOR MF	12k OHM 5% 0.33W	PHILIPS	2322 180 73123	02.498
R118-1	RESISTOR MF	12k OHM 5% 0.33W	PHILIPS	2322 180 73123	02.498
R119-1	RESISTOR MF	470k OHM 5% 0.33W	PHILIPS	2322 180 73474	02.536
R120-1	RESISTOR MF	100 OHM 5% 0.33W	PHILIPS	2322 180 73101	02.448
R121-1	RESISTOR MF	12k OHM 5% 0.33W	PHILIPS	2322 180 73123	02.498
R122-1	RESISTOR MF	100k OHM 5% 0.33W	PHILIPS	2322 180 73104	02.520
R123-1	RESISTOR MF	100k OHM 5% 0.33W	PHILIPS	2322 180 73104	02.520
R124-1	RESISTOR MF	1k0 OHM 5% 0.33W	PHILIPS	2322 180 73102	02.472
R125-1	RESISTOR MF	100k OHM 5% 0.33W	PHILIPS	2322 180 73104	02.520
R126-1	RESISTOR MF	1M OHM 5% 0.33W	PHILIPS	2322 180 73105	02.544
R127-1	RESISTOR MF	4k53 OHM 1% 0.25W	PHILIPS	2322 157 14532	02.219
R128-1	RESISTOR MF	18k2 OHM 1% 0.25W	PHILIPS	2322 157 11823	02.233
R129-1	RESISTOR MF	12k OHM 5% 0.33W	PHILIPS	2322 180 73123	02.498
R130-1	RESISTOR MF	10k OHM 5% 0.33W	PHILIPS	2322 180 73103	02.496
R131-1	RESISTOR MF	3k9 OHM 5% 0.33W	PHILIPS	2322 180 73392	02.486
R132-1	RESISTOR MF	560 OHM 5% 0.33W	PHILIPS	2322 180 73561	02.466
R133-1	RESISTOR MF	100k OHM 5% 0.33W	PHILIPS	2322 180 73104	02.520
R134-1	RESISTOR MF	100k OHM 5% 0.33W	PHILIPS	2322 180 73104	02.520
R135-1	RESISTOR MF	100k OHM 5% 0.33W	PHILIPS	2322 180 73104	02.520
R136-1	RESISTOR MF	11k5 OHM 1% 0.25W	PHILIPS	2322 157 11153	02.230
R137-1	RESISTOR MF	11k5 OHM 1% 0.25W	PHILIPS	2322 157 11153	02.230
R138-1	RESISTOR MF	100k OHM 5% 0.33W	PHILIPS	2322 180 73104	02.520
R139-1	RESISTOR MF	820k OHM 5% 0.33W	PHILIPS	2322 180 73824	02.542
R140-1	RESISTOR MF	100 OHM 5% 0.33W	PHILIPS	2322 180 73101	02.448
R141-1	RESISTOR MF	39k OHM 5% 0.33W	PHILIPS	2322 180 73393	02.510
R142-1	RESISTOR MF	39k OHM 5% 0.33W	PHILIPS	2322 180 73393	02.510
R143-1	RESISTOR MF	1M OHM 5% 0.33W	PHILIPS	2322 180 73105	02.544
R144-1	RESISTOR MF	100k OHM 5% 0.33W	PHILIPS	2322 180 73104	02.520
R145-1	RESISTOR MF	2k7 OHM 5% 0.33W	PHILIPS	2322 180 73272	02.482
R146-1	RESISTOR MF	100k OHM 5% 0.33W	PHILIPS	2322 180 73104	02.520
R147-1	RESISTOR MF	2k7 OHM 5% 0.33W	PHILIPS	2322 180 73272	02.482
R148-1	RESISTOR MF	470k OHM 5% 0.33W	PHILIPS	2322 180 73474	02.536
R149-1	RESISTOR MF	470k OHM 5% 0.33W	PHILIPS	2322 180 73474	02.536
R150-1	RESISTOR MF	680 OHM 5% 0.33W	PHILIPS	2322 180 73681	02.468
R151-1	RESISTOR MF	15k OHM 5% 0.33W	PHILIPS	2322 180 73153	02.500
R152-1	RESISTOR MF	15k OHM 5% 0.33W	PHILIPS	2322 180 73153	02.500
R153-1	RESISTOR MF	470k OHM 5% 0.33W	PHILIPS	2322 180 73474	02.536
R154-1	RESISTOR MF	470k OHM 5% 0.33W	PHILIPS	2322 180 73474	02.536
R155-1	RESISTOR MF	39k OHM 5% 0.33W	PHILIPS	2322 180 73393	02.510
R156-1	RESISTOR MF	1k2 OHM 5% 0.33W	PHILIPS	2322 180 73122	02.474
R157-1	RESISTOR MF	2k2 OHM 5% 0.33W	PHILIPS	2322 180 73222	02.480
R158-1	RESISTOR MF	680k OHM 5% 0.33W	PHILIPS	2322 180 73684	02.540
R159-1	RESISTOR MF	680k OHM 5% 0.33W	PHILIPS	2322 180 73684	02.540

POSITION	DESCRIPTION	MANUFACTURER	TYPE	S.P. NUMBER	
R160-1	RESISTOR MF	20k OHM 5% 0.33W	PHILIPS	2322 180 73203	02.503
R161-1	RESISTOR MF	47k OHM 5% 0.33W	PHILIPS	2322 180 73473	02.512
R162-1	RESISTOR MF	15k OHM 5% 0.33W	PHILIPS	2322 180 73153	02.500
R163-1	RESISTOR MF	91k OHM 5% 0.33W	PHILIPS	2322 180 73913	02.519
R164-1	RESISTOR MF	91k OHM 5% 0.33W	PHILIPS	2322 180 73913	02.519
R165-1	RESISTOR MF	15k OHM 5% 0.33W	PHILIPS	2322 180 73153	02.500
R166-1	RESISTOR MF	100 OHM 5% 0.33W	PHILIPS	2322 180 73101	02.448
R167-1	RESISTOR MF	91k OHM 5% 0.33W	PHILIPS	2322 180 73913	02.519
R168-1	RESISTOR MF	91k OHM 5% 0.33W	PHILIPS	2322 180 73913	02.519
R169-1	RESISTOR MF	10k OHM 5% 0.33W	PHILIPS	2322 180 73103	02.496
R170-1	RESISTOR MF	1M OHM 5% 0.33W	PHILIPS	2322 180 73105	02.544
R171-1	RESISTOR MF	100 OHM 5% 0.33W	PHILIPS	2322 180 73101	02.448
R172-1	RESISTOR MF	15k OHM 5% 0.33W	PHILIPS	2322 180 73153	02.500
R173-1	RESISTOR MF	15k OHM 5% 0.33W	PHILIPS	2322 180 73153	02.500
R174-1	RESISTOR MF	100 OHM 5% 0.33W	PHILIPS	2322 180 73101	02.448
R175-1	RESISTOR MF	100 OHM 5% 0.33W	PHILIPS	2322 180 73101	02.448
R176-1	RESISTOR MF	100k OHM 5% 0.33W	PHILIPS	2322 180 73104	02.520
R177-1	RESISTOR MF	100 OHM 5% 0.33W	PHILIPS	2322 180 73101	02.448
R178-1	RESISTOR MF	1k8 OHM 5% 0.33W	PHILIPS	2322 180 73182	02.478
R179-1	RESISTOR MF	100 OHM 5% 0.33W	PHILIPS	2322 180 73101	02.448
R180-1	RESISTOR MF	100k OHM 5% 0.33W	PHILIPS	2322 180 73104	02.520
R181-1	RESISTOR MF	1k0 OHM 5% 0.33W	PHILIPS	2322 180 73102	02.472
R182-1	RESISTOR MF	100k OHM 5% 0.33W	PHILIPS	2322 180 73104	02.520
R183-1	RESISTOR MF	100k OHM 5% 0.33W	PHILIPS	2322 180 73104	02.520
R184-1	RESISTOR MF	82k OHM 5% 0.33W	PHILIPS	2322 180 73823	02.518
R185-1	RESISTOR MF	100 OHM 5% 0.33W	PHILIPS	2322 180 73101	02.448
R186-1	RESISTOR MF	1R OHM 5% 0.33W	PHILIPS	2322 180 73189	02.430
R187-1	RESISTOR MF	120 OHM 5% 0.33W	PHILIPS	2322 180 73121	02.450
R188-1	RESISTOR MF	120 OHM 5% 0.33W	PHILIPS	2322 180 73121	02.450
R189-1	RESISTOR MF	2k2 OHM 5% 0.33W	PHILIPS	2322 180 73222	02.480
R190-1	RESISTOR MF	1k0 OHM 5% 0.33W	PHILIPS	2322 180 73102	02.472
R191-1	RESISTOR MF	6k8 OHM 5% 0.33W	PHILIPS	2322 180 73682	02.492
R192-1	RESISTOR MF	1k5 OHM 5% 0.33W	PHILIPS	2322 180 73152	02.476
R193-1	RESISTOR MF	100 OHM 5% 0.33W	PHILIPS	2322 180 73101	02.448
R194-1	RESISTOR MF	100 OHM 5% 0.33W	PHILIPS	2322 180 73101	02.448
R195-1	RESISTOR MF	100 OHM 5% 0.33W	PHILIPS	2322 180 73101	02.448
R196-1	RESISTOR MF	100 OHM 5% 0.33W	PHILIPS	2322 180 73101	02.448
R197-1	RESISTOR MF	100 OHM 5% 0.33W	PHILIPS	2322 180 73101	02.448
R198-1	RESISTOR MF	100 OHM 5% 0.33W	PHILIPS	2322 180 73101	02.448
R199-1	RESISTOR MF	68k OHM 5% 0.33W	PHILIPS	2322 180 73683	02.516
R200-1	RESISTOR MF	27k OHM 5% 0.33W	PHILIPS	2322 180 73273	02.506
R201-1	RESISTOR MF	220 OHM 5% 0.33W	PHILIPS	2322 180 73221	02.456
R202-1	RESISTOR MF	330 OHM 5% 0.33W	PHILIPS	2322 180 73331	02.460
R203-1	PRESET CERMET	5k0 OHM 10% 0.5W	BOURNS	3386P-1-502	07.888

POSITION	DESCRIPTION		MANUFACTOR	TYPE	S.P. NUMBER
R204-1	RESISTOR MF	100 OHM 5% 0.33W	PHILIPS	2322 180 73101	02.448
R205-1	RESISTOR MF	100 OHM 5% 0.33W	PHILIPS	2322 180 73101	02.448
R206-1	RESISTOR MF	100 OHM 5% 0.33W	PHILIPS	2322 180 73101	02.448
R207-1	RESISTOR MF	100 OHM 5% 0.33W	PHILIPS	2322 180 73101	02.448
R208-1	RESISTOR MF	100 OHM 5% 0.33W	PHILIPS	2322 180 73101	02.448
R209-1	RESISTOR MF	100k OHM 5% 0.33W	PHILIPS	2322 180 73104	02.520
R210-1	RESISTOR MF	10k OHM 5% 0.33W	PHILIPS	2322 180 73103	02.496
R211-1	RESISTOR MF	10k OHM 5% 0.33W	PHILIPS	2322 180 73103	02.496
R212-1	RESISTOR MF	10k OHM 5% 0.33W	PHILIPS	2322 180 73103	02.496
R213-1	RESISTOR MF	10k OHM 5% 0.33W	PHILIPS	2322 180 73103	02.496
R214-1	RESISTOR MF	1k0 OHM 5% 0.33W	PHILIPS	2322 180 73102	02.472
R215-1	RESISTOR MF	10 OHM 5% 0.33W	PHILIPS	2322 180 73109	02.424
TR1-1	TRANSFORMER	ADJUSTABLE Fr=70MHz	MITSUMI	L-2M7-D3/DM-7141	38.438
TR2-1	COIL	TL407	ESPERA	6-0-24246A	400407
TR3-1	TRANSFORMER	TL492	S.P.RADIO	6-0-25811	400492
U1-1	QUAD OP.AMP.	324	TEXAS	LM324N	31.065
U2-1	QUAD OP.AMP.	324	TEXAS	LM324N	31.065
U3-1	QUAD OP.AMP.	324	TEXAS	LM324N	31.065
U4-1	QUAD OP.AMP.	324	TEXAS	LM324N	31.065
U5-1	FM IF SYSTEM	3189	NATIONAL	LM3189N	31.752
U6-1	DUAL AF POW.AMPLIFIER	LM831N	NATIONAL	LM831N	31.431
U7-1	ANALOG MULTIPLEXER	MC14053BCP	SIGNETICS*	HEF 4053 BP	33.201
U8-1	ANALOG MULTIPLEXER	MC14053BCP	SIGNETICS*	HEF 4053 BP	33.201
U9-1	ANALOG MULTIPLEXER	MC14053BCP	SIGNETICS*	HEF 4053 BP	33.201
U10-1	INTEGRATED CIRCUIT	8 BIT SHIFT REG.SERIAL IO	NATIONAL	MM74HC595N	34.502
U11-1	INTEGRATED CIRCUIT	8 BIT SHIFT REG.SERIAL IO	NATIONAL	MM74HC595N	34.502
U12-1	VOLTAGE REGULATOR	-5VOLT 5% 0.1A.	NATIONAL	LM79L05ACZ	31.131

POSITION	DESCRIPTION	RE2100	MANUFACTURER	TYPE	S.P. NUMBER
	Rx FRONT END MODULE 2	RE2100	ESPERA	5-0-256326	625632
VARIOUS	DISTANCE DISC	T0-5	RADIO PARTS	R.P.Nr: 316310	30.556
C2-2	CAPACITOR MKT	1uF 5% 63VDC	PHILIPS	2222 370 79105	11.190
C3-2	CAPACITOR CERAMIC	470pF 10% 500VDC	KCK	RT-HM60 SK YB 471 K AMMO PACK	16.095
C4-2	CAPACITOR CERAMIC	470pF 10% 500VDC	KCK	RT-HM60 SK YB 471 K AMMO PACK	16.095
C5-2	CAPACITOR MKT	1uF 5% 63VDC	PHILIPS	2222 370 79105	11.190
C6-2	CAPACITOR MKT	0.1uF 10% 63VDC	PHILIPS	2222 370 78104	11.136
C7-2	CAPACITOR ELECTROLYTIC	10uF 20% 35VDC	ERO	EKI 00 AA 210 F M9	14.512
C8-2	CAPACITOR MKT	22nF 5% 250VDC	PHILIPS	2222 371 49223	11.174
C9-2	CAPACITOR MKT	1uF 5% 63VDC	PHILIPS	2222 370 79105	11.190
C10-2	CAPACITOR CERAMIC	10nF -20/+80% CL2 50VDC	KCK	RT-HE70 SK YF 103 Z AMMO PACK	15.170
C11-2	CAPACITOR CERAMIC	10nF -20/+80% CL2 50VDC	KCK	RT-HE70 SK YF 103 Z AMMO PACK	15.170
C12-2	CAPACITOR CERAMIC	10nF -20/+80% CL2 50VDC	KCK	RT-HE70 SK YF 103 Z AMMO PACK	15.170
C13-2	CAPACITOR MKT	1uF 5% 63VDC	PHILIPS	2222 370 79105	11.190
C17-2	CAPACITOR CERAMIC	10nF -20/+80% CL2 50VDC	KCK	RT-HE70 SK YF 103 Z AMMO PACK	15.170
C18-2	CAPACITOR CERAMIC	120pF 2% N150 100VDC	PHILIPS	2222 683 34121	15.143
C19-2	CAPACITOR CERAMIC	68pF 2% N150 100VDC	PHILIPS	2222 683 34689	15.120
C20-2	CAPACITOR CERAMIC	120pF 2% N150 100VDC	PHILIPS	2222 683 34121	15.143
C21-2	CAPACITOR CERAMIC	10nF -20/+80% CL2 50VDC	KCK	RT-HE70 SK YF 103 Z AMMO PACK	15.170
C22-2	CAPACITOR CERAMIC	10nF -20/+80% CL2 50VDC	KCK	RT-HE70 SK YF 103 Z AMMO PACK	15.170
C23-2	CAPACITOR CERAMIC	10nF -20/+80% CL2 50VDC	KCK	RT-HE70 SK YF 103 Z AMMO PACK	15.170
C24-2	CAPACITOR POLYSTYRENE	200pF 1% 630VDC	PHILIPS	2222 431 82001	10.408
C25-2	CAPACITOR POLYSTERENE	150pF 1% 630VDC	PHILIPS	2222 431 81501	10.405
C26-2	CAPACITOR POLYSTYRENE	200pF 1% 630VDC	PHILIPS	2222 431 82001	10.408
C27-2	CAPACITOR CERAMIC	10nF -20/+80% CL2 50VDC	KCK	RT-HF70 SK YF 103 Z AMMO PACK	15.170
C28-2	CAPACITOR CERAMIC	10nF -20/+80% CL2 50VDC	KCK	RT-HE70 SK YF 103 Z AMMO PACK	15.170
C29-2	CAPACITOR CERAMIC	10nF -20/+80% CL2 50VDC	KCK	RT-HE70 SK YF 103 Z AMMO PACK	15.170
C30-2	CAPACITOR POLYSTYRENE	430pF 1% 630VDC	PHILIPS	2222 431 84301	10.428
C31-2	CAPACITOR POLYSTYRENE	300pF 1% 630VDC	PHILIPS	2222 431 83001	10.414
C32-2	CAPACITOR POLYSTYRENE	430pF 1% 630VDC	PHILIPS	2222 431 84301	10.428

POSITION	DESCRIPTION	RE2100	MANUFACTURER	TYPE	S.P. NUMBER
C33-2	CAPACITOR CERAMIC	10nF -20/+80% CL2 50VDC	KCK	RT-HE70 SK YF 103 Z AMMO PACK	15.170
C34-2	CAPACITOR CERAMIC	10nF -20/+80% CL2 50VDC	KCK	RT-HE70 SK YF 103 Z AMMO PACK	15.170
C35-2	CAPACITOR MKT	0.1uF 10% 63VDC	PHILIPS	2222 370 78104	11.136
C36-2	CAPACITOR POLYSTYRENE	750pF 1% 250VDC	PHILIPS	2222 430 87501	10.347
C37-2	CAPACITOR POLYSTYRENE	1n00F 1% 250VDC	PHILIPS	2222 430 81002	10.350
C38-2	CAPACITOR POLYSTYRENE	750pF 1% 250VDC	PHILIPS	2222 430 87501	10.347
C39-2	CAPACITOR MKT	0.1uF 10% 63VDC	PHILIPS	2222 370 78104	11.136
C40-2	CAPACITOR MKT	0.1uF 10% 63VDC	PHILIPS	2222 370 78104	11.136
C41-2	CAPACITOR MKT	470nF 5% 63VDC	PHILIPS	2222 370 79474	11.187
C42-2	CAPACITOR POLYSTYRENE	1n80F 1% 160VDC	PHILIPS	2222 429 81802	10.282
C43-2	CAPACITOR POLYSTERENE	4n70F 1% 63VDC	PHILIPS	2222 428 84702	10.217
C44-2	CAPACITOR POLYSTYRENE	1n80F 1% 160VDC	PHILIPS	2222 429 81802	10.282
C45-2	CAPACITOR MKT	470nF 5% 63VDC	PHILIPS	2222 370 79474	11.187
C46-2	CAPACITOR MKT	470nF 5% 63VDC	PHILIPS	2222 370 79474	11.187
C47-2	CAPACITOR MKT	470nF 5% 63VDC	PHILIPS	2222 370 79474	11.187
C48-2	CAPACITOR MKT	470nF 5% 63VDC	PHILIPS	2222 370 79474	11.187
C49-2	CAPACITOR POLYSTYRENE	6n20F 1% 63VDC	PHILIPS	2322 428 86202	10.220
C50-2	CAPACITOR POLYSTYRENE	6n20F 1% 63VDC	PHILIPS	2322 428 86202	10.220
C51-2	CAPACITOR MKT	0.1uF 10% 63VDC	PHILIPS	2222 370 78104	11.136
C52-2	CAPACITOR MKT	470nF 5% 63VDC	PHILIPS	2222 370 79474	11.187
C53-2	CAPACITOR MKT	1uF 5% 63VDC	PHILIPS	2222 370 79105	11.190
C54-2	CAPACITOR CERAMIC	120pF 2% N150 100VDC	PHILIPS	2222 683 34121	15.143
C55-2	CAPACITOR CERAMIC	120pF 2% N150 100VDC	PHILIPS	2222 683 34121	15.143
C56-2	CAPACITOR CERAMIC	47pF 2% N150	PHILIPS	2322 683 34479	15.102
C57-2	CAPACITOR CERAMIC	4n7F 20% CL2 50VDC	NKE	DT 380 758S D 472 M 50V FLAT PACK	15.165
C58-2	CAPACITOR CERAMIC	4n7F 20% CL2 50VDC	NKE	DT 380 758S D 472 M 50V FLAT PACK	15.165
C59-2	CAPACITOR CERAMIC	4p7F +/-0.25pF N750 50VDC	NKE	DT 330 758S UJ 4R7 C 50V FLAT PACK	15.872
C60-2	CAPACITOR MKT	22nF 10% 100VDC	PHILIPS	2222 370 88223	11.175
C61-2	CAPACITOR CERAMIC	5p0F +/-0.25pF N470 50VDC	NKE	DT 330 758S TH 5R0 C 50V FLAT PACK	15.847
C62-2	CAPACITOR CERAMIC	10nF -20/+80% CL2 50VDC	KCK	RT-HE70 SK YF 103 Z AMMO PACK	15.170
C63-2	CAPACITOR CERAMIC	10pF +/-0.5pF N150 50VDC	NKE	DT 340 758S PH 100 D 50V FLAT PACK	15.035
C64-2	CAPACITOR CERAMIC	47pF 5% N150 50VDC	KCK	RT-HE60-SK PH 470 J AMMO PACK	15.100
C65-2	CAPACITOR CERAMIC	6p8F +/-0.5pF N150 50VDC	NKE	DT 330 758S PH 6R8 D 50V FLAT PACK	15.020
C66-2	CAPACITOR CERAMIC	18pF 5% N150 50VDC	NKE	DT 340 758S PH 180 J 50V	15.061

POSITION	DESCRIPTION		MANUFACTOR	TYPE	S.P. NUMBER
C67-2	CAPACITOR CERAMIC	10pF +/-0.5pF N150 50VDC	NKE	FLAT PACK DT 340 758S PH 100 D 50V	15.035
C68-2	CAPACITOR CERAMIC	470pF 10% 500VDC	KCK	FLAT PACK RT-HM60 SK YB 471 K	16.095
C69-2	CAPACITOR CERAMIC	470pF 10% 500VDC	KCK	AMMO PACK RT-HM60 SK YB 471 K	16.095
C70-2	CAPACITOR MKT	0.1uF 10% 63VDC	PHILIPS	2222 370 78104	11.136
C71-2	CAPACITOR CERAMIC	470pF 10% 500VDC	KCK	RT-HM60 SK YB 471 K	16.095
C72-2	CAPACITOR CERAMIC	470pF 10% 500VDC	KCK	AMMO PACK RT-HM60 SK YB 471 K	16.095
C73-2	CAPACITOR CERAMIC	470pF 10% 500VDC	KCK	AMMO PACK RT-HM60 SK YB 471 K	16.095
C74-2	CAPACITOR CERAMIC	4n7F 20% CL2 50VDC	NKE	DT 380 758S D 472 M 50V	15.165
C75-2	CAPACITOR CERAMIC	10pF +/-0.5pF N150 50VDC	NKE	FLAT PACK DT 340 758S PH 100 D 50V	15.035
C76-2	CAPACITOR CERAMIC	13pF 5% N150 50VDC	NKE	FLAT PACK DT 340 758S PH 130 J 50V	15.051
C77-2	CAPACITOR CERAMIC	10pF +/-0.5pF N150 50VDC	NKE	FLAT PACK DT 340 758S PH 100 D 50V	15.035
D1-2	DIODE GENERAL PURPOSE	BAV21 200V/0.25A	TFK	BAV21	25.340
D2-2	DIODE GENERAL PURPOSE	BAV21 200V/0.25A	TFK	BAV21	25.340
D3-2	DIODE GENERAL PURPOSE	BAV21 200V/0.25A	TFK	BAV21	25.340
D4-2	DIODE GENERAL PURPOSE	BAV21 200V/0.25A	TFK	BAV21	25.340
D5-2	DIODE ZENER	9V1 5% 5W 1N5346B	MOTOROLA	1N5346B	26.964
D6-2	DIODE SWITCH	BA182	PHILIPS	BA182	25.375
D7-2	DIODE SWITCH	BA182	PHILIPS	BA182	25.375
D8-2	DIODE SWITCH	BA182	PHILIPS	BA182	25.375
D9-2	DIODE SWITCH	BA182	PHILIPS	BA182	25.375
D10-2	DIODE SWITCH	BA182	PHILIPS	BA182	25.375
D11-2	DIODE SWITCH	BA182	PHILIPS	BA182	25.375
D12-2	DIODE SWITCH	BA182	PHILIPS	BA182	25.375
D13-2	DIODE SWITCH	BA182	PHILIPS	BA182	25.375
D14-2	DIODE SWITCH	BA182	PHILIPS	BA182	25.375
D15-2	DIODE SWITCH	BA182	PHILIPS	BA182	25.375
D16-2	DIODE SWITCH	BA182	PHILIPS	BA182	25.375
D17-2	DIODE SWITCH	BA182	PHILIPS	BA182	25.375
FL1-2	CRYSTAL FILTER	Fc=70MHz,BILIT	NDK	70N20B D360B 1SET=2PCS	40.031
FL2-2	CRYSTAL FILTER	Fc=70MHz,BILIT	NDK	70N20B D360B 1SET=2PCS	40.031
FP1-2	FERRITE BEAD	Ø3.7xØ1.2x3.5mm GRADE 4B1	PHILIPS	4322 020 34420	35.181

POSITION	DESCRIPTION		MANUFACTOR	TYPE	S.P. NUMBER
FP2-2	FERRITE BEAD	Ø3.7xØ1.2x3.5mm GRADE 4B1	PHILIPS	4322 020 34420	35.181
FP3-2	FERRITE BEAD	Ø3.7xØ1.2x3.5mm GRADE 4B1	PHILIPS	4322 020 34420	35.181
G1-2	NEON LAMP	90V 5KA/5A	SIEMENS	B1-C90/20L-Q69-X184	45.074
J1-2	RECEPTACLE	BNC RIGHT ANGLE	ROSENBERGER	51K-201-400 A4	78.443
J2-2	SOCKET COAX	PCB MOUNT.	TAIKO	TMP-302X-A1	78.516
J3-2	SOCKET 9 POLES	SUB D RIGHT ANGLE	AMP	343705-2	78.167
J4-2	SOCKET COAX	PCB MOUNT.	TAIKO	TMP-302X-A1	78.516
L1-2	CHOKE FIXED	100uH 5%	SIEMENS	B78108-S1104-J	20.310
L2-2	CHOKE FIXED	100uH 5%	SIEMENS	B78108-S1104-J	20.310
L3-2	CHOKE FIXED	2u2H 10%	FASTRON	MICC-2R2K-02	20.351
L4-2	CHOKE FIXED	2u2H 10%	FASTRON	MICC-2R2K-02	20.351
L5-2	CHOKE FIXED	2u2H 10%	FASTRON	MICC-2R2K-02	20.351
L6-2	CHOKE FIXED	2u2H 10%	FASTRON	MICC-2R2K-02	20.351
L7-2	CHOKE FIXED	2u2H 10%	FASTRON	MICC-2R2K-02	20.351
L8-2	CHOKE FIXED	2u2H 10%	FASTRON	MICC-2R2K-02	20.351
L9-2	CHOKE FIXED	330nH 10%	FASTRON	MICC-R33K-02	20.341
L10-2	CHOKE FIXED	680nH 10%	FASTRON	MICC-R68K-02	20.345
L11-2	CHOKE FIXED	330nH 10%	FASTRON	MICC-R33K-02	20.341
L12-2	CHOKE FIXED	820nH 10%	FASTRON	MICC-8R2K-02	20.346
L13-2	CHOKE FIXED	1u0H 10%	FASTRON	MICC-1R0K-02	20.347
L14-2	CHOKE FIXED	820nH 10%	FASTRON	MICC-R82K-02	20.346
L15-2	CHOKE FIXED	470nH 10%	FASTRON	MICC-R47K-02	20.342
L16-2	CHOKE FIXED	1u5H 10%	FASTRON	MICC-1R5K-02	20.349
L17-2	CHOKE FIXED	2u2H 10%	FASTRON	MICC-2R2K-02	20.351
L18-2	CHOKE FIXED	1u5H 10%	FASTRON	MICC-1R5K-02	20.349
L19-2	CHOKE FIXED	1u0H 10%	FASTRON	MICC-1R0K-02	20.347
L20-2	CHOKE FIXED	4u7H 10%	FASTRON	MICC-4R7K-02	20.355
L21-2	CHOKE FIXED	3u3H 10%	FASTRON	MICC-3R3K-02	20.353
L22-2	CHOKE FIXED	4u7H 10%	FASTRON	MICC-4R7K-02	20.355
L23-2	CHOKE FIXED	1u0H 10%	FASTRON	MICC-1R0K-02	20.347
L24-2	CHOKE FIXED	22uH 5%	FASTRON	SMCC-220J-02	20.302
L25-2	CHOKE FIXED	8u2H 10%	FASTRON	MICC-8R2K-02	20.358
L26-2	CHOKE FIXED	22uH 5%	FASTRON	SMCC-220J-02	20.302
L27-2	CHOKE FIXED	1u0H 10%	FASTRON	MICC-1R0K-02	20.347
L28-2	CHOKE FIXED	4m7H 5%	FASTRON	SMCC-472J-02	20.330
L29-2	CHOKE FIXED	27uH 10%	FASTRON	MICCS-270K-02	20.364
L30-2	CHOKE FIXED	4m7H 5%	FASTRON	SMCC-472J-02	20.330
L31-2	CHOKE FIXED	390nH 10%	FASTRON	MICC-R39K-02	20.340
L32-2	CHOKE FIXED	680nH 10%	FASTRON	MICC-R68K-02	20.345
L33-2	CHOKE FIXED	680nH 10%	FASTRON	MICC-R68K-02	20.345
L34-2	CHOKE FIXED	2u2H 10%	FASTRON	MICC-2R2K-02	20.351
L35-2	COIL RF	586nH ADJUSTABLE	MITSUMI	L-2M7-D3/DM-8100	38.439
L36-2	COIL RF	586nH ADJUSTABLE	MITSUMI	L-2M7-D3/DM-8100	38.439
L37-2	COIL RF	586nH ADJUSTABLE	MITSUMI	L-2M7-D3/DM-8100	38.439

POSITION	DESCRIPTION		MANUFACTOR	TYPE	S.P. NUMBER
L38-2	CHOKE FIXED	2u2H 10%	FASTRON	MICC-2R2K-02	20.351
L39-2	CHOKE FIXED	150nH 10%	FASTRON	MICC-R15K-02	20.337
L40-2	CHOKE FIXED	270nH 10%	FASTRON	MICC-R27K-02	20.339
L41-2	CHOKE FIXED	150nH 10%	FASTRON	MICC-R15K-02	20.337
L42-2	CHOKE FIXED	22uH 5%	FASTRON	SMCC-220J-02	20.302
P1-2	PLUG	2x7 POLES	3M	3598-6002	78.254
Q1-2	TRANSISTOR AF	BC548 NPN T0-92	PHILIPS	BC548 (-A/-B/-C)	28.070
Q2-2	TRANSISTOR AF	BC548 NPN T0-92	PHILIPS	BC548 (-A/-B/-C)	28.070
Q3-2	TRANSISTOR RF	BFW17A PNP T0-39	PHILIPS	BFW17A	29.151
Q4-2	TRANSISTOR FET DUAL	N-CHANNEL J-FET U430	SILICONIX	U430	29.717
R1-2	RESISTOR MF	82 OHM 5% 0.33W	PHILIPS	2322 180 73829	02.446
R2-2	RESISTOR PMF	27 OHM 5% 3W	PHILIPS	2322 195 13279	04.660
R3-2	RESISTOR PMF	27 OHM 5% 3W	PHILIPS	2322 195 13279	04.660
R4-2	RESISTOR MF	27k OHM 5% 0.33W	PHILIPS	2322 180 73273	02.506
R5-2	RESISTOR MF	27k OHM 5% 0.33W	PHILIPS	2322 180 73273	02.506
R6-2	RESISTOR MF	1k2 OHM 5% 0.33W	PHILIPS	2322 180 73122	02.474
R7-2	RESISTOR MF	820 OHM 5% 0.33W	PHILIPS	2322 180 73821	02.470
R8-2	RESISTOR MF	2k7 OHM 5% 0.33W	PHILIPS	2322 180 73272	02.482
R9-2	RESISTOR MF	2k7 OHM 5% 0.33W	PHILIPS	2322 180 73272	02.482
R10-2	RESISTOR MF	2k7 OHM 5% 0.33W	PHILIPS	2322 180 73272	02.482
R11-2	RESISTOR MF	2k7 OHM 5% 0.33W	PHILIPS	2322 180 73272	02.482
R12-2	RESISTOR MF	100 OHM 5% 0.33W	PHILIPS	2322 180 73101	02.448
R13-2	RESISTOR MF	100 OHM 5% 0.33W	PHILIPS	2322 180 73101	02.448
R14-2	RESISTOR MF	100 OHM 5% 0.33W	PHILIPS	2322 180 73101	02.448
R15-2	RESISTOR MF	18k OHM 5% 0.33W	PHILIPS	2322 180 73183	02.502
R16-2	RESISTOR MF	12k OHM 5% 0.33W	PHILIPS	2322 180 73123	02.498
R17-2	RESISTOR MF	27k OHM 5% 0.33W	PHILIPS	2322 180 73273	02.506
R18-2	RESISTOR MF	270k OHM 5% 0.33W	PHILIPS	2322 180 73274	02.530
R19-2	RESISTOR MF	27k OHM 5% 0.33W	PHILIPS	2322 180 73273	02.506
R20-2	RESISTOR MF	270k OHM 5% 0.33W	PHILIPS	2322 180 73274	02.530
R21-2	RESISTOR MF	27k OHM 5% 0.33W	PHILIPS	2322 180 73273	02.506
R22-2	RESISTOR MF	270k OHM 5% 0.33W	PHILIPS	2322 180 73274	02.530
R23-2	RESISTOR MF	27k OHM 5% 0.33W	PHILIPS	2322 180 73273	02.506
R24-2	RESISTOR MF	270k OHM 5% 0.33W	PHILIPS	2322 180 73274	02.530
R25-2	RESISTOR MF	27k OHM 5% 0.33W	PHILIPS	2322 180 73273	02.506
R26-2	RESISTOR MF	270k OHM 5% 0.33W	PHILIPS	2322 180 73274	02.530
R27-2	RESISTOR MF	27k OHM 5% 0.33W	PHILIPS	2322 180 73273	02.506
R28-2	RESISTOR MF	270k OHM 5% 0.33W	PHILIPS	2322 180 73274	02.530
R29-2	RESISTOR MF	820 OHM 5% 0.33W	PHILIPS	2322 180 73821	02.470
R30-2	RESISTOR MF	820 OHM 5% 0.33W	PHILIPS	2322 180 73821	02.470
R31-2	RESISTOR MF	820 OHM 5% 0.33W	PHILIPS	2322 180 73821	02.470
R32-2	RESISTOR MF	820 OHM 5% 0.33W	PHILIPS	2322 180 73821	02.470
R33-2	RESISTOR MF	820 OHM 5% 0.33W	PHILIPS	2322 180 73821	02.470
R34-2	RESISTOR MF	820 OHM 5% 0.33W	PHILIPS	2322 180 73821	02.470

POSITION	DESCRIPTION		MANUFACTOR	TYPE	S.P. NUMBER
R35-2	RESISTOR MF	820 OHM 5% 0.33W	PHILIPS	2322 180 73821	02.470
R36-2	RESISTOR MF	820 OHM 5% 0.33W	PHILIPS	2322 180 73821	02.470
R37-2	RESISTOR MF	820 OHM 5% 0.33W	PHILIPS	2322 180 73821	02.470
R38-2	RESISTOR MF	820 OHM 5% 0.33W	PHILIPS	2322 180 73821	02.470
R39-2	RESISTOR MF	820 OHM 5% 0.33W	PHILIPS	2322 180 73821	02.470
R40-2	RESISTOR MF	820 OHM 5% 0.33W	PHILIPS	2322 180 73821	02.470
R41-2	RESISTOR MF	820 OHM 5% 0.33W	PHILIPS	2322 180 73821	02.470
R42-2	RESISTOR MF	470 OHM 5% 0.33W	PHILIPS	2322 180 73471	02.464
R43-2	RESISTOR MF	220 OHM 5% 0.33W	PHILIPS	2322 180 73221	02.456
R44-2	RESISTOR MF	470 OHM 5% 0.33W	PHILIPS	2322 180 73471	02.464
R45-2	RESISTOR MF	56 OHM 5% 0.33W	PHILIPS	2322 180 73569	02.442
R47-2	RESISTOR MF	120 OHM 5% 0.33W	PHILIPS	2322 180 73121	02.450
R48-2	RESISTOR MF	8k2 OHM 5% 0.33W	PHILIPS	2322 180 73822	02.494
R50-2	RESISTOR MF	33 OHM 5% 0.33W	PHILIPS	2322 180 73339	02.436
R51-2	RESISTOR MF	1k3 OHM 5% 0.33W	PHILIPS	2322 180 73132	02.475
R52-2	RESISTOR MF	220 OHM 5% 0.33W	PHILIPS	2322 180 73221	02.456
R53-2	RESISTOR MF	100 OHM 5% 0.33W	PHILIPS	2322 180 73101	02.448
R54-2	RESISTOR MF	82 OHM 5% 0.33W	PHILIPS	2322 180 73829	02.446
R55-2	RESISTOR MF	56 OHM 5% 0.33W	PHILIPS	2322 180 73569	02.442
RE1-2	RELAY	12VDC 15H. 2A.	MILTRONIC AB	00C-9-1120	21.300
RF2-2	RELAY	15V DC 2A 15H.	SIEMENS	V23040-A0003-B201	21.062
TR1-2	TRANSFORMER	TL495	S.P. RADIO	6-0-25788A R. 890206/LKC	400495
TR2-2	TRANSFORMER	TL519	ESPERA	6-0-25721	400519
TR3-2	TRANSFORMER	TL494	S.P. RADIO	6-0-25813	400494
TR4-2	TRANSFORMER	ADJUSTABLE Fc=70MHz	MITSUMI	L-2M7-D3/DM-7141	38.438
U1-2	INTEGRATED CIRCUIT	8 BIT SHIFT REG. SERIAL IO	NATIONAL	MM74HC595N	34.502
U2-2	QUAD OP. AMP.	324	TEXAS	LM324N	31.065
U3-2	DUAL OP AMP	LM358N	TEXAS	LM358P	31.100

POSITION	DESCRIPTION	MANUFACTOR	TYPE	S.P.NUMBER	
	SYNTHESIZER MODULE 3	RE2100, TCXO: 0.34PPM	ESPERA	625633 w. 0.34PPM TCXO	727070
-1 X01-3	SYNTHESIZER MODULE 3 TCXO C1089A	RE2100 10.73152MHZ 0.34PPM	ESPERA NDK	5-0-25633D C1089A	625633 41.028

POSITION	DESCRIPTION	MANUFACTOR	TYPE	S.P.NUMBER	
	SYNTHESIZER MODULE 3	RE2100	ESPERA	5-0-25633D	625633
C6-3	CAPACITOR CERAMIC	33pF 5% N150 50VDC	NKE	DT 350 758S PH 330 J 50V FLAT PACK	15.092
C7-3	CERAMIC CAPACITOR	22pF 5% N150 50VDC	NKE	DT 340 758S PH 220 J 50V FLAT PACK	15.075
C8-3	CAPACITOR CERAMIC	5p6F +/-0.5pF N150 50VDC	NKE	DT 330 758S PH 5R6 D 50V FLAT PACK	15.013
C9-3	CERAMIC CAPACITOR	22pF 5% N150 50VDC	NKE	DT 340 758S PH 220 J 50V FLAT PACK	15.075
C10-3	CAPACITOR CERAMIC	10nF -20/+80% CL2 50VDC	KCK	RT-HE70 5K YF 103 Z AMMO PACK	15.170
C11-3	CAPACITOR MKT	100nF 5% 63VDC	PHILIPS	2222 370 79104	11.135
C12-3	CAPACITOR CERAMIC	470pF 10% 500VDC	KCK	RT-HM60 5K YB 471 K AMMO PACK	16.095
C13-3	CAPACITOR CERAMIC	10nF -20/+80% CL2 50VDC	KCK	RT-HE70 5K YF 103 Z AMMO PACK	15.170
C14-3	CAPACITOR CERAMIC	470pF 10% 500VDC	KCK	RT-HM60 5K YB 471 K AMMO PACK	16.095
C15-3	CAPACITOR MKT	1uF 10% 63VDC	PHILIPS	2222 370 78105	11.137
C16-3	CAPACITOR MKT	330nF 10% 63VDC	PHILIPS	2222 370 78334	11.189
C17-3	CAPACITOR MKT	330nF 10% 63VDC	PHILIPS	2222 370 78334	11.189
C18-3	CAPACITOR CERAMIC	39pF 5% N150 50VDC	NKE	DT 360 758L PH 390 J 50V FLAT PACK	15.090
C19-3	CERAMIC CAPACITOR	22pF 5% N150 50VDC	NKE	DT 340 758S PH 220 J 50V FLAT PACK	15.075
C20-3	CAPACITOR MKT	220nF 10% 63VDC	PHILIPS	2222 370 78224	11.095
C21-3	CAPACITOR MKT	220nF 10% 63VDC	PHILIPS	2222 370 78224	11.095
C22-3	CAPACITOR CERAMIC	5p6F +/-0.5pF N150 50VDC	NKE	DT 330 758S PH 5R6 D 50V FLAT PACK	15.013
C23-3	CERAMIC CAPACITOR	22pF 5% N150 50VDC	NKE	DT 340 758S PH 220 J 50V FLAT PACK	15.075
C24-3	CAPACITOR CERAMIC	10nF -20/+80% CL2 50VDC	KCK	RT-HE70 5K YF 103 Z AMMO PACK	15.170
C25-3	CAPACITOR CERAMIC	470pF 10% 500VDC	KCK	RT-HM60 5K YB 471 K AMMO PACK	16.095
C26-3	CAPACITOR MKT	1uF 10% 63VDC	PHILIPS	2222 370 78105	11.137
C27-3	CAPACITOR CERAMIC	10nF -20/+80% CL2 50VDC	KCK	RT-HE70 5K YF 103 Z AMMO PACK	15.170
C28-3	CAPACITOR CERAMIC	470pF 10% 500VDC	KCK	RT-HM60 5K YB 471 K AMMO PACK	16.095
C29-3	CAPACITOR MKT	330nF 10% 63VDC	PHILIPS	2222 370 78334	11.189
C30-3	CAPACITOR MKT	330nF 10% 63VDC	PHILIPS	2222 370 78334	11.189

POSITION	DESCRIPTION	MANUFACTOR	TYPE	S.P.NUMBER	
C31-3	CAPACITOR MKT	1uF 10% 63VDC	PHILIPS	2222 370 78105	11.137
C32-3	CAPACITOR CERAMIC	39pF 5% N150 50VDC	NKE	DT 360 758L PH 390 J 50V FLAT PACK	15.090
C33-3	CAPACITOR MKT	220nF 10% 63VDC	PHILIPS	2222 370 78224	11.095
C34-3	CAPACITOR MKT	220nF 10% 63VDC	PHILIPS	2222 370 78224	11.095
C35-3	CAPACITOR CERAMIC	15pF 5% N150 50VDC	KCK	RT-HE40-5K PH 150 J AMMO PACK	15.055
C36-3	CAPACITOR CERAMIC	5p6F +/-0.5pF N150 50VDC	NKE	DT 330 758S PH 5R6 D 50V FLAT PACK	15.013
C37-3	CAPACITOR CERAMIC	33pF 5% N150 50VDC	NKE	DT 350 758S PH 330 J 50V FLAT PACK	15.092
C38-3	CAPACITOR CERAMIC	10nF -20/+80% CL2 50VDC	KCK	RT-HE70 5K YF 103 Z AMMO PACK	15.170
C39-3	CAPACITOR CERAMIC	470pF 10% 500VDC	KCK	RT-HM60 5K YB 471 K AMMO PACK	16.095
C40-3	CAPACITOR MKT	1uF 10% 63VDC	PHILIPS	2222 370 78105	11.137
C41-3	CAPACITOR CERAMIC	10nF -20/+80% CL2 50VDC	KCK	RT-HE70 5K YF 103 Z AMMO PACK	15.170
C42-3	CAPACITOR CERAMIC	470pF 10% 500VDC	KCK	RT-HM60 5K YB 471 K AMMO PACK	16.095
C43-3	CAPACITOR MKT	220nF 10% 63VDC	PHILIPS	2222 370 78224	11.095
C44-3	CAPACITOR MKT	220nF 10% 63VDC	PHILIPS	2222 370 78224	11.095
C45-3	CAPACITOR MKT	220nF 10% 63VDC	PHILIPS	2222 370 78224	11.095
C46-3	CAPACITOR MKT	220nF 10% 63VDC	PHILIPS	2222 370 78224	11.095
C47-3	CAPACITOR MKT	220nF 10% 63VDC	PHILIPS	2222 370 78224	11.095
C48-3	CAPACITOR MKT	220nF 10% 63VDC	PHILIPS	2222 370 78224	11.095
C49-3	CAPACITOR CERAMIC	470pF 10% 500VDC	KCK	RT-HM60 5K YB 471 K AMMO PACK	16.095
C50-3	CAPACITOR MKT	220nF 10% 63VDC	PHILIPS	2222 370 78224	11.095
C51-3	CAPACITOR MKT	47nF 5% 63VDC	PHILIPS	2222 370 79473	11.156
C52-3	CAPACITOR CERAMIC	43pF 5% N150 50VDC	NKE	DT 360 758S PH 430 J 50V FLAT PACK	15.097
C53-3	CAPACITOR MKT	220nF 10% 63VDC	PHILIPS	2222 370 78224	11.095
C54-3	CAPACITOR MKT	47nF 5% 63VDC	PHILIPS	2222 370 79473	11.156
C55-3	CAPACITOR CERAMIC	15pF 5% N150 50VDC	KCK	RT-HE40-5K PH 150 J AMMO PACK	15.055
C56-3	CAPACITOR CERAMIC	5p6F +/-0.5pF N150 50VDC	NKE	DT 330 758S PH 5R6 D 50V FLAT PACK	15.013
C57-3	CAPACITOR CERAMIC	33pF 5% N150 50VDC	NKE	DT 350 758S PH 330 J 50V FLAT PACK	15.092
C58-3	CAPACITOR MKT	220nF 10% 63VDC	PHILIPS	2222 370 78224	11.095
C59-3	CAPACITOR MKT	220nF 10% 63VDC	PHILIPS	2222 370 78224	11.095
C60-3	CAPACITOR ELECTROLYTIC	10uF 20% 35VDC	ERO	EKI 00 AA 210 F M9	14.512
C61-3	CAPACITOR CERAMIC	10nF -20/+80% CL2 50VDC	KCK	RT-HE70 5K YF 103 Z	15.170

RE2100 35/91

POSITION	DESCRIPTION		MANUFACTOR	TYPE	S.P.NUMBER
C62-3	CAPACITOR MKT	220nF 10% 63VDC	PHILIPS	AMMO PACK 2222 370 78224	11.095
C63-3	CAPACITOR MKT	220nF 10% 63VDC	PHILIPS	2222 370 78224	11.095
C64-3	CAPACITOR MKT	220nF 10% 63VDC	PHILIPS	2222 370 78224	11.095
C65-3	CAPACITOR CERAMIC	470pF 10% 500VDC	KCK	RT-HM60 SK YB 471 K AMMO PACK	16.095
C66-3	CAPACITOR MKT	100nF 5% 63VDC	PHILIPS	2222 370 79104	11.135
C67-3	CAPACITOR MKT	220nF 10% 63VDC	PHILIPS	2222 370 78224	11.095
C68-3	CAPACITOR MKT	220nF 10% 63VDC	PHILIPS	2222 370 78224	11.095
C69-3	CAPACITOR CERAMIC	470pF 10% 500VDC	KCK	RT-HM60 SK YB 471 K AMMO PACK	16.095
C70-3	CAPACITOR CERAMIC	10nF -20/+80% CL2 50VDC	KCK	RT-HE70 SK YF 103 Z AMMO PACK	15.170
C71-3	CAPACITOR MKT	220nF 10% 63VDC	PHILIPS	2222 370 78224	11.095
C73-3	CAPACITOR MKT	220nF 10% 63VDC	PHILIPS	2222 370 78224	11.095
C75-3	CAPACITOR MKT	220nF 10% 63VDC	PHILIPS	2222 370 78224	11.095
C76-3	CAPACITOR MKT	220nF 10% 63VDC	PHILIPS	2222 370 78224	11.095
C77-3	CAPACITOR CERAMIC	10nF -20/+80% CL2 50VDC	KCK	RT-HE70 SK YF 103 Z AMMO PACK	15.170
C78-3	CAPACITOR CERAMIC	470pF 10% 500VDC	KCK	RT-HM60 SK YB 471 K AMMO PACK	16.095
C79-3	CAPACITOR MKT	1uF 10% 63VDC	PHILIPS	2222 370 78105	11.137
C80-3	CAPACITOR MKT	220nF 10% 63VDC	PHILIPS	2222 370 78224	11.095
C81-3	CAPACITOR CERAMIC	470pF 10% 500VDC	KCK	RT-HM60 SK YB 471 K AMMO PACK	16.095
C82-3	CAPACITOR MKT	220nF 10% 63VDC	PHILIPS	2222 370 78224	11.095
C83-3	CAPACITOR CERAMIC	470pF 10% 500VDC	KCK	RT-HM60 SK YB 471 K AMMO PACK	16.095
C84-3	CAPACITOR ELECTROLYTIC	100uF -10/+50% 25VDC	ERO	EKM 00 CC 310 E 65	14.610
C85-3	CAPACITOR ELECTROLYTIC	10uF 20% 35VDC	ERO	EKI 00 AA 210 F M9	14.512
C86-3	CAPACITOR CERAMIC	10nF -20/+80% CL2 50VDC	KCK	RT-HE70 SK YF 103 Z AMMO PACK	15.170
C87-3	CAPACITOR MKT	220nF 10% 63VDC	PHILIPS	2222 370 78224	11.095
C88-3	CAPACITOR CERAMIC	10nF -20/+80% CL2 50VDC	KCK	RT-HE70 SK YF 103 Z AMMO PACK	15.170
C91-3	CAPACITOR CERAMIC	470pF 10% 500VDC	KCK	RT-HM60 SK YB 471 K AMMO PACK	16.095
C92-3	CAPACITOR CERAMIC	470pF 10% 500VDC	KCK	RT-HM60 SK YB 471 K AMMO PACK	16.095
C93-3	CAPACITOR CERAMIC	470pF 10% 500VDC	KCK	RT-HM60 SK YB 471 K AMMO PACK	16.095
C94-3	CAPACITOR CERAMIC	1p8F +/-0.25pF NPO 100VDC	PHILIPS	2222 683 09188	15.008
C95-3	CAPACITOR MULTILAYER	3n3F 2% NPO 50DC	VITRAMON	VP32 BA3326A-T-AMMO PACK	16.295
C96-3	CAPACITOR ELECTROLYTIC	47uF 20% 25VDC	ERO	EKI 00 BB 247 E M9	14.524

POSITION	DESCRIPTION		MANUFACTOR	TYPE	S.P.NUMBER
C97-3	CAPACITOR CERAMIC	10nF -20/+80% CL2 50VDC	KCK	RT-HE70 SK YF 103 Z AMMO PACK	15.170
C98-3	CAPACITOR CERAMIC	470pF 10% 500VDC	KCK	RT-HM60 SK YB 471 K AMMO PACK	16.095
C99-3	CAPACITOR CERAMIC	4p7F +/-0.25pF N150 50VDC	KCK	RT-HE40 SK PH 4R7 C AMMO PACK	15.005
C100-3	CAPACITOR CERAMIC	470pF 10% 500VDC	KCK	RT-HM60 SK YB 471 K AMMO PACK	16.095
C101-3	CAPACITOR MKT	220nF 10% 63VDC	PHILIPS	2222 370 78224	11.095
C102-3	CAPACITOR CERAMIC	470pF 10% 500VDC	KCK	RT-HM60 SK YB 471 K AMMO PACK	16.095
C103-3	CAPACITOR CERAMIC	470pF 10% 500VDC	KCK	RT-HM60 SK YB 471 K AMMO PACK	16.095
C104-3	CAPACITOR CERAMIC	470pF 10% 500VDC	KCK	RT-HM60 SK YB 471 K AMMO PACK	16.095
C105-3	CAPACITOR CERAMIC	470pF 10% 500VDC	KCK	RT-HM60 SK YB 471 K AMMO PACK	16.095
C106-3	CAPACITOR CERAMIC	10nF -20/+80% CL2 50VDC	KCK	RT-HE70 SK YF 103 Z AMMO PACK	15.170
C107-3	CAPACITOR CERAMIC	470pF 10% 500VDC	KCK	RT-HM60 SK YB 471 K AMMO PACK	16.095
C108-3	CAPACITOR CERAMIC	470pF 10% 500VDC	KCK	RT-HM60 SK YB 471 K AMMO PACK	16.095
C109-3	CAPACITOR CERAMIC	10nF -20/+80% CL2 50VDC	KCK	RT-HE70 SK YF 103 Z AMMO PACK	15.170
C110-3	CAPACITOR MKT	220nF 10% 63VDC	PHILIPS	2222 370 78224	11.095
C112-3	CAPACITOR MULTILAYER	3n3F 2% NPO 50DC	VITRAMON	VP32 BA3326A-T-AMMO PACK	16.295
C113-3	CAPACITOR ELECTROLYTIC	47uF 20% 25VDC	ERO	EKI 00 BB 247 E M9	14.524
C115-3	CAPACITOR CERAMIC	470pF 10% 500VDC	KCK	RT-HM60 SK YB 471 K AMMO PACK	16.095
C117-3	CAPACITOR CERAMIC	470pF 10% 500VDC	KCK	RT-HM60 SK YB 471 K AMMO PACK	16.095
C118-3	CAPACITOR CERAMIC	470pF 10% 500VDC	KCK	RT-HM60 SK YB 471 K AMMO PACK	16.095
C119-3	CAPACITOR CERAMIC	10nF -20/+80% CL2 50VDC	KCK	RT-HE70 SK YF 103 Z AMMO PACK	15.170
C123-3	CAPACITOR CERAMIC	10nF -20/+80% CL2 50VDC	KCK	RT-HE70 SK YF 103 Z AMMO PACK	15.170
C124-3	CAPACITOR CERAMIC	10nF -20/+80% CL2 50VDC	KCK	RT-HE70 SK YF 103 Z AMMO PACK	15.170
C125-3	CAPACITOR CERAMIC	10nF -20/+80% CL2 50VDC	KCK	RT-HE70 SK YF 103 Z AMMO PACK	15.170
C126-3	CAPACITOR MKT	220nF 10% 63VDC	PHILIPS	2222 370 78224	11.095
C127-3	CAPACITOR MKT	220nF 10% 63VDC	PHILIPS	2222 370 78224	11.095



POSITION	DESCRIPTION		MANUFACTOR	TYPE	S.P. NUMBER
C128-3	CAPACITOR ELECTROLYTIC	4.7uF 20% 50VDC	ERO	EKI 00 AA 147 H M9	14.510
C129-3	CERAMIC CAPACITOR	22pF 5% N150 50VDC	NKE	DT 340 758S PH 220 J 50V FLAT PACK	15.075
C130-3	CAPACITOR CERAMIC	36pF 5% N150 50VDC	NKE	DT 350 758S PH 360 J 50V FLAT PACK	15.088
C131-3	CAPACITOR MKT	39nF 5% 63VDC	PHILIPS	2222 370 79393	11.155
C132-3	CAPACITOR CERAMIC	470pF 10% 500VDC	KCK	RT-HM60 SK YB 471 K AMMO PACK	16.095
C135-3	CAPACITOR CERAMIC	10nF -20/+80% CL2 50VDC	KCK	RT-HE70 SK YF 103 Z AMMO PACK	15.170
C136-3	CAPACITOR ELECTROLYTIC	47uF 20% 25VDC	ERO	EKI 00 08 247 E M9	14.524
C137-3	CAPACITOR CERAMIC	2p7F +/-0.25pF N150 50VDC	NKE	DT 330 758S PJ 2R7 C 50V FLAT PACK	15.001
C138-3	CAPACITOR MKT	22nF 5% 100VDC	PHILIPS	2222 370 89223	11.169
C139-3	CAPACITOR CERAMIC	13pF 5% N150 50VDC	NKE	DT 340 758S PH 130 J 50V FLAT PACK	15.051
C140-3	CAPACITOR CERAMIC	470pF 10% 500VDC	KCK	RT-HM60 SK YB 471 K AMMO PACK	16.095
C141-3	CAPACITOR MKT	68nF 5% 63VDC	PHILIPS	2222 370 79683	11.178
C142-3	CAPACITOR CERAMIC	470pF 10% 500VDC	KCK	RT-HM60 SK YB 471 K AMMO PACK	16.095
C143-3	CAPACITOR MKT	39nF 5% 63VDC	PHILIPS	2222 370 79393	11.155
C144-3	CAPACITOR CERAMIC	10nF -20/+80% CL2 50VDC	KCK	RT-HE70 SK YF 103 Z AMMO PACK	15.170
C145-3	CAPACITOR CERAMIC	470pF 10% 500VDC	KCK	RT-HM60 SK YB 471 K AMMO PACK	16.095
C146-3	CAPACITOR MKT	220nF 10% 63VDC	PHILIPS	2222 370 78224	11.095
C147-3	CAPACITOR MKT	22nF 5% 100VDC	PHILIPS	2222 370 89223	11.169
C148-3	CAPACITOR CERAMIC	470pF 10% 500VDC	KCK	RT-HM60 SK YB 471 K AMMO PACK	16.095
C149-3	CAPACITOR CERAMIC	36pF 5% N150 50VDC	NKE	DT 350 758S PH 360 J 50V FLAT PACK	15.088
C150-3	CAPACITOR CERAMIC	43pF 5% N150 50VDC	NKE	DT 360 758S PH 430 J 50V FLAT PACK	15.097
C151-3	CAPACITOR CERAMIC	10nF -20/+80% CL2 50VDC	KCK	RT-HE70 SK YF 103 Z AMMO PACK	15.170
C152-3	CAPACITOR ELECTROLYTIC	4.7uF 20% 50VDC	ERO	EKI 00 AA 147 H M9	14.510
C153-3	CAPACITOR CERAMIC	470pF 10% 500VDC	KCK	RT-HM60 SK YB 471 K AMMO PACK	16.095
C154-3	CAPACITOR MKT	220nF 10% 63VDC	PHILIPS	2222 370 78224	11.095
C155-3	CAPACITOR CERAMIC	2p7F +/-0.25pF N150 50VDC	NKE	DT 330 758S PJ 2R7 C 50V FLAT PACK	15.001
C156-3	CAPACITOR CERAMIC	20pF 5% N150 50VDC	KCK	RT HE40 SM PH 200 J AMMO PACK	15.065

POSITION	DESCRIPTION		MANUFACTOR	TYPE	S.P. NUMBER
C157-3	CAPACITOR CERAMIC	10nF -20/+80% CL2 50VDC	KCK	RT-HE70 SK YF 103 Z AMMO PACK	15.170
C158-3	CAPACITOR CERAMIC	470pF 10% 500VDC	KCK	RT-HM60 SK YB 471 K AMMO PACK	16.095
C160-3	CAPACITOR CERAMIC	470pF 10% 500VDC	KCK	RT-HM60 SK YB 471 K AMMO PACK	16.095
C170-3	CAPACITOR CERAMIC	470pF 10% 500VDC	KCK	RT-HM60 SK YB 471 K AMMO PACK	16.095
C173-3	CAPACITOR CERAMIC	470pF 10% 500VDC	KCK	RT-HM60 SK YB 471 K AMMO PACK	16.095
C174-3	CAPACITOR CERAMIC	470pF 10% 500VDC	KCK	RT-HM60 SK YB 471 K AMMO PACK	16.095
C175-3	CAPACITOR CERAMIC	470pF 10% 500VDC	KCK	RT-HM60 SK YB 471 K AMMO PACK	16.095
C176-3	CAPACITOR CERAMIC	10pF +/-0.5pF N150 50VDC	NKE	DT 340 758S PH 100 D 50V FLAT PACK	15.035
C177-3	CAPACITOR CERAMIC	6p8F +/-0.5pF N150 50VDC	NKE	DT 330 758S PH 6R8 D 50V FLAT PACK	15.020
C178-3	CAPACITOR MKT	220nF 10% 63VDC	PHILIPS	2222 370 78224	11.095
C179-3	CAPACITOR CERAMIC	470pF 10% 500VDC	KCK	RT-HM60 SK YB 471 K AMMO PACK	16.095
C180-3	CAPACITOR CERAMIC	470pF 10% 500VDC	KCK	RT-HM60 SK YB 471 K AMMO PACK	16.095
C181-3	CAPACITOR CERAMIC	470pF 10% 500VDC	KCK	RT-HM60 SK YB 471 K AMMO PACK	16.095
C182-3	CAPACITOR CERAMIC	1n0F 10% CL2 500VDC	KCK	RT-HM60 SK YB 102 K AMMO PACK	15.160
C183-3	CAPACITOR CERAMIC	470pF 10% 500VDC	KCK	RT-HM60 SK YB 471 K AMMO PACK	16.095
C184-3	CAPACITOR CERAMIC	10nF -20/+80% CL2 50VDC	KCK	RT-HE70 SK YF 103 Z AMMO PACK	15.170
C185-3	CAPACITOR CERAMIC	470pF 10% 500VDC	KCK	RT-HM60 SK YB 471 K AMMO PACK	16.095
C186-3	CAPACITOR CERAMIC	470pF 10% 500VDC	KCK	RT-HM60 SK YB 471 K AMMO PACK	16.095
C187-3	CAPACITOR CERAMIC	470pF 10% 500VDC	KCK	RT-HM60 SK YB 471 K AMMO PACK	16.095
C188-3	CAPACITOR CERAMIC	10nF -20/+80% CL2 50VDC	KCK	RT-HE70 SK YF 103 Z AMMO PACK	15.170
C189-3	CAPACITOR CERAMIC	10nF -20/+80% CL2 50VDC	KCK	RT-HE70 SK YF 103 Z AMMO PACK	15.170
C190-3	CAPACITOR CERAMIC	470pF 10% 500VDC	KCK	RT-HM60 SK YB 471 K AMMO PACK	16.095
C191-3	CAPACITOR CERAMIC	470pF 10% 500VDC	KCK	RT-HM60 SK YB 471 K	16.095

POSITION	DESCRIPTION		MANUFACTURER	TYPE	S.P. NUMBER
C192-3	CAPACITOR CERAMIC	470pF 10% 500VDC	KCK	AMMO PACK RT-HM60 SK YB 471 K	16.095
C193-3	CAPACITOR MKT	0.1uF 10% 63VDC	PHILIPS	AMMO PACK 2222 370 78104	11.136
C194-3	CAPACITOR CERAMIC	470pF 10% 500VDC	KCK	RT-HM60 SK YB 471 K AMMO PACK	16.095
C195-3	CAPACITOR CERAMIC	470pF 10% 500VDC	KCK	RT-HM60 SK YB 471 K AMMO PACK	16.095
C196-3	CAPACITOR CERAMIC	470pF 10% 500VDC	KCK	RT-HM60 SK YB 471 K AMMO PACK	16.095
C197-3	CAPACITOR CERAMIC	10nF -20/+80% CL2 50VDC	KCK	RT-HE70 SK YF 103 Z AMMO PACK	15.170
C198-3	CAPACITOR ELECTROLYTIC	47uF 20% 25VDC	ERO	EKI 00 BB 247 E M9	14.524
C199-3	CAPACITOR CERAMIC	10nF -20/+80% CL2 50VDC	KCK	RT-HE70 SK YF 103 Z AMMO PACK	15.170
C200-3	CAPACITOR CERAMIC	10nF -20/+80% CL2 50VDC	KCK	RT-HE70 SK YF 103 Z AMMO PACK	15.170
C201-3	CAPACITOR MKT	1uF 10% 63VDC	PHILIPS	2222 370 78105	11.137
C202-3	CAPACITOR CERAMIC	10nF -20/+80% CL2 50VDC	KCK	RT-HE70 SK YF 103 Z AMMO PACK	15.170
C203-3	CAPACITOR CERAMIC	10nF -20/+80% CL2 50VDC	KCK	RT-HE70 SK YF 103 Z AMMO PACK	15.170
C204-3	CAPACITOR CERAMIC	10nF -20/+80% CL2 50VDC	KCK	RT-HE70 SK YF 103 Z AMMO PACK	15.170
C205-3	CAPACITOR MKT	220nF 10% 63VDC	PHILIPS	2222 370 78224	11.095
C206-3	CAPACITOR MKT	220nF 10% 63VDC	PHILIPS	2222 370 78224	11.095
C207-3	CAPACITOR CERAMIC	10nF -20/+80% CL2 50VDC	KCK	RT-HE70 SK YF 103 Z AMMO PACK	15.170
C208-3	CAPACITOR ELECTROLYTIC	4.7uF 20% 50VDC	ERO	EKI 00 AA 147 H M9	14.510
C209-3	CAPACITOR ELECTROLYTIC	4.7uF 20% 50VDC	ERO	EKI 00 AA 147 H M9	14.510
C210-3	CAPACITOR ELECTROLYTIC	4.7uF 20% 50VDC	ERO	EKI 00 AA 147 H M9	14.510
C211-3	CAPACITOR ELECTROLYTIC	4.7uF 20% 50VDC	ERO	EKI 00 AA 147 H M9	14.510
C212-3	CAPACITOR ELECTROLYTIC	47uF 20% 25VDC	ERO	EKI 00 BB 247 E M9	14.524
C213-3	CAPACITOR CERAMIC	470pF 10% 500VDC	KCK	RT-HM60 SK YB 471 K AMMO PACK	16.095
C214-3	CAPACITOR CERAMIC	470pF 10% 500VDC	KCK	RT-HM60 SK YB 471 K AMMO PACK	16.095
C216-3	CAPACITOR CERAMIC	330pF 20% 500VDC	FERROPERM	330pF +-20% 9/0129.9-400V	16.093
D1-3	DIODE CAPACITANCE	4.5pF/28VDC	PHILIPS	BB809	26.125
D2-3	DIODE SWITCH	BA243	TFK	BA243	25.386
D3-3	DIODE CAPACITANCE	4.5pF/28VDC	PHILIPS	BB809	26.125
D4-3	DIODE CAPACITANCE	4.5pF/28VDC	PHILIPS	BB809	26.125
D5-3	DIODE SWITCH	BA243	TFK	BA243	25.386
D6-3	DIODE CAPACITANCE	4.5pF/28VDC	PHILIPS	BB809	26.125

POSITION	DESCRIPTION		MANUFACTURER	TYPE	S.P. NUMBER
D7-3	DIODE SWITCH	BA243	TFK	BA243	25.386
D8-3	DIODE CAPACITANCE	4.5pF/28VDC	PHILIPS	BB809	26.125
D9-3	DIODE CAPACITANCE	4.5pF/28VDC	PHILIPS	BB809	26.125
D10-3	DIODE SWITCH	BA243	TFK	BA243	25.386
D11-3	DIODE HIGH SPEED	1N4448	PHILIPS	1N4448	25.147
D12-3	DIODE HIGH SPEED	1N4448	PHILIPS	1N4448	25.147
D13-3	DIODE ZENER	2V4 5% 0.4W	PHILIPS	BZX79C2V7	26.506
D14-3	DIODE HIGH SPEED	1N4448	PHILIPS	1N4448	25.147
D15-3	DIODE HIGH SPEED	1N4448	PHILIPS	1N4448	25.147
D16-3	DIODE HIGH SPEED	1N4448	PHILIPS	1N4448	25.147
D17-3	DIODE ZENER	2V4 5% 0.4W	PHILIPS	BZX79C2V4	26.505
D18-3	DIODE SWITCH	BA243	TFK	BA243	25.386
D19-3	DIODE CAPACITANCE	4.5pF/28VDC	PHILIPS	BB809	26.125
D20-3	DIODE SCHOTTKY BARRIER	70V/15mA D0-35	SGS-THOMSON	1N5711	27.500
D21-3	DIODE SWITCH	BA243	TFK	BA243	25.386
D22-3	DIODE CAPACITANCE	4.5pF/28VDC	PHILIPS	BB809	26.125
D23-3	DIODE SCHOTTKY BARRIER	70V/15mA D0-35	SGS-THOMSON	1N5711	27.500
D24-3	DIODE SWITCH	BA243	TFK	BA243	25.386
D25-3	DIODE HIGH SPEED	1N4448	PHILIPS	1N4448	25.147
D26-3	DIODE SWITCH	BA243	TFK	BA243	25.386
J1-3	SOCKET COAX	VERTICAL FOR PCB MOUNT.	TAIKO	TMP-J01X-V6	78.518
J2-3	SOCKET COAX	VERTICAL FOR PCB MOUNT.	TAIKO	TMP-J01X-V6	78.518
J3-3	SOCKET COAX	VERTICAL FOR PCB MOUNT.	TAIKO	TMP-J01X-V6	78.518
J4-3	SOCKET COAX	VERTICAL FOR PCB MOUNT.	TAIKO	TMP-J01X-V6	78.518
J5-3	SOCKET COAX	VERTICAL FOR PCB MOUNT.	TAIKO	TMP-J01X-V6	78.518
J6-3	SOCKET COAX	VERTICAL FOR PCB MOUNT.	TAIKO	TMP-J01X-V6	78.518
L1-3	CHOKE FIXED	3u9H 10%	FASTRON	MICC-3R9K-02	20.354
L3-3	CHOKE FIXED	3u9H 10%	FASTRON	MICC-3R9K-02	20.354
L4-3	CHOKE FIXED	470uH 5%	FASTRON	SMCC-471J-02	20.318
L5-3	CHOKE FIXED	3u9H 10%	FASTRON	MICC-3R9K-02	20.354
L6-3	CHOKE FIXED	3u9H 10%	FASTRON	MICC-3R9K-02	20.354
L8-3	CHOKE FIXED	470uH 5%	FASTRON	SMCC-471J-02	20.318
L9-3	CHOKE FIXED	3u9H 10%	FASTRON	MICC-3R9K-02	20.354
L10-3	CHOKE FIXED	3u9H 10%	FASTRON	MICC-3R9K-02	20.354
L11-3	CHOKE FIXED	470uH 5%	FASTRON	SMCC-471J-02	20.318
L12-3	CHOKE FIXED	3u9H 10%	FASTRON	MICC-3R9K-02	20.354
L13-3	CHOKE FIXED	3u9H 10%	FASTRON	MICC-3R9K-02	20.354
L14-3	CHOKE FIXED	3u9H 10%	FASTRON	MICC-3R9K-02	20.354
L16-3	CHOKE FIXED	470uH 5%	FASTRON	SMCC-471J-02	20.318
L17-3	CHOKE FIXED	100uH 10%	FASTRON	MICCS-101K-02	20.371
L18-3	CHOKE FIXED	100uH 10%	FASTRON	MICCS-101K-02	20.371
L19-3	CHOKE FIXED	100uH 10%	FASTRON	MICCS-101K-02	20.371
L20-3	CHOKE FIXED	100uH 10%	FASTRON	MICCS-101K-02	20.371
L21-3	CHOKE FIXED	3u9H 10%	FASTRON	MICC-3R9K-02	20.354

POSITION	DESCRIPTION		MANUFACTOR	TYPE	S.P. NUMBER
L22-3	CHOKE FIXED	4m7H 5%	FASTRON	SMCC-472J-02	20.330
L24-3	CHOKE FIXED	100uH 10%	FASTRON	MICCS-101K-02	20.371
L25-3	CHOKE FIXED	100uH 10%	FASTRON	MICCS-101K-02	20.371
L26-3	CHOKE FIXED	100uH 10%	FASTRON	MICCS-101K-02	20.371
L27-3	CHOKE FIXED	270nH 10%	FASTRON	MJCC-R27K-02	20.339
L28-3	CHOKE FIXED	3u9H 10%	FASTRON	MICC-3R9K-02	20.354
L29-3	CHOKE FIXED	3u9H 10%	FASTRON	MICC-3R9K-02	20.354
L30-3	CHOKE FIXED	10uH 10%	FASTRON	MICC-100K-02	20.359
L32-3	CHOKE FIXED	3u9H 10%	FASTRON	MICC-3R9K-02	20.354
L33-3	CHOKE FIXED	1u5H 10%	FASTRON	MICC-1R5K-02	20.349
L34-3	CHOKE FIXED	4m7H 5%	FASTRON	SMCC-472J-02	20.330
L35-3	CHOKE FIXED	4m7H 5%	FASTRON	SMCC-472J-02	20.330
L36-3	CHOKE FIXED	10uH 10%	FASTRON	MJCC-100K-02	20.359
L38-3	CHOKE FIXED	3u9H 10%	FASTRON	MICC-3R9K-02	20.354
L39-3	CHOKE FIXED	2u2H 10%	FASTRON	MICC-2R2K-02	20.351
L40-3	CHOKE FIXED	0.56uH 10%	FASTRON	MICC-R56K-02	20.344
L41-3	CHOKE FIXED	3u9H 10%	FASTRON	MICC-3R9K-02	20.354
L42-3	CHOKE FIXED	3u9H 10%	FASTRON	MICC-3R9K-02	20.354
L43-3	CHOKE FIXED	3u9H 10%	FASTRON	MICC-3R9K-02	20.354
L44-3	CHOKE FIXED	3u9H 10%	FASTRON	MICC-3R9K-02	20.354
L45-3	CHOKE FIXED	3u9H 10%	FASTRON	MICC-3R9K-02	20.354
L46-3	CHOKE FIXED	470uH 5%	FASTRON	SMCC-471J-02	20.318
L47-3	CHOKE FIXED	3u9H 10%	FASTRON	MICC-3R9K-02	20.354
L48-3	CHOKE FIXED	3u9H 10%	FASTRON	MICC-3R9K-02	20.354
L49-3	CHOKE FIXED	3u9H 10%	FASTRON	MICC-3R9K-02	20.354
L50-3	CHOKE FIXED	100uH 10%	FASTRON	MICCS-101K-02	20.371
P1-3	PLUG	2x7 POLES	3M	3598-6002	78.254
Q1-3	TRANSISTOR AF	BC548 NPN T0-92	PHILIPS	BC548 (-A/-B/-C)	28.070
Q2-3	TRANSISTOR JFET	T1S88A3 T0-92	MOTOROLA	TM 00 044-3	29.737
Q3-3	TRANSISTOR AF	BC558 PNP T0-92	PHILIPS	BC558 (-A/-B/-C)	28.095
Q4-3	TRANSISTOR AF	BC548 NPN T0-92	PHILIPS	BC548 (-A/-B/-C)	28.070
Q5-3	TRANSISTOR JFET	T1S88A3 T0-92	MOTOROLA	TM 00 044-3	29.737
Q6-3	TRANSISTOR AF	BC558 PNP T0-92	PHILIPS	BC558 (-A/-B/-C)	28.095
Q7-3	TRANSISTOR AF	BC548 NPN T0-92	PHILIPS	BC548 (-A/-B/-C)	28.070
Q8-3	TRANSISTOR JFET	T1S88A3 T0-92	MOTOROLA	TM 00 044-3	29.737
Q9-3	TRANSISTOR AF	BC558 PNP T0-92	PHILIPS	BC558 (-A/-B/-C)	28.095
Q10-3	TRANSISTOR AF	BC548 NPN T0-92	PHILIPS	BC548 (-A/-B/-C)	28.070
Q11-3	TRANSISTOR JFET	T1S88A3 T0-92	MOTOROLA	TM 00 044-3	29.737
Q12-3	TRANSISTOR AF	BC558 PNP T0-92	PHILIPS	BC558 (-A/-B/-C)	28.095
Q13-3	TRANSISTOR RF	BFW92A	TEK	BFW92A	29.160
Q14-3	TRANSISTOR N-CHAN. JFET	T1S88A1	MOTOROLA	TM 00 044 -1	29.735
Q15-3	TRANSISTOR RF SWITCH	2N2369A	MOTOROLA	2N2369A	28.315
Q16-3	TRANSISTOR RF SWITCH	MPS3640	MOTOROLA	MPS-3640	28.405
Q17-3	TRANSISTOR RF	BF199	PHILIPS	BF199	28.178

POSITION	DESCRIPTION		MANUFACTOR	TYPE	S.P. NUMBER
Q18-3	TRANSISTOR RF	BF199	PHILIPS	BF199	28.178
Q19-3	TRANSISTOR MOSFET	N-CHANNEL ENHANCEMENT	SILICONIX	SD210DE	29.719
Q20-3	TRANSISTOR RF SWITCH	2N2369A	MOTOROLA	2N2369A	28.315
Q21-3	TRANSISTOR RF	BF199	PHILIPS	BF199	28.178
Q22-3	TRANSISTOR RF	BFW92A	TEK	BFW92A	29.160
Q23-3	TRANSISTOR AF	BC548 NPN T0-92	PHILIPS	BC548 (-A/-B/-C)	28.070
Q24-3	TRANSISTOR MOSFET	N-CHANNEL ENHANCEMENT	SILICONIX	SD210DE	29.719
Q25-3	TRANSISTOR RF SWITCH	2N2369A	MOTOROLA	2N2369A	28.315
Q26-3	TRANSISTOR RF SWITCH	2N2369A	MOTOROLA	2N2369A	28.315
Q27-3	TRANSISTOR RF	BF199	PHILIPS	BF199	28.178
Q28-3	TRANSISTOR AF	BC548 NPN T0-92	PHILIPS	BC548 (-A/-B/-C)	28.070
Q29-3	TRANSISTOR AF	BC548 NPN T0-92	PHILIPS	BC548 (-A/-B/-C)	28.070
Q30-3	TRANSISTOR JFET	T1S88A3 T0-92	MOTOROLA	TM 00 044-3	29.737
Q31-3	TRANSISTOR AF	BC558 PNP T0-92	PHILIPS	BC558 (-A/-B/-C)	28.095
Q32-3	TRANSISTOR AF	BC548 NPN T0-92	PHILIPS	BC548 (-A/-B/-C)	28.070
Q33-3	TRANSISTOR JFET	T1S88A3 T0-92	MOTOROLA	TM 00 044-3	29.737
Q34-3	TRANSISTOR RF	BF199	PHILIPS	BF199	28.178
Q35-3	TRANSISTOR AF	BC558 PNP T0-92	PHILIPS	BC558 (-A/-B/-C)	28.095
Q36-3	TRANSISTOR RF	BFW92A	TEK	BFW92A	29.160
Q37-3	TRANSISTOR RF	BFW92A	TEK	BFW92A	29.160
Q38-3	TRANSISTOR RF	BF199	PHILIPS	BF199	28.178
Q39-3	TRANSISTOR AF	BC548 NPN T0-92	PHILIPS	BC548 (-A/-B/-C)	28.070
Q40-3	TRANSISTOR RF	BF199	PHILIPS	BF199	28.178
R1-3	RESISTOR MF	100 OHM 5% 0.33W	PHILIPS	2322 180 73101	02.448
R2-3	RESISTOR MF	100 OHM 5% 0.33W	PHILIPS	2322 180 73101	02.448
R3-3	RESISTOR MF	100 OHM 5% 0.33W	PHILIPS	2322 180 73101	02.448
R4-3	RESISTOR MF	100 OHM 5% 0.33W	PHILIPS	2322 180 73101	02.448
R5-3	RESISTOR MF	100 OHM 5% 0.33W	PHILIPS	2322 180 73101	02.448
R6-3	RESISTOR MF	10k OHM 5% 0.33W	PHILIPS	2322 180 73103	02.496
R7-3	RESISTOR MF	10k OHM 5% 0.33W	PHILIPS	2322 180 73103	02.496
R8-3	RESISTOR MF	10k OHM 5% 0.33W	PHILIPS	2322 180 73103	02.496
R9-3	RESISTOR MF	5k6 OHM 5% 0.33W	PHILIPS	2322 180 73562	02.490
R10-3	RESISTOR MF	56 OHM 5% 0.33W	PHILIPS	2322 180 73569	02.442
R11-3	RESISTOR MF	910 OHM 5% 0.33W	PHILIPS	2322 180 73911	02.471
R12-3	RESISTOR MF	5k6 OHM 5% 0.33W	PHILIPS	2322 180 73562	02.490
R13-3	RESISTOR MF	10k OHM 5% 0.33W	PHILIPS	2322 180 73103	02.496
R14-3	RESISTOR MF	10k OHM 5% 0.33W	PHILIPS	2322 180 73103	02.496
R15-3	RESISTOR MF	10k OHM 5% 0.33W	PHILIPS	2322 180 73103	02.496
R16-3	RESISTOR MF	5k6 OHM 5% 0.33W	PHILIPS	2322 180 73562	02.490
R17-3	RESISTOR MF	330 OHM 5% 0.33W	PHILIPS	2322 180 73331	02.460
R18-3	RESISTOR MF	56 OHM 5% 0.33W	PHILIPS	2322 180 73569	02.442
R19-3	RESISTOR MF	910 OHM 5% 0.33W	PHILIPS	2322 180 73911	02.471
R20-3	RESISTOR MF	5k6 OHM 5% 0.33W	PHILIPS	2322 180 73562	02.490
R21-3	RESISTOR MF	10k OHM 5% 0.33W	PHILIPS	2322 180 73103	02.496

POSITION	DESCRIPTION	MANUFACTOR	TYPE	S.P. NUMBER
R22-3	RESISTOR MF	10k OHM 5% 0.33W	PHILIPS 2322 180 73103	02.496
R23-3	RESISTOR MF	10k OHM 5% 0.33W	PHILIPS 2322 180 73103	02.496
R24-3	RESISTOR MF	5k6 OHM 5% 0.33W	PHILIPS 2322 180 73562	02.490
R25-3	RESISTOR MF	56 OHM 5% 0.33W	PHILIPS 2322 180 73569	02.442
R26-3	RESISTOR MF	910 OHM 5% 0.33W	PHILIPS 2322 180 73911	02.471
R27-3	RESISTOR MF	5k6 OHM 5% 0.33W	PHILIPS 2322 180 73562	02.490
R28-3	RESISTOR MF	680 OHM 5% 0.33W	PHILIPS 2322 180 73681	02.468
R29-3	RESISTOR MF	10k OHM 5% 0.33W	PHILIPS 2322 180 73103	02.496
R30-3	RESISTOR MF	10k OHM 5% 0.33W	PHILIPS 2322 180 73103	02.496
R31-3	RESISTOR MF	680 OHM 5% 0.33W	PHILIPS 2322 180 73681	02.468
R32-3	RESISTOR MF	10k OHM 5% 0.33W	PHILIPS 2322 180 73103	02.496
R33-3	RESISTOR MF	8k2 OHM 5% 0.33W	PHILIPS 2322 180 73822	02.494
R34-3	RESISTOR MF	5k6 OHM 5% 0.33W	PHILIPS 2322 180 73562	02.490
R35-3	RESISTOR MF	56 OHM 5% 0.33W	PHILIPS 2322 180 73569	02.442
R36-3	RESISTOR MF	910 OHM 5% 0.33W	PHILIPS 2322 180 73911	02.471
R37-3	RESISTOR MF	5k6 OHM 5% 0.33W	PHILIPS 2322 180 73562	02.490
R38-3	RESISTOR MF	36k OHM 5% 0.33W	PHILIPS 2322 180 73363	02.509
R39-3	RESISTOR MF	5k6 OHM 5% 0.33W	PHILIPS 2322 180 73562	02.490
R40-3	RESISTOR MF	100 OHM 5% 0.33W	PHILIPS 2322 180 73101	02.448
R41-3	RESISTOR MF	100 OHM 5% 0.33W	PHILIPS 2322 180 73101	02.448
R42-3	RESISTOR MF	1k2 OHM 5% 0.33W	PHILIPS 2322 180 73122	02.474
R43-3	RESISTOR MF	56k2 OHM 1% 0.25W	PHILIPS 2322 157 15629	02.222
R44-3	RESISTOR MF	33k OHM 5% 0.33W	PHILIPS 2322 180 73333	02.508
R45-3	RESISTOR MF	12k OHM 5% 0.33W	PHILIPS 2322 180 73123	02.498
R46-3	RESISTOR MF	15k OHM 5% 0.33W	PHILIPS 2322 180 73153	02.500
R47-3	RESISTOR MF	82 OHM 5% 0.33W	PHILIPS 2322 180 73829	02.446
R48-3	RESISTOR MF	7k5 OHM 5% 0.33W	PHILIPS 2322 180 73752	02.493
R49-3	RESISTOR MF	10k OHM 5% 0.33W	PHILIPS 2322 180 73103	02.496
R50-3	RESISTOR MF	82 OHM 5% 0.33W	PHILIPS 2322 180 73829	02.446
R51-3	RESISTOR MF	10k OHM 5% 0.33W	PHILIPS 2322 180 73103	02.496
R52-3	RESISTOR MF	2k2 OHM 5% 0.33W	PHILIPS 2322 180 73222	02.480
R53-3	RESISTOR MF	2k2 OHM 5% 0.33W	PHILIPS 2322 180 73222	02.480
R54-3	RESISTOR MF	2k7 OHM 5% 0.33W	PHILIPS 2322 180 73272	02.482
R55-3	RESISTOR MF	12k OHM 5% 0.33W	PHILIPS 2322 180 73123	02.498
R56-3	RESISTOR MF	5k1 OHM 5% 0.33W	PHILIPS 2322 180 73512	02.489
R57-3	RESISTOR MF	10k OHM 5% 0.33W	PHILIPS 2322 180 73103	02.496
R58-3	RESISTOR MF	10k OHM 5% 0.33W	PHILIPS 2322 180 73103	02.496
R59-3	RESISTOR MF	12k OHM 5% 0.33W	PHILIPS 2322 180 73123	02.498
R60-3	RESISTOR MF	100 OHM 5% 0.33W	PHILIPS 2322 180 73101	02.448
R61-3	RESISTOR MF	220 OHM 5% 0.33W	PHILIPS 2322 180 73221	02.456
R62-3	RESISTOR MF	10 OHM 5% 0.33W	PHILIPS 2322 180 73109	02.424
R63-3	RESISTOR MF	680 OHM 5% 0.33W	PHILIPS 2322 180 73681	02.468
R64-3	RESISTOR MF	1k0 OHM 5% 0.33W	PHILIPS 2322 180 73102	02.472
R65-3	RESISTOR MF	390 OHM 5% 0.33W	PHILIPS 2322 180 73391	02.462

POSITION	DESCRIPTION	MANUFACTOR	TYPE	S.P. NUMBER
R66-3	RESISTOR MF	390 OHM 5% 0.33W	PHILIPS 2322 180 73391	02.462
R67-3	RESISTOR MF	5k6 OHM 5% 0.33W	PHILIPS 2322 180 73562	02.490
R68-3	RESISTOR MF	100 OHM 5% 0.33W	PHILIPS 2322 180 73101	02.448
R69-3	RESISTOR MF	82 OHM 5% 0.33W	PHILIPS 2322 180 73829	02.446
R70-3	RESISTOR MF	470 OHM 5% 0.33W	PHILIPS 2322 180 73471	02.464
R71-3	RESISTOR MF	1k0 OHM 5% 0.33W	PHILIPS 2322 180 73102	02.472
R72-3	RESISTOR MF	10k OHM 5% 0.33W	PHILIPS 2322 180 73103	02.496
R73-3	RESISTOR MF	10k OHM 5% 0.33W	PHILIPS 2322 180 73103	02.496
R74-3	RESISTOR MF	10k OHM 5% 0.33W	PHILIPS 2322 180 73103	02.496
R75-3	RESISTOR MF	10k OHM 5% 0.33W	PHILIPS 2322 180 73103	02.496
R76-3	RESISTOR MF	2k7 OHM 5% 0.33W	PHILIPS 2322 180 73272	02.482
R77-3	RESISTOR MF	220 OHM 5% 0.33W	PHILIPS 2322 180 73221	02.456
R78-3	RESISTOR MF	1k8 OHM 5% 0.33W	PHILIPS 2322 180 73182	02.478
R79-3	RESISTOR MF	33 OHM 5% 0.33W	PHILIPS 2322 180 73339	02.436
R80-3	RESISTOR MF	470 OHM 5% 0.4W	PHILIPS 2322 181 53471	01.191
R81-3	RESISTOR MF	56 OHM 5% 0.33W	PHILIPS 2322 180 73569	02.442
R82-3	RESISTOR MF	10 OHM 5% 0.33W	PHILIPS 2322 180 73109	02.424
R83-3	RESISTOR MF	100k OHM 5% 0.33W	PHILIPS 2322 180 73104	02.520
R84-3	RESISTOR MF	10k OHM 5% 0.33W	PHILIPS 2322 180 73103	02.496
R85-3	RESISTOR MF	10k OHM 5% 0.33W	PHILIPS 2322 180 73103	02.496
R86-3	RESISTOR MF	5k6 OHM 5% 0.33W	PHILIPS 2322 180 73562	02.490
R87-3	RESISTOR MF	2k32 OHM 1% 0.25W	PHILIPS 2322 157 12322	02.225
R88-3	PRESET CERMET	1k0 OHM 10% 0.5W	BOURNS 3386P-1-102	07.886
R89-3	RESISTOR MF	909 OHM 1% 0.25W	PHILIPS 2322 157 19091	02.218
R90-3	RESISTOR MF	681 OHM 1% 0.25W	PHILIPS 2322 157 16811	02.223
R91-3	RESISTOR MF	100 OHM 5% 0.33W	PHILIPS 2322 180 73101	02.448
R92-3	RESISTOR MF	100 OHM 5% 0.33W	PHILIPS 2322 180 73101	02.448
R93-3	RESISTOR MF	4k7 OHM 5% 0.33W	PHILIPS 2322 180 73472	02.488
R94-3	RESISTOR MF	100 OHM 5% 0.33W	PHILIPS 2322 180 73101	02.448
R95-3	RESISTOR MF	5k6 OHM 5% 0.33W	PHILIPS 2322 180 73562	02.490
R96-3	RESISTOR MF	1k2 OHM 5% 0.33W	PHILIPS 2322 180 73122	02.474
R97-3	RESISTOR MF	5k6 OHM 5% 0.33W	PHILIPS 2322 180 73562	02.490
R98-3	RESISTOR MF	5k6 OHM 5% 0.33W	PHILIPS 2322 180 73562	02.490
R100-3	RESISTOR MF	100 OHM 5% 0.33W	PHILIPS 2322 180 73101	02.448
R101-3	RESISTOR MF	100 OHM 5% 0.33W	PHILIPS 2322 180 73101	02.448
R102-3	RESISTOR MF	100 OHM 5% 0.33W	PHILIPS 2322 180 73101	02.448
R103-3	RESISTOR MF	470 OHM 5% 0.33W	PHILIPS 2322 180 73471	02.464
R104-3	RESISTOR MF	1k2 OHM 5% 0.33W	PHILIPS 2322 180 73122	02.474
R105-3	RESISTOR MF	220 OHM 5% 0.33W	PHILIPS 2322 180 73221	02.456
R106-3	RESISTOR MF	15k OHM 5% 0.33W	PHILIPS 2322 180 73153	02.500
R107-3	RESISTOR MF	56 OHM 5% 0.33W	PHILIPS 2322 180 73569	02.442
R108-3	RESISTOR MF	56 OHM 5% 0.33W	PHILIPS 2322 180 73569	02.442
R109-3	RESISTOR MF	560 OHM 5% 0.33W	PHILIPS 2322 180 73561	02.466
R110-3	RESISTOR MF	2k2 OHM 5% 0.33W	PHILIPS 2322 180 73222	02.480

POSITION	DESCRIPTION		MANUFACTOR	TYPE	S.P.NUMBER
R111-3	RESISTOR MF	4k7 OHM 5% 0.33W	PHILIPS	2322 180 73472	02.488
R112-3	RESISTOR MF	6k8 OHM 5% 0.33W	PHILIPS	2322 180 73682	02.492
R113-3	RESISTOR MF	10k OHM 5% 0.33W	PHILIPS	2322 180 73103	02.496
R114-3	RESISTOR MF	10k OHM 5% 0.33W	PHILIPS	2322 180 73103	02.496
R115-3	RESISTOR MF	220 OHM 5% 0.33W	PHILIPS	2322 180 73221	02.456
R116-3	RESISTOR MF	10k OHM 5% 0.33W	PHILIPS	2322 180 73103	02.496
R117-3	RESISTOR MF	10k OHM 5% 0.33W	PHILIPS	2322 180 73103	02.496
R118-3	RESISTOR MF	300 OHM 5% 0.33W	PHILIPS	2322 180 73301	02.459
R119-3	RESISTOR MF	10k OHM 5% 0.33W	PHILIPS	2322 180 73103	02.496
R120-3	RESISTOR MF	56k OHM 5% 0.33W	PHILIPS	2322 180 73563	02.514
R121-3	RESISTOR MF	10k OHM 5% 0.33W	PHILIPS	2322 180 73103	02.496
R122-3	RESISTOR MF	300 OHM 5% 0.33W	PHILIPS	2322 180 73301	02.459
R123-3	RESISTOR MF	36k OHM 5% 0.33W	PHILIPS	2322 180 73363	02.509
R124-3	RESISTOR MF	1k0 OHM 5% 0.33W	PHILIPS	2322 180 73102	02.472
R125-3	RESISTOR MF	270 OHM 5% 0.33W	PHILIPS	2322 180 73271	02.458
R126-3	RESISTOR MF	100 OHM 5% 0.33W	PHILIPS	2322 180 73101	02.448
R127-3	RESISTOR MF	18k OHM 5% 0.33W	PHILIPS	2322 180 73183	02.502
R128-3	RESISTOR MF	36k OHM 5% 0.33W	PHILIPS	2322 180 73363	02.509
R129-3	RESISTOR MF	56k OHM 5% 0.33W	PHILIPS	2322 180 73562	02.490
R130-3	RESISTOR MF	18k OHM 5% 0.33W	PHILIPS	2322 180 73183	02.502
R131-3	RESISTOR MF	10k OHM 5% 0.33W	PHILIPS	2322 180 73103	02.496
R132-3	RESISTOR MF	10k OHM 5% 0.33W	PHILIPS	2322 180 73103	02.496
R133-3	RESISTOR MF	56k OHM 5% 0.33W	PHILIPS	2322 180 73563	02.514
R134-3	RESISTOR MF	10k OHM 5% 0.33W	PHILIPS	2322 180 73103	02.496
R135-3	RESISTOR MF	1k0 OHM 5% 0.33W	PHILIPS	2322 180 73102	02.472
R136-3	RESISTOR MF	270 OHM 5% 0.33W	PHILIPS	2322 180 73271	02.458
R137-3	RESISTOR MF	100 OHM 5% 0.33W	PHILIPS	2322 180 73101	02.448
R138-3	RESISTOR MF	47 OHM 5% 0.33W	PHILIPS	2322 180 73479	02.440
R139-3	RESISTOR MF	100 OHM 5% 0.33W	PHILIPS	2322 180 73101	02.448
R140-3	RESISTOR MF	100 OHM 5% 0.33W	PHILIPS	2322 180 73101	02.448
R141-3	RESISTOR MF	100k OHM 5% 0.33W	PHILIPS	2322 180 73104	02.520
R142-3	RESISTOR MF	100 OHM 5% 0.33W	PHILIPS	2322 180 73101	02.448
R143-3	RESISTOR MF	220 OHM 5% 0.33W	PHILIPS	2322 180 73221	02.456
R144-3	RESISTOR MF	10 OHM 5% 0.33W	PHILIPS	2322 180 73109	02.424
R145-3	RESISTOR MF	1k0 OHM 5% 0.33W	PHILIPS	2322 180 73102	02.472
R146-3	RESISTOR MF	100 OHM 5% 0.33W	PHILIPS	2322 180 73101	02.448
R147-3	RESISTOR MF	56k OHM 5% 0.33W	PHILIPS	2322 180 73562	02.490
R148-3	RESISTOR MF	100k OHM 5% 0.33W	PHILIPS	2322 180 73104	02.520
R150-3	RESISTOR MF	56k OHM 5% 0.33W	PHILIPS	2322 180 73562	02.490
R151-3	RESISTOR MF	100 OHM 5% 0.33W	PHILIPS	2322 180 73101	02.448
R152-3	RESISTOR MF	100 OHM 5% 0.33W	PHILIPS	2322 180 73101	02.448
R153-3	RESISTOR MF	1k2 OHM 5% 0.33W	PHILIPS	2322 180 73122	02.474
R154-3	RESISTOR MF	470 OHM 5% 0.33W	PHILIPS	2322 180 73471	02.464
R155-3	RESISTOR MF	1k0 OHM 5% 0.33W	PHILIPS	2322 180 73102	02.472

POSITION	DESCRIPTION		MANUFACTOR	TYPE	S.P.NUMBER
R156-3	RESISTOR MF	2k7 OHM 5% 0.33W	PHILIPS	2322 180 73272	02.482
R157-3	RESISTOR MF	47 OHM 5% 0.33W	PHILIPS	2322 180 73479	02.440
R158-3	RESISTOR MF	390 OHM 5% 0.4W	PHILIPS	2322 181 53391	01.189
R159-3	RESISTOR MF	82 OHM 5% 0.33W	PHILIPS	2322 180 73829	02.446
R160-3	RESISTOR MF	100 OHM 5% 0.33W	PHILIPS	2322 180 73101	02.448
R161-3	RESISTOR MF	100k OHM 5% 0.33W	PHILIPS	2322 180 73104	02.520
R162-3	RESISTOR MF	2k2 OHM 5% 0.33W	PHILIPS	2322 180 73222	02.480
R163-3	RESISTOR MF	10k OHM 5% 0.33W	PHILIPS	2322 180 73103	02.496
R164-3	RESISTOR MF	10k OHM 5% 0.33W	PHILIPS	2322 180 73103	02.496
R165-3	RESISTOR MF	56k OHM 5% 0.33W	PHILIPS	2322 180 73562	02.490
R166-3	RESISTOR MF	10k OHM 5% 0.33W	PHILIPS	2322 180 73103	02.496
R167-3	RESISTOR MF	390 OHM 5% 0.33W	PHILIPS	2322 180 73391	02.462
R168-3	RESISTOR MF	390 OHM 5% 0.33W	PHILIPS	2322 180 73391	02.462
R169-3	RESISTOR MF	100 OHM 5% 0.33W	PHILIPS	2322 180 73101	02.448
R170-3	RESISTOR MF	82 OHM 5% 0.33W	PHILIPS	2322 180 73829	02.446
R171-3	RESISTOR MF	10k OHM 5% 0.33W	PHILIPS	2322 180 73103	02.496
R172-3	RESISTOR MF	10k OHM 5% 0.33W	PHILIPS	2322 180 73103	02.496
R173-3	RESISTOR MF	1k8 OHM 5% 0.33W	PHILIPS	2322 180 73182	02.478
R174-3	RESISTOR MF	15k OHM 5% 0.33W	PHILIPS	2322 180 73153	02.500
R175-3	RESISTOR MF	56 OHM 5% 0.33W	PHILIPS	2322 180 73569	02.442
R176-3	RESISTOR MF	2k2 OHM 5% 0.33W	PHILIPS	2322 180 73222	02.480
R177-3	RESISTOR MF	47 OHM 5% 0.33W	PHILIPS	2322 180 73479	02.440
R178-3	RESISTOR MF	33 OHM 5% 0.33W	PHILIPS	2322 180 73339	02.436
R182-3	RESISTOR MF	56 OHM 5% 0.33W	PHILIPS	2322 180 73569	02.442
R183-3	RESISTOR MF	220 OHM 5% 0.33W	PHILIPS	2322 180 73221	02.456
R184-3	RESISTOR MF	220 OHM 5% 0.33W	PHILIPS	2322 180 73221	02.456
R185-3	RESISTOR MF	150 OHM 5% 0.33W	PHILIPS	2322 180 73151	02.452
R186-3	RESISTOR MF	150 OHM 5% 0.33W	PHILIPS	2322 180 73151	02.452
R187-3	RESISTOR MF	10 OHM 5% 0.33W	PHILIPS	2322 180 73109	02.424
R188-3	RESISTOR MF	10 OHM 5% 0.33W	PHILIPS	2322 180 73109	02.424
RE1-3	RELAY	15V DC 2A 1SH.	SIEMENS	V23040-A0003-B201	21.062
RE2-3	RELAY	15V DC 2A 1SH.	SIEMENS	V23040-A0003-B201	21.062
TR1-3	TRANSFORMER	TL493	S.P.RADIO	6-0-25812	400493
TR2-3	TRANSFORMER	TL493	S.P.RADIO	6-0-25812	400493
TR3-3	TRANSFORMER RF	70nH ADJUSTABLE	TOKO	E526HN-110440	38.408
TR4-3	TRANSFORMER RF	70nH ADJUSTABLE	TOKO	E526HN-110440	38.408
TR5-3	TRANSFORMER RF	110nH ADJUSTABLE	TOKO	E526-110436	38.407
TR6-3	TRANSFORMER RF	110nH ADJUSTABLE	TOKO	E526-110436	38.407
TR7-3	TRANSFORMER RF	70nH ADJUSTABLE	TOKO	E526HN-110440	38.408
TR8-3	TRANSFORMER RF	110nH ADJUSTABLE	TOKO	E526-110436	38.407
U1-3	INTEGRATED CIRCUIT	8 BIT SHIFT REG.SERIAL IO	NATIONAL	MM74HC595N	34.502
U2-3	HEX D-FLIP-FLOP w.CLEAR	74HC174	TEXAS	SN74HC174N	34.504
U3-3	INTEGRATED CIRCUIT	8 BIT SHIFT REG.SERIAL IO	NATIONAL	MM74HC595N	34.502
U4-3	4-BIT BINARY FULL ADDERS	WITH FAST CARRY	TEXAS	SN74HC283N	34.540

POSITION	DESCRIPTION		MANUFACTURER	TYPE	S.P. NUMBER
U5-3	VOLTAGE REGULATOR	-15V 5% 0.1A	MOTOROLA	MC79L15ACP	31.143
U6-3	VOLTAGE REGULATOR	15V 5% 0.1A	MOTOROLA	MC78L15ACP	31.140
U7-3	4-BIT BINARY FULL ADDERS	WITH FAST CARRY	TEXAS	SN74HC283N	34.540
U8-3	HEX D-FLIP-FLOP w. CLEAR	74HC174	TEXAS	SN74HC174N	34.504
U9-3	INTEGRATED CIRCUIT	8 BIT SHIFT REG. SERIAL IO	NATIONAL	MM74HC595N	34.502
U10-3	VOLTAGE REGULATOR	12V 5% 0.1A	MOTOROLA	MC78L12ACP	31.139
U11-3	VOLTAGE REGULATOR	15V 5% 0.1A	MOTOROLA	MC78L15ACP	31.140
U12-3	4-BIT BINARY FULL ADDERS	WITH FAST CARRY	TEXAS	SN74HC283N	34.540
U13-3	INTEGRATED CIRCUIT	DUAL D-FF POS. TRIG.	TEXAS	SN74HC74N	34.501
U14-3	12-BIT D/A CONVERTER		NATIONAL	DAC1220LCN	32.810
U15-3	8-BIT BINARY COUNTERS	WITH 3-STATE OUTPUT REG.	TEXAS	SN74HC590N	34.530
U16-3	OPERATIONAL AMPLIFIER	JFET INPUT LF356	NATIONAL	LF356N	31.076
U17-3	INTEGRATED CIRCUIT	HEX INVERTERS	TEXAS	SN74HC04N	34.520
U18-3	OPERATIONAL AMPLIFIER	JFET INPUT LF356	NATIONAL	LF356N	31.076
U19-3	OPERATIONAL AMPLIFIER	JFET INPUT LF356	NATIONAL	LF356N	31.076
U20-3	TRANSISTOR ARRAY	3046	NATIONAL	LM3046N	31.025
U21-3	OPERATIONAL AMPLIFIER	JFET INPUT LF356	NATIONAL	LF356N	31.076
U22-3	32/33 MODULUS PRESCALER		PLESSEY	SP8795BDP	32.851
U23-3	QUAD 2-INPUT POS. AND GATE		TEXAS	SN74HC08N	34.517
U24-3	INTEGRATED CIRCUIT	SERIAL INPUT PLL SYNTHES.	MOTOROLA	MC145158P2	33.492
U25-3	QUAD EXCL. NOR GATE	74HC266	TEXAS	SN74HC266N	34.500
U26-3	INTEGRATED CIRCUIT	DUAL D-FF POS. TRIG.	TEXAS	SN74HC74N	34.501
U27-3	INTEGRATED CIRCUIT	QUAD 2-INPUT NAND GATE	TEXAS	SN74HC00N	34.515
U28-3	INTEGRATED CIRCUIT	DUAL D-FF POS. TRIG.	TEXAS	SN74HC74N	34.501
U29-3	INTEGRATED CIRCUIT	QUAD 2-INPUT NAND GATE	TEXAS	SN74HC00N	34.515
U30-3	INTEGRATED CIRCUIT	SERIAL INPUT PLL SYNTHES.	MOTOROLA	MC145158P2	33.492
U31-3	INTEGRATED CIRCUIT	DUAL D-FF POS. TRIG.	TEXAS	SN74HC74N	34.501
U32-3	8-BIT BINARY COUNTERS	WITH 3-STATE OUTPUT REG.	TEXAS	SN74HC590N	34.530
U33-3	VOLTAGE REGULATOR	15V 5% 0.1A	MOTOROLA	MC78L15ACP	31.140
U34-3	OPERATIONAL AMPLIFIER	JFET INPUT LF356	NATIONAL	LF356N	31.076
U35-3	INTEGRATED CIRCUIT	SERIAL INPUT PLL SYNTHES.	MOTOROLA	MC145158P2	33.492
U36-3	32/33 MODULUS PRESCALER		PLESSEY	SP8795BDP	32.851

POSITION	DESCRIPTION		MANUFACTOR	TYPE	S.P.NUMBER
	EXCITER MODULE 4	RE2100	ESPERA	5-0-25634C	625634
C1-4	CAPACITOR MKT	470nF 5% 63VDC	PHILIPS	2222 370 79474	11.187
C2-4	CAPACITOR MKT	220nF 20% 63VDC	ERO	MKT 1826-422/06 6-6	11.183
C3-4	CAPACITOR MKT	220nF 20% 63VDC	ERO	MKT 1826-422/06 6-6	11.183
C4-4	CAPACITOR MKT	220nF 20% 63VDC	ERO	MKT 1826-422/06 6-6	11.183
C5-4	CAPACITOR ELECTROLYTIC	4.7uF 20% 50VDC	ERO	EKI 00 AA 147 H M9	14.510
C6-4	CAPACITOR CERAMIC	10nF -20/+80% CL2 50VDC	KCK	RT-HE70 SK YF 103 Z AMMO PACK	15.170
C7-4	CAPACITOR CERAMIC	10nF -20/+80% CL2 50VDC	KCK	RT-HE70 SK YF 103 Z AMMO PACK	15.170
C8-4	CAPACITOR ELECTROLYTIC	220uF -20/+50% 25VDC	ERO	EKM 05 DD 322 E 05	14.647
C9-4	CAPACITOR CERAMIC	68pF 5% N150 50VDC	NKE	DT 380 758S PH 680 J 50V FLAT PACK	15.115
C10-4	CAPACITOR ELECTROLYTIC	4.7uF 20% 50VDC	ERO	EKI 00 AA 147 H M9	14.510
C11-4	CAPACITOR CERAMIC	10nF -20/+80% CL2 50VDC	KCK	RT-HE70 SK YF 103 Z AMMO PACK	15.170
C12-4	CAPACITOR CERAMIC	10nF -20/+80% CL2 50VDC	KCK	RT-HE70 SK YF 103 Z AMMO PACK	15.170
C13-4	CAPACITOR CERAMIC	10nF -20/+80% CL2 50VDC	KCK	RT-HE70 SK YF 103 Z AMMO PACK	15.170
C14-4	CAPACITOR CERAMIC	10nF -20/+80% CL2 50VDC	KCK	RT-HE70 SK YF 103 Z AMMO PACK	15.170
C15-4	CAPACITOR MKT	0.1uF 10% 63VDC	PHILIPS	2222 370 78104	11.136
C16-4	CAPACITOR MKT	220nF 20% 63VDC	ERO	MKT 1826-422/06 6-6	11.183
C17-4	CAPACITOR ELECTROLYTIC	22uF 20% 25VDC	ELNA	RJ2-25-V-220-M-T34	14.514
C18-4	CAPACITOR ELECTROLYTIC	100uF 20% 35VDC	ERO	EKI 00 AA 210 F M9	14.512
C19-4	CAPACITOR ELECTROLYTIC	4.7uF 20% 50VDC	ERO	EKI 00 AA 147 H M9	14.510
C20-4	CAPACITOR ELECTROLYTIC	47uF 20% 25VDC	ERO	EKI 00 BB 247 E M9	14.524
C21-4	CAPACITOR MKT	0.1uF 10% 63VDC	PHILIPS	2222 370 78104	11.136
C22-4	CAPACITOR MKT	220nF 20% 63VDC	ERO	MKT 1826-422/06 6-6	11.183
C23-4	CAPACITOR ELECTROLYTIC	100uF -10/+50% 25VDC	ERO	EKM 00 CC 310 E 65	14.610
C24-4	CAPACITOR CERAMIC	10nF 10% CL2 50VDC	KCK	RT-HM60 SK YB 102 K AMMO PACK	15.160
C25-4	CAPACITOR ELECTROLYTIC	3.3uF 20% 50VDC	ERO	EKI 00 AA 133 H M9	14.508
C26-4	CAPACITOR MKT	0.1uF 10% 63VDC	PHILIPS	2222 370 78104	11.136
C27-4	CAPACITOR MKT	220nF 20% 63VDC	ERO	MKT 1826-422/06 6-6	11.183
C28-4	CAPACITOR ELECTROLYTIC	100uF -10/+50% 25VDC	ERO	EKM 00 CC 310 E 65	14.610
C29-4	CAPACITOR MKT	0.1uF 10% 63VDC	PHILIPS	2222 370 78104	11.136
C30-4	CAPACITOR MKT	470nF 5% 63VDC	PHILIPS	2222 370 79474	11.187
C31-4	CAPACITOR ELECTROLYTIC	1uF 20% 50VDC	ERO	EKI 00 AA 110 H M9	14.506
C32-4	CAPACITOR ELECTROLYTIC	1uF 20% 50VDC	ERO	EKI 00 AA 110 H M9	14.506
C33-4	CAPACITOR MKT	0.1uF 10% 63VDC	PHILIPS	2222 370 78104	11.136

POSITION	DESCRIPTION		MANUFACTOR	TYPE	S.P.NUMBER
C34-4	CAPACITOR MKT	220nF 20% 63VDC	ERO	MKT 1826-422/06 6-6	11.183
C35-4	CAPACITOR ELECTROLYTIC	100uF -10/+50% 25VDC	ERO	EKM 00 CC 310 E 65	14.610
C36-4	CAPACITOR ELECTROLYTIC	4.7uF 20% 50VDC	ERO	EKI 00 AA 147 H M9	14.510
C37-4	CAPACITOR MKT	220nF 20% 63VDC	ERO	MKT 1826-422/06 6-6	11.183
C38-4	CAPACITOR ELECTROLYTIC	4.7uF 20% 50VDC	ERO	EKI 00 AA 147 H M9	14.510
C39-4	CAPACITOR ELECTROLYTIC	22uF 20% 25VDC	ELNA	RJ2-25-V-220-M-T34	14.514
C40-4	CAPACITOR MKT	0.1uF 10% 63VDC	PHILIPS	2222 370 78104	11.136
C41-4	CAPACITOR CERAMIC	10nF -20/+80% CL2 50VDC	KCK	RT-HE70 SK YF 103 Z AMMO PACK	15.170
C42-4	CAPACITOR CERAMIC	10nF -20/+80% CL2 50VDC	KCK	RT-HE70 SK YF 103 Z AMMO PACK	15.170
C43-4	CAPACITOR ELECTROLYTIC	22uF 20% 25VDC	ELNA	RJ2-25-V-220-M-T34	14.514
C44-4	CAPACITOR MKT	0.1uF 10% 63VDC	PHILIPS	2222 370 78104	11.136
C45-4	CAPACITOR MKT	0.1uF 10% 63VDC	PHILIPS	2222 370 78104	11.136
C46-4	CAPACITOR MKT	22nF 5% 100VDC	PHILIPS	2222 370 89223	11.169
C47-4	CAPACITOR POLYSTYRENE	100pF 1% 630VDC	PHILIPS	2222 431 81001	10.400
C48-4	CAPACITOR CERAMIC	10nF -20/+80% CL2 50VDC	KCK	RT-HE70 SK YF 103 Z AMMO PACK	15.170
C49-4	CAPACITOR CERAMIC	10nF -20/+80% CL2 50VDC	KCK	RT-HE70 SK YF 103 Z AMMO PACK	15.170
C50-4	CAPACITOR CERAMIC	10nF -20/+80% CL2 50VDC	KCK	RT-HE70 SK YF 103 Z AMMO PACK	15.170
C51-4	CAPACITOR CERAMIC	68pF 5% N150 50VDC	NKE	DT 380 758S PH 680 J 50V FLAT PACK	15.115
C52-4	CAPACITOR CERAMIC	10nF -20/+80% CL2 50VDC	KCK	RT-HE70 SK YF 103 Z AMMO PACK	15.170
C53-4	CAPACITOR MKT	22nF 5% 100VDC	PHILIPS	2222 370 89223	11.169
C54-4	CAPACITOR CERAMIC	10nF -20/+80% CL2 50VDC	KCK	RT-HE70 SK YF 103 Z AMMO PACK	15.170
C55-4	CAPACITOR CERAMIC	10nF -20/+80% CL2 50VDC	KCK	RT-HE70 SK YF 103 Z AMMO PACK	15.170
C56-4	CAPACITOR ELECTROLYTIC	3.3uF 20% 50VDC	ERO	EKI 00 AA 133 H M9	14.508
C57-4	CAPACITOR CERAMIC	10nF -20/+80% CL2 50VDC	KCK	RT-HE70 SK YF 103 Z AMMO PACK	15.170
C58-4	CAPACITOR MKT	22nF 5% 100VDC	PHILIPS	2222 370 89223	11.169
C59-4	CAPACITOR CERAMIC	10nF -20/+80% CL2 50VDC	KCK	RT-HE70 SK YF 103 Z AMMO PACK	15.170
C60-4	CAPACITOR CERAMIC	39pF 5% N150 50VDC	NKE	DT 360 758L PH 390 J 50V FLAT PACK	15.090
C61-4	CAPACITOR CERAMIC	10nF -20/+80% CL2 50VDC	KCK	RT-HE70 SK YF 103 Z AMMO PACK	15.170
C63-4	CAPACITOR CERAMIC	10nF -20/+80% CL2 50VDC	KCK	RT-HE70 SK YF 103 Z AMMO PACK	15.170
C64-4	CAPACITOR CERAMIC	10nF -20/+80% CL2 50VDC	KCK	RT-HE70 SK YF 103 Z AMMO PACK	15.170

POSITION	DESCRIPTION		MANUFACTOR	TYPE	S.P.NUMBER
C65-4	CAPACITOR MKT	22nF 5% 100VDC	PHILIPS	AMMO PACK 2222 370 89223	11.169
C66-4	CAPACITOR MKT	22nF 5% 100VDC	PHILIPS	2222 370 89223	11.169
C67-4	CAPACITOR POLYSTYRENE	360pF 1% 630VDC	PHILIPS	2222 431 83601	10.418
C68-4	CAPACITOR MKT	22nF 5% 100VDC	PHILIPS	2222 370 89223	11.169
C69-4	CAPACITOR POLYSTYRENE	220pF 1% 630VDC	PHILIPS	2222 431 82201	10.409
C70-4	CAPACITOR CERAMIC	10nF -20/+80% CL2 50VDC	KCK	RT-HE70 SK YF 103 Z AMMO PACK	15.170
C71-4	CAPACITOR CERAMIC	10nF -20/+80% CL2 50VDC	KCK	RT-HE70 SK YF 103 Z AMMO PACK	15.170
C72-4	CAPACITOR CERAMIC	10nF -20/+80% CL2 50VDC	KCK	RT-HE70 SK YF 103 Z AMMO PACK	15.170
C73-4	CAPACITOR CERAMIC	10nF -20/+80% CL2 50VDC	KCK	RT-HE70 SK YF 103 Z AMMO PACK	15.170
C75-4	CAPACITOR CERAMIC	10nF -20/+80% CL2 50VDC	KCK	RT-HE70 SK YF 103 Z AMMO PACK	15.170
C76-4	CAPACITOR CERAMIC	10nF -20/+80% CL2 50VDC	KCK	RT-HE70 SK YF 103 Z AMMO PACK	15.170
C77-4	CAPACITOR CERAMIC	10nF -20/+80% CL2 50VDC	KCK	RT-HE70 SK YF 103 Z AMMO PACK	15.170
C78-4	CAPACITOR CERAMIC	10nF -20/+80% CL2 50VDC	KCK	RT-HE70 SK YF 103 Z AMMO PACK	15.170
C79-4	CAPACITOR CERAMIC	10nF -20/+80% CL2 50VDC	KCK	RT-HE70 SK YF 103 Z AMMO PACK	15.170
C80-4	CAPACITOR CERAMIC	10nF -20/+80% CL2 50VDC	KCK	RT-HE70 SK YF 103 Z AMMO PACK	15.170
C81-4	CAPACITOR CERAMIC	10nF -20/+80% CL2 50VDC	KCK	RT-HE70 SK YF 103 Z AMMO PACK	15.170
C82-4	CAPACITOR MKT	220nF 20% 63VDC	ERO	MKT 1826-422/06 6-G	11.183
C83-4	CAPACITOR CERAMIC	10nF -20/+80% CL2 50VDC	KCK	RT-HE70 SK YF 103 Z AMMO PACK	15.170
C84-4	CAPACITOR POLYSTYRENE	430pF 1% 630VDC	PHILIPS	2222 431 84301	10.428
C85-4	CAPACITOR POLYSTYRENE	470pF 1% 630VDC	PHILIPS	2222 431 84701	10.429
C86-4	CAPACITOR MKT	22nF 5% 100VDC	PHILIPS	2222 370 89223	11.169
C87-4	CAPACITOR CERAMIC	10nF -20/+80% CL2 50VDC	KCK	RT-HE70 SK YF 103 Z AMMO PACK	15.170
C88-4	CAPACITOR CERAMIC	10nF -20/+80% CL2 50VDC	KCK	RT-HE70 SK YF 103 Z AMMO PACK	15.170
C89-4	CAPACITOR CERAMIC	10nF -20/+80% CL2 50VDC	KCK	RT-HE70 SK YF 103 Z AMMO PACK	15.170
C90-4	CAPACITOR CERAMIC	1n0F 10% CL2 500VDC	KCK	RT-HM60 SK YB 102 K AMMO PACK	15.160
C91-4	CAPACITOR CERAMIC	4p7F +/-0.25pF N750 50VDC	NKE	DT 330 758S UJ 4R7 C 50V FLAT PACK	15.872

POSITION	DESCRIPTION		MANUFACTOR	TYPE	S.P.NUMBER
C92-4	CAPACITOR CERAMIC	10nF -20/+80% CL2 50VDC	KCK	RT-HE70 SK YF 103 Z AMMO PACK	15.170
C93-4	CAPACITOR MKT	22nF 5% 100VDC	PHILIPS	2222 370 89223	11.169
C94-4	CAPACITOR CERAMIC	470pF 10% 500VDC	KCK	RT-HM60 SK YB 471 K AMMO PACK	16.095
C95-4	CAPACITOR ELECTROLYTIC	4.7uF 20% 50VDC	ERO	EKI 100 AA 147 H M9	14.510
C96-4	CAPACITOR MKT	22nF 5% 100VDC	PHILIPS	2222 370 89223	11.169
C97-4	CAPACITOR MKT	22nF 5% 100VDC	PHILIPS	2222 370 89223	11.169
C98-4	CAPACITOR CERAMIC	10nF -20/+80% CL2 50VDC	KCK	RT-HE70 SK YF 103 Z AMMO PACK	15.170
C99-4	CAPACITOR MKT	220nF 20% 63VDC	ERO	MKT 1826-422/06 6-G	11.183
C100-4	CAPACITOR MKT	22nF 5% 100VDC	PHILIPS	2222 370 89223	11.169
C101-4	CAPACITOR MKT	22nF 5% 100VDC	PHILIPS	2222 370 89223	11.169
C102-4	CAPACITOR MKT	22nF 5% 100VDC	PHILIPS	2222 370 89223	11.169
C103-4	CAPACITOR CERAMIC	470pF 10% 500VDC	KCK	RT-HM60 SK YB 471 K AMMO PACK	16.095
C104-4	CAPACITOR CERAMIC	5p6F +/-0.5pF N150 50VDC	NKE	DT 330 758S PH 5R6 D 50V FLAT PACK	15.013
C105-4	CAPACITOR MKT	220nF 20% 63VDC	ERO	MKT 1826-422/06 6-G	11.183
C106-4	CAPACITOR MKT	220nF 20% 63VDC	ERO	MKT 1826-422/06 6-G	11.183
C107-4	CAPACITOR MKT	22nF 5% 100VDC	PHILIPS	2222 370 89223	11.169
C108-4	CAPACITOR CERAMIC	470pF 10% 500VDC	KCK	RT-HM60 SK YB 471 K AMMO PACK	16.095
C109-4	CAPACITOR CERAMIC	8p2F +/-0.5pF N750 50VDC	NKE	DT 330 758S UJ 8R2 D 50V FLAT PACK	16.055
C110-4	CAPACITOR CERAMIC	27pF 10% N750 500VDC	NKE	DT35-D-465 758S UJ 270 K 500V - FLAT PACK	16.062
C111-4	CAPACITOR CERAMIC	10nF -20/+80% CL2 50VDC	KCK	RT-HE70 SK YF 103 Z AMMO PACK	15.170
C112-4	CAPACITOR MKT	22nF 5% 100VDC	PHILIPS	2222 370 89223	11.169
C113-4	CAPACITOR POLYSTYRENE	620pF 1% 250VDC	PHILIPS	2222 430 86201	10.345
C114-4	CAPACITOR POLYSTYRENE	750pF 1% 250VDC	PHILIPS	2222 430 87501	10.347
C115-4	CAPACITOR MKT	4n7F 10% 63VDC	PHILIPS	2222 370 88472	11.374
C116-4	CAPACITOR MKT	22nF 5% 100VDC	PHILIPS	2222 370 89223	11.169
C117-4	CAPACITOR MKT	22nF 5% 100VDC	PHILIPS	2222 370 89223	11.169
C118-4	CAPACITOR MKT	4n7F 10% 63VDC	PHILIPS	2222 370 88472	11.374
C119-4	CAPACITOR MKT	22nF 5% 100VDC	PHILIPS	2222 370 89223	11.169
C120-4	CAPACITOR MKT	2n2F 10% 400VDC	ERO	MKT 1818-222/63 5-G	11.143
C121-4	CAPACITOR MKT	22nF 5% 100VDC	PHILIPS	2222 370 89223	11.169
C122-4	CAPACITOR CERAMIC	10nF -20/+80% CL2 50VDC	KCK	RT-HE70 SK YF 103 Z AMMO PACK	15.170
C123-4	CAPACITOR CERAMIC	10nF -20/+80% CL2 50VDC	KCK	RT-HE70 SK YF 103 Z AMMO PACK	15.170
C124-4	CAPACITOR MKT	22nF 5% 100VDC	PHILIPS	2222 370 89223	11.169



POSITION	DESCRIPTION		MANUFACTOR	TYPE	S.P. NUMBER
C125-4	CAPACITOR MKT	22nF 5% 100VDC	PHILIPS	2222 370 89223	11.169
C126-4	CAPACITOR MKT	2nF 10% 400VDC	ERO	MKT 1818-222/63 5-G	11.143
C127-4	CAPACITOR MKT	22nF 5% 100VDC	PHILIPS	2222 370 89223	11.169
C128-4	CAPACITOR MKT	22nF 5% 100VDC	PHILIPS	2222 370 89223	11.169
C129-4	CAPACITOR MKT	22nF 5% 100VDC	PHILIPS	2222 370 89223	11.169
C130-4	CAPACITOR ELECTROLYTIC	47uF 20% 25VDC	ERO	EKI 00 BB 247 E M9	14.524
C131-4	CAPACITOR CERAMIC	10nF -20/+80% CL2 50VDC	KCK	RT-HE70 SK YF 103 Z AMMO PACK	15.170
C132-4	CAPACITOR CERAMIC	10nF -20/+80% CL2 50VDC	KCK	RT-HE70 SK YF 103 Z AMMO PACK	15.170
C133-4	CAPACITOR CERAMIC	10nF -20/+80% CL2 50VDC	KCK	RT-HE70 SK YF 103 Z AMMO PACK	15.170
C134-4	CAPACITOR MKT	22nF 5% 100VDC	PHILIPS	2222 370 89223	11.169
C135-4	CAPACITOR CERAMIC	10nF -20/+80% CL2 50VDC	KCK	RT-HE70 SK YF 103 Z AMMO PACK	15.170
C136-4	CAPACITOR CERAMIC	10nF -20/+80% CL2 50VDC	KCK	RT-HE70 SK YF 103 Z AMMO PACK	15.170
D1-4	DIODE	1N4148 HIGH SPEED	PHILIPS	1N4148-143	25.131
D2-4	DIODE ZENER	5.6V 2% 0.4W	PHILIPS	BZX79B5V6	26.500
D3-4	DIODE	1N4148 HIGH SPEED	PHILIPS	1N4148-143	25.131
D4-4	DIODE	1N4148 HIGH SPEED	PHILIPS	1N4148-143	25.131
D5-4	DIODE	1N4148 HIGH SPEED	PHILIPS	1N4148-143	25.131
D6-4	DIODE SWITCH	BA243	TEK	BA243	25.386
D7-4	DIODE SWITCH	BA243	TEK	BA243	25.386
D8-4	DIODE	1N4148 HIGH SPEED	PHILIPS	1N4148-143	25.131
D9-4	DIODE	1N4148 HIGH SPEED	PHILIPS	1N4148-143	25.131
D10-4	DIODE SWITCH	BA243	TEK	BA243	25.386
D11-4	DIODE SWITCH	BA243	TEK	BA243	25.386
D12-4	DIODE SWITCH	BA243	TEK	BA243	25.386
D13-4	DIODE ZENER	4.7V 5% 0.4W	PHILIPS	BZX79C4V7	26.524
D14-4	DIODE SWITCH	BA243	TEK	BA243	25.386
D15-4	DIODE SWITCH	BA243	TEK	BA243	25.386
D16-4	DIODE ZENER	4.7V 5% 0.4W	PHILIPS	BZX79C4V7	26.524
D17-4	DIODE ZENER	4.7V 5% 0.4W	PHILIPS	BZX79C4V7	26.524
D18-4	DIODE SWITCH	BA243	TEK	BA243	25.386
D19-4	DIODE	BAW62 HIGH SPEED	PHILIPS	BAW62-143	25.350
D20-4	DIODE	BAW62 HIGH SPEED	PHILIPS	BAW62-143	25.350
D21-4	DIODE ZENER	7.5V 5% 0.4W	PHILIPS	BZX79C7V5	26.539
FL1-4	CRYSTAL FILTER	Fc=10.72995MHz	NDK	SP.SPEC: C1072D	40.030
FL2-4	CRYSTAL FILTER	Fc=70MHz>BILIT	NDK	70N20B D360B 1SET=2PCS	40.031
FL3-4	CRYSTAL FILTER	Fc=70MHz>BILIT	NDK	70N20B D360B 1SET=2PCS	40.031
J1-4	SOCKET COAX	HORISONTAL FOR PCB MOUNT.	TAIKO	TMP-J01X-A2	78.517

POSITION	DESCRIPTION		MANUFACTOR	TYPE	S.P. NUMBER
J2-4	SOCKET COAX	HORISONTAL FOR PCB MOUNT.	TAIKO	TMP-J01X-A2	78.517
J3-4	SOCKET COAX	HORISONTAL FOR PCB MOUNT.	TAIKO	TMP-J01X-A2	78.517
J4-4	SOCKET COAX	HORISONTAL FOR PCB MOUNT.	TAIKO	TMP-J01X-A2	78.517
L1-4	CHOKE FIXED	82uH 5%	NEOSID	00 6122 11 AMMO PACK	20.168
L2-4	CHOKE FIXED	82uH 5%	NEOSID	00 6122 11 AMMO PACK	20.168
L3-4	CHOKE FIXED	82uH 5%	NEOSID	00 6122 11 AMMO PACK	20.168
L4-4	CHOKE FIXED	82uH 5%	NEOSID	00 6122 11 AMMO PACK	20.168
L5-4	COIL	ADJUSTABLE Fc=10.7MHz	MITSUMI	L-2M7-D3/DM-8097	38.435
L6-4	CHOKE FIXED	1uSH 10%	FASTRON	MICC-1R5K-02	20.349
L7-4	COIL	ADJUSTABLE Fc=10.7MHz	MITSUMI	L-2M7-D3/DM-8098	38.436
L8-4	COIL	ADJUSTABLE Fc=10.7MHz	MITSUMI	L-2M7-D3/DM-8096	38.434
L9-4	COIL	ADJUSTABLE Fc=10.7MHz	MITSUMI	L-2M7-D3/DM-8098	38.436
L10-4	COIL	ADJUSTABLE Fc=70MHz	MITSUMI	L-2M7-D3/DM-8099	38.437
L11-4	COIL RF	586nH ADJUSTABLE	MITSUMI	L-2M7-D3/DM-8100	38.439
L12-4	COIL RF	586nH ADJUSTABLE	MITSUMI	L-2M7-D3/DM-8100	38.439
L13-4	CHOKE FIXED	10uH 5%	NEOSID	00 6122 00 AMMO PACK	20.118
P1-4	PLUG	2x10 POLES	3M	3592-6002	78.250
Q1-4	TRANSISTOR JFET	T1S88A3 10-92	MOTORPLA	TM 00 044-3	29.737
Q2-4	TRANSISTOR AF	BC548B NPN 10-92	PHILIPS	BC548B	28.076
Q3-4	TRANSISTOR AF	BC548B NPN 10-92	PHILIPS	BC548B	28.076
Q4-4	TRANSISTOR AF	BC548B NPN 10-92	PHILIPS	BC548B	28.076
Q5-4	TRANSISTOR RF	BF494 PNP 10-92	PHILIPS	BF494	28.201
Q6-4	TRANSISTOR RF	BF494 PNP 10-92	PHILIPS	BF494	28.201
Q7-4	TRANSISTOR AF	BC558 PNP 10-92	PHILIPS	BC558 (-A/-B/-C)	28.095
Q8-4	TRANSISTOR RF	BF494 PNP 10-92	PHILIPS	BF494	28.201
Q9-4	TRANSISTOR RF	BF494 PNP 10-92	PHILIPS	BF494	28.201
Q10-4	TRANSISTOR RF	BF494 PNP 10-92	PHILIPS	BF494	28.201
Q11-4	TRANSISTOR RF	BF494 PNP 10-92	PHILIPS	BF494	28.201
Q12-4	TRANSISTOR RF	BF494 PNP 10-92	PHILIPS	BF494	28.201
Q13-4	TRANSISTOR RF	BFW17A PNP 10-39	PHILIPS	BFW17A	29.151
Q14-4	TRANSISTOR AF	BC548B NPN 10-92	PHILIPS	BC548B	28.076
Q15-4	TRANSISTOR AF	BC548B NPN 10-92	PHILIPS	BC548B	28.076
Q16-4	TRANSISTOR AF	BC548B NPN 10-92	PHILIPS	BC548B	28.076
Q17-4	TRANSISTOR RF	BFW17A PNP 10-39	PHILIPS	BFW17A	29.151
Q18-4	TRANSISTOR RF	BF494 PNP 10-92	PHILIPS	BF494	28.201
Q19-4	TRANSISTOR RF	BFW17A PNP 10-39	PHILIPS	BFW17A	29.151
Q20-4	TRANSISTOR AF	BC548B NPN 10-92	PHILIPS	BC548B	28.076
Q21-4	TRANSISTOR AF	BC548B NPN 10-92	PHILIPS	BC548B	28.076
Q22-4	TRANSISTOR AF	BC548B NPN 10-92	PHILIPS	BC548B	28.076

POSITION	DESCRIPTION		MANUFACTURER	TYPE	S.P. NUMBER
Q23-4	TRANSISTOR AF	BC548B NPN TO-92	PHILIPS	BC548B	28.076
Q24-4	TRANSISTOR KF	BFW17A PNP TO-39	PHILIPS	BFW17A	29.151
Q25-4	TRANSISTOR MOSFET	N-CHANNEL ENHANCEMENT	SILICONIX	SD210DE	29.719
R1-4	RESISTOR MF	56 OHM 5% 0.33W	PHILIPS	2322 180 73569	02.442
R2-4	RESISTOR MF	1k2 OHM 5% 0.33W	PHILIPS	2322 180 73122	02.474
R4-4	RESISTOR ARRAY	4x10k OHM 5% 1/8W	PANASONIC	EXBF8V1036 (4X10K)	08.615
R6-4	RESISTOR MF	560 OHM 5% 0.33W	PHILIPS	2322 180 73561	02.466
R7-4	RESISTOR MF	6k8 OHM 5% 0.33W	PHILIPS	2322 180 73682	02.492
R8-4	RESISTOR MF	1k2 OHM 5% 0.33W	PHILIPS	2322 180 73122	02.474
R9-4	RESISTOR MF	270 OHM 5% 0.33W	PHILIPS	2322 180 73271	02.458
R11-4	RESISTOR MF	220 OHM 5% 0.4W	PHILIPS	2322 181 53221	01.183
R12-4	RESISTOR MF	18k OHM 5% 0.33W	PHILIPS	2322 180 73183	02.502
R13-4	RESISTOR ARRAY	4x10k OHM 5% 1/8W	PANASONIC	EXBF8V1036 (4X10K)	08.615
R16-4	RESISTOR MF	2k7 OHM 5% 0.33W	PHILIPS	2322 180 73272	02.482
R18-4	RESISTOR MF	2k0 OHM 5% 0.33W	PHILIPS	2322 180 73202	02.479
R19-4	RESISTOR MF	7k5 OHM 5% 0.33W	PHILIPS	2322 180 73752	02.493
R20-4	RESISTOR MF	5k6 OHM 5% 0.33W	PHILIPS	2322 180 73562	02.490
R21-4	RESISTOR MF	10k OHM 5% 0.33W	PHILIPS	2322 180 73103	02.496
R22-4	RESISTOR MF	15k OHM 5% 0.33W	PHILIPS	2322 180 73153	02.500
R23-4	RESISTOR MF	470 OHM 5% 0.33W	PHILIPS	2322 180 73471	02.464
R24-4	RESISTOR MF	30k OHM 5% 0.33W	PHILIPS	2322 180 73303	02.507
R25-4	RESISTOR MF	560k OHM 5% 0.33W	PHILIPS	2322 180 73564	02.538
R26-4	RESISTOR MF	120k OHM 5% 0.33W	PHILIPS	2322 180 73124	02.522
R27-4	RESISTOR MF	47k OHM 5% 0.33W	PHILIPS	2322 180 73473	02.512
R28-4	RESISTOR MF	33k OHM 5% 0.33W	PHILIPS	2322 180 73333	02.508
R29-4	RESISTOR MF	2k2 OHM 5% 0.33W	PHILIPS	2322 180 73222	02.480
R30-4	RESISTOR MF	560k OHM 5% 0.33W	PHILIPS	2322 180 73564	02.538
R31-4	RESISTOR MF	10k OHM 5% 0.33W	PHILIPS	2322 180 73103	02.496
R32-4	RESISTOR MF	100k OHM 5% 0.33W	PHILIPS	2322 180 73104	02.520
R33-4	RESISTOR MF	1k5 OHM 5% 0.33W	PHILIPS	2322 180 73152	02.476
R34-4	RESISTOR MF	5k6 OHM 5% 0.33W	PHILIPS	2322 180 73562	02.490
R35-4	PRESET CERMET	10k OHM 10% 0.5W	BOURNS	3386P-1-103	07.889
R36-4	RESISTOR MF	4k7 OHM 5% 0.33W	PHILIPS	2322 180 73472	02.488
R37-4	RESISTOR MF	10k OHM 5% 0.33W	PHILIPS	2322 180 73103	02.496
R38-4	RESISTOR MF	10k OHM 5% 0.33W	PHILIPS	2322 180 73103	02.496
R39-4	RESISTOR MF	10k OHM 5% 0.33W	PHILIPS	2322 180 73103	02.496
R40-4	RESISTOR MF	10k OHM 5% 0.33W	PHILIPS	2322 180 73103	02.496
R41-4	RESISTOR MF	12k OHM 5% 0.33W	PHILIPS	2322 180 73123	02.498
R42-4	RESISTOR MF	10k OHM 5% 0.33W	PHILIPS	2322 180 73103	02.496
R43-4	RESISTOR MF	10k OHM 5% 0.33W	PHILIPS	2322 180 73103	02.496
R44-4	RESISTOR MF	1k0 OHM 5% 0.33W	PHILIPS	2322 180 73102	02.472
R45-4	RESISTOR MF	330 OHM 5% 0.33W	PHILIPS	2322 180 73331	02.460
R46-4	RESISTOR MF	330 OHM 5% 0.33W	PHILIPS	2322 180 73331	02.460
R47-4	RESISTOR MF	10k OHM 5% 0.33W	PHILIPS	2322 180 73103	02.496

POSITION	DESCRIPTION		MANUFACTURER	TYPE	S.P. NUMBER
R48-4	RESISTOR MF	2k2 OHM 5% 0.33W	PHILIPS	2322 180 73222	02.480
R49-4	RESISTOR MF	1k8 OHM 5% 0.33W	PHILIPS	2322 180 73182	02.478
R50-4	RESISTOR MF	820 OHM 5% 0.33W	PHILIPS	2322 180 73821	02.470
R51-4	RESISTOR MF	56 OHM 5% 0.33W	PHILIPS	2322 180 73569	02.442
R52-4	RESISTOR MF	1k5 OHM 5% 0.33W	PHILIPS	2322 180 73152	02.476
R53-4	RESISTOR MF	1k5 OHM 5% 0.33W	PHILIPS	2322 180 73152	02.476
R54-4	RESISTOR MF	12k OHM 5% 0.33W	PHILIPS	2322 180 73123	02.498
R55-4	RESISTOR MF	100 OHM 5% 0.33W	PHILIPS	2322 180 73101	02.448
R56-4	RESISTOR MF	1k8 OHM 5% 0.33W	PHILIPS	2322 180 73182	02.478
R57-4	PRESET CERMET	100k OHM 10% 0.5W	BOURNS	3386P-1-104	07.893
R58-4	RESISTOR MF	220k OHM 5% 0.33W	PHILIPS	2322 180 73224	02.528
R59-4	RESISTOR MF	47k OHM 5% 0.33W	PHILIPS	2322 180 73473	02.512
R60-4	RESISTOR MF	47k OHM 5% 0.33W	PHILIPS	2322 180 73473	02.512
R61-4	RESISTOR MF	560 OHM 5% 0.33W	PHILIPS	2322 180 73561	02.466
R62-4	RESISTOR MF	680 OHM 5% 0.33W	PHILIPS	2322 180 73681	02.468
R63-4	RESISTOR MF	120 OHM 5% 0.33W	PHILIPS	2322 180 73121	02.450
R64-4	RESISTOR MF	47 OHM 5% 0.33W	PHILIPS	2322 180 73479	02.440
R65-4	RESISTOR MF	330 OHM 5% 0.33W	PHILIPS	2322 180 73331	02.460
R66-4	RESISTOR MF	1k2 OHM 5% 0.33W	PHILIPS	2322 180 73122	02.474
R67-4	RESISTOR MF	330 OHM 5% 0.33W	PHILIPS	2322 180 73331	02.460
R68-4	RESISTOR MF	3k9 OHM 5% 0.33W	PHILIPS	2322 180 73392	02.486
R69-4	RESISTOR MF	1k0 OHM 5% 0.33W	PHILIPS	2322 180 73102	02.472
R70-4	RESISTOR MF	210 OHM 5% 0.33W	PHILIPS	2322 180 73211	02.471
R71-4	RESISTOR MF	15k OHM 5% 0.33W	PHILIPS	2322 180 73153	02.500
R72-4	RESISTOR MF	1k0 OHM 5% 0.33W	PHILIPS	2322 180 73102	02.472
R73-4	RESISTOR MF	220 OHM 5% 0.33W	PHILIPS	2322 180 73221	02.456
R74-4	RESISTOR MF	10k OHM 5% 0.33W	PHILIPS	2322 180 73103	02.496
R75-4	RESISTOR MF	3k9 OHM 5% 0.33W	PHILIPS	2322 180 73392	02.486
R76-4	RESISTOR MF	680 OHM 5% 0.33W	PHILIPS	2322 180 73681	02.468
R77-4	RESISTOR MF	33 OHM 5% 0.33W	PHILIPS	2322 180 73339	02.436
R78-4	RESISTOR MF	120 OHM 5% 0.33W	PHILIPS	2322 180 73121	02.450
R79-4	RESISTOR MF	3k9 OHM 5% 0.33W	PHILIPS	2322 180 73392	02.486
R80-4	RESISTOR MF	3k9 OHM 5% 0.33W	PHILIPS	2322 180 73392	02.486
R81-4	RESISTOR MF	1k0 OHM 5% 0.33W	PHILIPS	2322 180 73102	02.472
R82-4	RESISTOR MF	5k6 OHM 5% 0.33W	PHILIPS	2322 180 73562	02.490
R83-4	RESISTOR MF	5k6 OHM 5% 0.33W	PHILIPS	2322 180 73562	02.490
R84-4	RESISTOR MF	100 OHM 5% 0.33W	PHILIPS	2322 180 73101	02.448
R85-4	RESISTOR MF	180 OHM 5% 0.33W	PHILIPS	2322 180 73181	02.454
R86-4	RESISTOR MF	1k8 OHM 5% 0.33W	PHILIPS	2322 180 73182	02.478
R87-4	PRESET CERMET	200 OHM 10% 0.5W	BOURNS	3386P-1-201	07.884
R88-4	RESISTOR MF	47 OHM 5% 0.33W	PHILIPS	2322 180 73479	02.440
R89-4	RESISTOR MF	120 OHM 5% 0.33W	PHILIPS	2322 180 73121	02.450
R90-4	RESISTOR MF	470 OHM 5% 0.33W	PHILIPS	2322 180 73471	02.464
R91-4	RESISTOR MF	1k5 OHM 5% 0.33W	PHILIPS	2322 180 73152	02.476

POSITION	DESCRIPTION		MANUFACTOR	TYPE	S.P. NUMBER
R92-4	PRESET CERMET	2k0 OHM 5% 0.5W	BOURNS	3386P-1-202-11	07.887
R93-4	RESISTOR MF	2k7 OHM 5% 0.33W	PHILIPS	2322 180 73272	02.482
R94-4	RESISTOR MF	3k9 OHM 5% 0.33W	PHILIPS	2322 180 73392	02.486
R95-4	RESISTOR MF	270 OHM 5% 0.33W	PHILIPS	2322 180 73271	02.458
R96-4	RESISTOR MF	62 OHM 5% 0.33W	PHILIPS	2322 180 73629	02.443
R97-4	RESISTOR MF	3k9 OHM 5% 0.33W	PHILIPS	2322 180 73392	02.486
R98-4	RESISTOR MF	5k6 OHM 5% 0.33W	PHILIPS	2322 180 73562	02.490
R99-4	RESISTOR MF	10k OHM 5% 0.33W	PHILIPS	2322 180 73103	02.496
R100-4	RESISTOR MF	100 OHM 5% 0.33W	PHILIPS	2322 180 73101	02.448
R101-4	RESISTOR MF	1k8 OHM 5% 0.33W	PHILIPS	2322 180 73182	02.478
R102-4	RESISTOR MF	47 OHM 5% 0.33W	PHILIPS	2322 180 73479	02.440
R103-4	RESISTOR MF	22 OHM 5% 0.33W	PHILIPS	2322 180 73229	02.432
R104-4	RESISTOR MF	100 OHM 5% 0.33W	PHILIPS	2322 180 73101	02.448
R105-4	RESISTOR MF	3k3 OHM 5% 0.33W	PHILIPS	2322 180 73332	02.484
R106-4	RESISTOR MF	2k7 OHM 5% 0.33W	PHILIPS	2322 180 73272	02.482
R107-4	RESISTOR MF	390 OHM 5% 0.33W	PHILIPS	2322 180 73391	02.462
R108-4	RESISTOR MF	100 OHM 5% 0.33W	PHILIPS	2322 180 73101	02.448
R109-4	RESISTOR MF	47 OHM 5% 0.33W	PHILIPS	2322 180 73479	02.440
R110-4	RESISTOR MF	330 OHM 5% 0.4W	PHILIPS	2322 181 53331	01.187
R111-4	RESISTOR MF	3k3 OHM 5% 0.33W	PHILIPS	2322 180 73332	02.484
R112-4	RESISTOR MF	18k OHM 5% 0.33W	PHILIPS	2322 180 73183	02.502
R113-4	RESISTOR MF	18k OHM 5% 0.33W	PHILIPS	2322 180 73183	02.502
R114-4	RESISTOR MF	8k2 OHM 5% 0.33W	PHILIPS	2322 180 73822	02.494
R115-4	RESISTOR MF	560 OHM 5% 0.33W	PHILIPS	2322 180 73561	02.466
R116-4	RESISTOR MF	1k5 OHM 5% 0.33W	PHILIPS	2322 180 73152	02.476
R117-4	RESISTOR MF	47 OHM 5% 0.33W	PHILIPS	2322 180 73479	02.440
R118-4	RESISTOR MF	270 OHM 5% 0.33W	PHILIPS	2322 180 73271	02.458
R119-4	RESISTOR MF	4k7 OHM 5% 0.33W	PHILIPS	2322 180 73472	02.488
R120-4	PRESET CERMET	200 OHM 10% 0.5W	BOURNS	3386P-1-201	07.884
R121-4	RESISTOR MF	3k3 OHM 5% 0.33W	PHILIPS	2322 180 73332	02.484
R122-4	RESISTOR MF	1k5 OHM 5% 0.33W	PHILIPS	2322 180 73152	02.476
R123-4	RESISTOR MF	330 OHM 5% 0.33W	PHILIPS	2322 180 73331	02.460
R124-4	RESISTOR MF	270 OHM 5% 0.33W	PHILIPS	2322 180 73271	02.458
R125-4	RESISTOR MF	27 OHM 5% 0.33W	PHILIPS	2322 180 73279	02.434
R126-4	RESISTOR MF	15k OHM 5% 0.33W	PHILIPS	2322 180 73153	02.500
R127-4	RESISTOR MF	150 OHM 5% 0.33W	PHILIPS	2322 180 73151	02.452
R128-4	RESISTOR MF	8k2 OHM 5% 0.33W	PHILIPS	2322 180 73822	02.494
R129-4	RESISTOR MF	5k6 OHM 5% 0.33W	PHILIPS	2322 180 73562	02.490
R130-4	RESISTOR MF	576 OHM 1% 0.25W	PHILIPS	2322 157 15761	02.217
R131-4	RESISTOR MF	1k5 OHM 5% 0.33W	PHILIPS	2322 180 73152	02.476
R132-4	RESISTOR MF	360 OHM 5% 0.33W	PHILIPS	2322 180 73361	02.461
R133-4	RESISTOR MF	680 OHM 5% 0.33W	PHILIPS	2322 180 73681	02.468
R134-4	RESISTOR MF	47 OHM 5% 0.33W	PHILIPS	2322 180 73479	02.440
R135-4	RESISTOR MF	470 OHM 5% 0.33W	PHILIPS	2322 180 73471	02.464

POSITION	DESCRIPTION		MANUFACTOR	TYPE	S.P. NUMBER
R136-4	RESISTOR MF	1k2 OHM 5% 0.33W	PHILIPS	2322 180 73122	02.474
R137-4	RESISTOR MF	1k8 OHM 5% 0.33W	PHILIPS	2322 180 73182	02.478
R138-4	RESISTOR MF	820 OHM 5% 0.33W	PHILIPS	2322 180 73821	02.470
R139-4	RESISTOR MF	6k8 OHM 5% 0.33W	PHILIPS	2322 180 73682	02.492
R140-4	RESISTOR MF	357 OHM 1% 0.25W	PHILIPS	2322 157 13571	02.215
R141-4	RESISTOR MF	8k2 OHM 5% 0.33W	PHILIPS	2322 180 73822	02.494
R142-4	RESISTOR MF	180 OHM 5% 0.4W	PHILIPS	2322 181 53181	01.181
R143-4	RESISTOR MF	8k2 OHM 5% 0.33W	PHILIPS	2322 180 73822	02.494
R144-4	RESISTOR MF	8k2 OHM 5% 0.33W	PHILIPS	2322 180 73822	02.494
R145-4	RESISTOR MF	215 OHM 1% 0.25W	PHILIPS	2322 157 12151	02.212
R146-4	RESISTOR MF	8k2 OHM 5% 0.33W	PHILIPS	2322 180 73822	02.494
R147-4	RESISTOR MF	120 OHM 5% 0.33W	PHILIPS	2322 180 73121	02.450
R148-4	RESISTOR MF	110 OHM 1% 0.25W	PHILIPS	2322 157 11101	02.211
R149-4	RESISTOR MF	15k OHM 5% 0.33W	PHILIPS	2322 180 73153	02.500
R150-4	RESISTOR MF	470 OHM 5% 0.4W	PHILIPS	2322 181 53471	01.191
R151-4	RESISTOR MF	1k78 OHM 1% 0.25W	PHILIPS	2322 157 11782	02.205
R152-4	RESISTOR MF	6k8 OHM 5% 0.33W	PHILIPS	2322 180 73682	02.492
R153-4	RESISTOR MF	1k00 OHM 1% 0.25W	PHILIPS	2322 157 11002	02.200
R154-4	RESISTOR MF	120 OHM 5% 0.33W	PHILIPS	2322 180 73121	02.450
R155-4	RESISTOR MF	8k2 OHM 5% 0.33W	PHILIPS	2322 180 73822	02.494
R156-4	RESISTOR MF	220 OHM 5% 0.4W	PHILIPS	2322 181 53221	01.183
R157-4	RESISTOR MF	1k8 OHM 5% 0.33W	PHILIPS	2322 180 73182	02.478
R158-4	RESISTOR MF	120 OHM 5% 0.33W	PHILIPS	2322 180 73121	02.450
R159-4	PRESET CERMET	200 OHM 10% 0.5W	BOURNS	3386P-1-201	07.884
R160-4	RESISTOR MF	2k7 OHM 5% 0.33W	PHILIPS	2322 180 73272	02.482
R161-4	RESISTOR MF	270 OHM 5% 0.33W	PHILIPS	2322 180 73271	02.458
R162-4	RESISTOR MF	680 OHM 5% 0.33W	PHILIPS	2322 180 73681	02.468
R163-4	RESISTOR MF	150 OHM 5% 0.33W	PHILIPS	2322 180 73151	02.452
R164-4	RESISTOR MF	39 OHM 5% 0.33W	PHILIPS	2322 180 73399	02.438
R165-4	RESISTOR MF	5.6 OHM 5% 0.33W	PHILIPS	2322 180 73568	02.418
R166-4	RESISTOR MF	120 OHM 5% 0.33W	PHILIPS	2322 180 73121	02.450
R167-4	RESISTOR MF	120 OHM 5% 0.33W	PHILIPS	2322 180 73121	02.450
R168-4	RESISTOR MF	56 OHM 5% 0.33W	PHILIPS	2322 180 73569	02.442
R169-4	RESISTOR MF	47 OHM 5% 0.33W	PHILIPS	2322 180 73479	02.440
R170-4	RESISTOR MF	8k2 OHM 5% 0.33W	PHILIPS	2322 180 73822	02.494
R171-4	RESISTOR MF	120 OHM 5% 0.33W	PHILIPS	2322 180 73121	02.450
R172-4	RESISTOR MF	3k9 OHM 5% 0.33W	PHILIPS	2322 180 73392	02.486
R173-4	RESISTOR MF	511 OHM 1% 0.25W	PHILIPS	2322 157 15111	02.245
R174-4	RESISTOR MF	2k2 OHM 5% 0.33W	PHILIPS	2322 180 73222	02.480
R175-4	RESISTOR MF	261 OHM 1% 0.25W	PHILIPS	2322 157 12611	02.243
R176-4	RESISTOR MF	120 OHM 5% 0.33W	PHILIPS	2322 180 73121	02.450
R177-4	RESISTOR MF	8k2 OHM 5% 0.33W	PHILIPS	2322 180 73822	02.494
R178-4	RESISTOR MF	33 OHM 5% 0.33W	PHILIPS	2322 180 73339	02.436
R179-4	RESISTOR MF	68 OHM 5% 0.33W	PHILIPS	2322 180 73689	02.444

RE2100 35/91

POSITION	DESCRIPTION		MANUFACTURER	TYPE	S.P. NUMBER
R180-4	RESISTOR NTC	150 OHM 10% 0.5W	PHILIPS	2322 642 62151	07.265
R181-4	RESISTOR MF	62 OHM 5% 0.33W	PHILIPS	2322 180 73629	02.443
R182-4	RESISTOR NTC	10 OHM 10% 0.5W	PHILIPS	2322 642 62109	07.255
R183-4	RESISTOR MF	22 OHM 5% 0.4W	PHILIPS	2322 181 53229	01.158
R184-4	RESISTOR MF	180 OHM 5% 0.4W	PHILIPS	2322 181 53181	01.181
R185-4	RESISTOR MF	820 OHM 5% 0.4W	PHILIPS	2322 181 53821	01.197
R186-4	RESISTOR PMF	120 OHM 5% 2W	PHILIPS	2322 191 31201	04.178
R187-4	RESISTOR MF	1k5 OHM 5% 0.33W	PHILIPS	2322 180 73152	02.476
R188-4	RESISTOR MF	5k6 OHM 5% 0.33W	PHILIPS	2322 180 73562	02.490
R189-4	RESISTOR MF	2k2 OHM 5% 0.33W	PHILIPS	2322 180 73222	02.480
R190-4	PRESET CERMET	2k0 OHM 5% 0.5W	BOURNS	3386P-1-202-11	07.887
R191-4	RESISTOR MF	680 OHM 5% 0.33W	PHILIPS	2322 180 73681	02.468
R192-4	RESISTOR NTC	4k7 OHMS 10% .75W	PHILIPS	2322 642 62472	07.280
R193-4	RESISTOR MF	1k5 OHM 5% 0.33W	PHILIPS	2322 180 73152	02.476
R196-4	RESISTOR MF	62 OHM 5% 0.33W	PHILIPS	2322 180 73629	02.443
TR1-4	TRANSFORMER	207H ADJUSTABLE	TOKO	F292MNS-3342BQE	38.431
TR2-4	TRANSFORMER	ADJUSTABLE F <sub>r</sub> =10.7MHZ	MITSUMI	L-2H7-D3/DH-8095	38.433
TR3-4	TRANSFORMER	TL492	S.P.RADIO	6-0-25811	400492
TR4-4	TRANSFORMER	TL492	S.P.RADIO	6-0-25811	400492
U1-4	INTEGRATED CIRCUIT	QUAD ANALOG SWITCH	MOTOROLA	MC14066BCP	33.232
U2-4	INTEGRATED CIRCUIT	OP-AMP, OPEN COLLECTOR OUT	SIEMENS	Q67000-A524 (TAA765A)	31.300
U3-4	QUAD OP. AMP.	324	TEXAS	LM324N	31.065
U4-4	INTEGRATED CIRCUIT	DUAL OPERATIONAL AMP.	TEXAS	MC1458P	31.215
U5-4	INTEGRATED CIRCUIT	DUAL OPERATIONAL AMP.	TEXAS	MC1458P	31.215
U6-4	INTEGRATED CIRCUIT	BALANCED MODULATOR	PHILIPS	MC1496N	31.221
U7-4	INTEGRATED CIRCUIT	8 BIT SHIFT REG. SERIAL IO	NATIONAL	MM74HC595N	34.502
U8-4	INTEGRATED CIRCUIT	QUADRUPLE LINE DRIVER	TEXAS	SN75188N	34.304
U9-4	INTEGRATED CIRCUIT	8 BIT SHIFT REG. SERIAL IO	NATIONAL	MM74HC595N	34.502
U10-4	DIODE MIXER	DOUBLE BALANCED +7dBm	TDK	CB312M1B	27.785
U11-4	DIODE MIXER	+17dBm	TOK	CB 302 M2B	27.782

POSITION	DESCRIPTION		MANUFACTOR	TYPE	S.P. NUMBER
	PROCESSOR MODULE 5	RF2100	ESPERA	5-0-25635K	625635
	JUMPER	2 POLE	SAMTEC*	M5L-260-6	78.325
C1-5	CAPACITOR CERAMIC	10nF -20/+80% CL2 50VDC	KCK	RT-HE70 SK YF 103 Z AMMO PACK	15.170
C2-5	CAPACITOR CERAMIC	10nF -20/+80% CL2 50VDC	KCK	RT-HE70 SK YF 103 Z AMMO PACK	15.170
C3-5	CAPACITOR CERAMIC	1n0F 10% CL2 500VDC	KCK	RT-HM60 SK YB 102 K AMMO PACK	15.160
C4-5	CAPACITOR CERAMIC	10nF -20/+80% CL2 50VDC	KCK	RT-HE70 SK YF 103 Z AMMO PACK	15.170
C5-5	CAPACITOR CERAMIC	10nF -20/+80% CL2 50VDC	KCK	RT-HE70 SK YF 103 Z AMMO PACK	15.170
C6-5	CAPACITOR CERAMIC	10nF -20/+80% CL2 50VDC	KCK	RT-HE70 SK YF 103 Z AMMO PACK	15.170
C7-5	CAPACITOR CERAMIC	22pF 5% NPO 500VDC	KCK	RT-HM60 SK CH 220 J AMMO PACK	15.080
C8-5	CAPACITOR CERAMIC	22pF 5% NPO 500VDC	KCK	RT-HM60 SK CH 220 J AMMO PACK	15.080
C10-5	CAPACITOR ELECTROLYTIC	220uF -20/+50% 16VDC	ELNA	RJ2-16-V-221-M-T2	14.640
C11-5	CAPACITOR ELECTROLYTIC	1000uF -10/+50% 16VDC	ERO	EB 00 HD 410 D B5	14.578
C13-5	CAPACITOR MKT	0.1uF 10% 63VDC	PHILIPS	2222 370 78104	11.136
C14-5	CAPACITOR ELECTROLYTIC	220uF -20/+50% 16VDC	ELNA	RJ2-16-V-221-M-T2	14.640
C15-5	CAPACITOR MKT	0.1uF 10% 63VDC	PHILIPS	2222 370 78104	11.136
C16-5	CAPACITOR MKT	0.1uF 10% 63VDC	PHILIPS	2222 370 78104	11.136
C17-5	CAPACITOR CERAMIC	10nF -20/+80% CL2 50VDC	KCK	RT-HE70 SK YF 103 Z AMMO PACK	15.170
C18-5	CAPACITOR MKT	0.1uF 10% 63VDC	PHILIPS	2222 370 78104	11.136
C20-5	CAPACITOR CERAMIC	1n0F 10% CL2 500VDC	KCK	RT-HM60 SK YB 102 K AMMO PACK	15.160
C21-5	CAPACITOR MKT	0.1uF 10% 63VDC	PHILIPS	2222 370 78104	11.136
C23-5	CAPACITOR CERAMIC	10nF -20/+80% CL2 50VDC	KCK	RT-HE70 SK YF 103 Z AMMO PACK	15.170
C25-5	CAPACITOR CERAMIC	10nF -20/+80% CL2 50VDC	KCK	RT-HE70 SK YF 103 Z AMMO PACK	15.170
C26-5	CAPACITOR CERAMIC	10nF -20/+80% CL2 50VDC	KCK	RT-HE70 SK YF 103 Z AMMO PACK	15.170
C27-5	CAPACITOR CERAMIC	10nF -20/+80% CL2 50VDC	KCK	RT-HE70 SK YF 103 Z AMMO PACK	15.170
C28-5	CAPACITOR CERAMIC	10nF -20/+80% CL2 50VDC	KCK	RT-HE70 SK YF 103 Z AMMO PACK	15.170
C29-5	CAPACITOR CERAMIC	10nF -20/+80% CL2 50VDC	KCK	RT-HE70 SK YF 103 Z AMMO PACK	15.170
C30-5	CAPACITOR CERAMIC	1n0F 10% CL2 500VDC	KCK	RT-HM60 SK YB 102 K AMMO PACK	15.160
C31-5	CAPACITOR CERAMIC	1n0F 10% CL2 500VDC	KCK	RT-HM60 SK YB 102 K AMMO PACK	15.160
C32-5	CAPACITOR CERAMIC	1n0F 10% CL2 500VDC	KCK	RT-HM60 SK YB 102 K AMMO PACK	15.160
C33-5	CAPACITOR CERAMIC	47pF 5% N150 50VDC	KCK	RT-HE60-SK PH 470 J AMMO PACK	15.100
C34-5	CAPACITOR CERAMIC	470pF 10% 500VDC	KCK	RT-HM60 SK YB 471 K AMMO PACK	16.095
C35-5	CAPACITOR CERAMIC	1n0F 10% CL2 500VDC	KCK	RT-HM60 SK YB 102 K AMMO PACK	15.160
C36-5	CAPACITOR CERAMIC	1n0F 10% CL2 500VDC	KCK	RT-HM60 SK YB 102 K AMMO PACK	15.160
C37-5	CAPACITOR CERAMIC	1n0F 10% CL2 500VDC	KCK	RT-HM60 SK YB 102 K AMMO PACK	15.160
C38-5	CAPACITOR CERAMIC	1n0F 10% CL2 500VDC	KCK	RT-HM60 SK YB 102 K AMMO PACK	15.160
C39-5	CAPACITOR MKT	1uF 10% 63VDC	PHILIPS	2222 370 78105	11.137
C40-5	CAPACITOR MKT	1uF 10% 63VDC	PHILIPS	2222 370 78105	11.137
C41-5	CAPACITOR CERAMIC	10nF -20/+80% CL2 50VDC	KCK	RT-HE70 SK YF 103 Z AMMO PACK	15.170
C42-5	CAPACITOR CERAMIC	1n0F 10% CL2 500VDC	KCK	RT-HM60 SK YB 102 K AMMO PACK	15.160
C43-5	CAPACITOR CERAMIC	10nF -20/+80% CL2 50VDC	KCK	RT-HE70 SK YF 103 Z AMMO PACK	15.170
C44-5	CAPACITOR ELECTROLYTIC	220uF -20/+50% 16VDC	ELNA	RJ2-16-V-221-M-T2	14.640
C45-5	CAPACITOR ELECTROLYTIC	220uF -20/+50% 16VDC	ELNA	RJ2-16-V-221-M-T2	14.640
C46-5	CAPACITOR ELECTROLYTIC	220uF -20/+50% 16VDC	ELNA	RJ2-16-V-221-M-T2	14.640
C47-5	CAPACITOR ELECTROLYTIC	100uF -10/+50% 25VDC	ERO	EKM 00 CC 310 E 65	14.610
C48-5	CAPACITOR ELECTROLYTIC	100uF -10/+50% 25VDC	ERO	EKM 00 CC 310 E 65	14.610
C49-5	CAPACITOR ELECTROLYTIC	220uF -20/+50% 16VDC	ELNA	RJ2-16-V-221-M-T2	14.640
C50-5	CAPACITOR CERAMIC	10nF -20/+80% CL2 50VDC	KCK	RT-HE70 SK YF 103 Z AMMO PACK	15.170
C51-5	CAPACITOR CERAMIC	10nF -20/+80% CL2 50VDC	KCK	RT-HE70 SK YF 103 Z AMMO PACK	15.170
C52-5	CAPACITOR CERAMIC	10nF -20/+80% CL2 50VDC	KCK	RT-HE70 SK YF 103 Z AMMO PACK	15.170
C53-5	CAPACITOR CERAMIC	10nF -20/+80% CL2 50VDC	KCK	RT-HE70 SK YF 103 Z AMMO PACK	15.170
C54-5	CAPACITOR CERAMIC	470pF 10% 500VDC	KCK	RT-HM60 SK YB 471 K AMMO PACK	16.095
D2-5	DIODE RECTIFIER	1N4002 100V/1A	THOMSON	1N4002 (03/04/05/06/07)	25.100
D4-5	DIODE ZENER	5.1V 5% 0.4W	PHILIPS	BZX79C5V1	26.527

POSITION	DESCRIPTION		MANUFACTURER	TYPE	S.P. NUMBER
D5-5	DIODE ZENER	5.1V 5% 0.4W	PHILIPS	BZX79C5V1	26.527
D6-5	DIODE ZENER	5.1V 5% 0.4W	PHILIPS	BZX79C5V1	26.527
D9-5	DIODE ZENER	5.1V 5% 0.4W	PHILIPS	BZX79C5V1	26.527
D11-5	DIODE SCHOTTKY	BAT 43	THOMSON-CSF	BAT43	27.600
J1-5	SOCKET	2x7 POLES	AMP	1-215079-4	78.196
J2-5	SOCKET	2x7 POLES	AMP	1-215079-4	78.196
J3-5	SOCKET 25 POLES	SUB D RIGHT ANGLE	AMP	343707-2	78.169
J4-5	RECEPTACLE	BNC RIGHT ANGLE	ROSENBERGER	51K-201-400 A4	78.443
L1-5	CHOKE FIXED	180uH 5%	FASTRON	SMCC-181J-02	20.313
L2-5	CHOKE FIXED	220uH 5%	FASTRON	SMCC-221J-02	20.314
P1-5	PLUG	1/10" SIL SQ.PINS 3 POLES	EURO DIP	PH1-029/058-03-ZG075	78.323
P3-5	PLUG	1/10" SIL SQ.PINS 3 POLES	EURO DIP	PH1-029/058-03-ZG075	78.323
P4-5	PLUG	1/10" SIL SQ.PINS 2 POLES	EURODIP	PH1-029/058-2-ZG075	78.322
P5-5	PLUG	2x13 POLES	3M	3595-6002	78.248
P6-5	PLUG	2x5 POLES	3M	3654-6002	78.251
Q1-5	TRANSISTOR AF	BC548 NPN TO-92	PHILIPS	BC548 (-A/-B/-C)	28.070
Q2-5	TRANSISTOR AF	BC548 NPN TO-92	PHILIPS	BC548 (-A/-B/-C)	28.070
Q3-5	TRANSISTOR AF	BC558 PNP TO-92	PHILIPS	BC558 (-A/-B/-C)	28.095
Q4-5	TRANSISTOR AF	BC558 PNP TO-92	PHILIPS	BC558 (-A/-B/-C)	28.095
Q5-5	TRANSISTOR	BC640	PHILIPS	BC640	28.124
Q6-5	TRANSISTOR AF	NPN BC639 TO-92	PHILIPS	BC639	28.120
R1-5	RESISTOR MF	330 OHM 5% 0.33W	PHILIPS	2322 180 73331	02.460
R2-5	RESISTOR MF	2k2 OHM 5% 0.33W	PHILIPS	2322 180 73222	02.480
R3-5	RESISTOR MF	100k OHM 5% 0.33W	PHILIPS	2322 180 73104	02.520
R4-5	RESISTOR MF	56k OHM 5% 0.33W	PHILIPS	2322 180 73563	02.514
R5-5	RESISTOR MF	56k OHM 5% 0.33W	PHILIPS	2322 180 73563	02.514
R6-5	RESISTOR ARRAY	8x10k OHM 5% 1/8W	PANASONIC	EXB-F9E-103 J	08.630
R7-5	RESISTOR ARRAY	8x10k OHM 5% 1/8W	PANASONIC	EXB-F9E-103 J	08.630
R8-5	RESISTOR MF	10k OHM 5% 0.33W	PHILIPS	2322 180 73103	02.496
R9-5	RESISTOR MF	10k OHM 5% 0.33W	PHILIPS	2322 180 73103	02.496
R19-5	RESISTOR MF	6k8 OHM 5% 0.33W	PHILIPS	2322 180 73682	02.492
R20-5	RESISTOR MF	10k OHM 5% 0.33W	PHILIPS	2322 180 73103	02.496
R24-5	RESISTOR MF	12k OHM 5% 0.33W	PHILIPS	2322 180 73123	02.498
R25-5	RESISTOR MF	47k OHM 5% 0.33W	PHILIPS	2322 180 73473	02.512
R26-5	RESISTOR MF	1k0 OHM 5% 0.33W	PHILIPS	2322 180 73102	02.472
R28-5	RESISTOR MF	10k OHM 5% 0.33W	PHILIPS	2322 180 73103	02.496
R29-5	RESISTOR MF	12k OHM 5% 0.33W	PHILIPS	2322 180 73123	02.498
R30-5	RESISTOR MF	39k2 OHM 1% 0.25W	PHILIPS	2322 157 13923	02.239
R31-5	RESISTOR MF	120k OHM 5% 0.33W	PHILIPS	2322 180 73124	02.522
R32-5	RESISTOR MF	1k2 OHM 5% 0.33W	PHILIPS	2322 180 73122	02.474
R33-5	RESISTOR MF	3k0 OHM 5% 0.33W	PHILIPS	2322 180 73302	02.483
R34-5	RESISTOR MF	10k OHM 5% 0.33W	PHILIPS	2322 180 73103	02.496
R35-5	RESISTOR MF	12k OHM 5% 0.33W	PHILIPS	2322 180 73123	02.498
R36-5	RESISTOR MF	12k OHM 5% 0.33W	PHILIPS	2322 180 73123	02.498

POSITION	DESCRIPTION		MANUFACTURER	TYPE	S.P. NUMBER
R37-5	RESISTOR MF	47k OHM 5% 0.33W	PHILIPS	2322 180 73473	02.512
R39-5	RESISTOR MF	220 OHM 5% 0.33W	PHILIPS	2322 180 73221	02.456
R40-5	RESISTOR MF	5.6 OHM 5% 0.33W	PHILIPS	2322 180 73568	02.418
R41-5	RESISTOR MF	5.6 OHM 5% 0.33W	PHILIPS	2322 180 73568	02.418
R42-5	RESISTOR MF	18 OHM 5% 0.33W	PHILIPS	2322 180 73189	02.430
R43-5	RESISTOR MF	1k0 OHM 5% 0.33W	PHILIPS	2322 180 73102	02.472
R44-5	RESISTOR MF	1k0 OHM 5% 0.33W	PHILIPS	2322 180 73102	02.472
R45-5	RESISTOR MF	10k OHM 5% 0.33W	PHILIPS	2322 180 73103	02.496
R46-5	RESISTOR ARRAY	8x10k OHM 5% 1/8W	PANASONIC	EXB-F9E-103 J	08.630
R47-5	RESISTOR MF	51.1 OHM 1% 0.25W	PHILIPS	2322 157 15119	02.221
R48-5	RESISTOR MF	1k0 OHM 5% 0.33W	PHILIPS	2322 180 73102	02.472
R49-5	RESISTOR MF	100 OHM 5% 0.33W	PHILIPS	2322 180 73101	02.448
R50-5	RESISTOR ARRAY	4x100 OHM 5% 1/8W	PANASONIC	EXBF8V1016 (4X100R)	08.602
R52-5	RESISTOR MF	22k1 OHM 1% 0.25W	PHILIPS	2322 157 12213	02.234
R53-5	RESISTOR MF	5k11 OHM 1% 0.25W	PHILIPS	2322 157 15112	02.228
R56-5	RESISTOR MF	10k OHM 5% 0.33W	PHILIPS	2322 180 73103	02.496
R59-5	RESISTOR ARRAY	4x100 OHM 5% 1/8W	PANASONIC	EXBF8V1016 (4X100R)	08.602
R60-5	RESISTOR ARRAY	4x100 OHM 5% 1/8W	PANASONIC	EXBF8V1016 (4X100R)	08.602
R61-5	RESISTOR MF	100 OHM 5% 0.33W	PHILIPS	2322 180 73101	02.448
R62-5	RESISTOR	22 OHM 5% 0.5W	PHILIPS	2322 156 12709	03.160
U1-5	INTEGRATED CIRCUIT	4-BIT BIN.UP/DOWN COUNTER	TEXAS	SN74HC191N	34.535
U2-5	INTEGRATED CIRCUIT	DUAL D-FF POS.TRIG.	TEXAS	SN74HC74N	34.501
U3-5	INTEGRATED CIRCUIT	QUAD 2-INPUT NAND GATE	TEXAS	SN74HC00N	34.515
U4-5	INTEGRATED CIRCUIT	OCTAL BUFF.& LINE DRIVERS	TEXAS	SN74HC541N	34.510
U5-5	EEPROM	8kx8 250nS Access Time	SEEQ	PQ 28C64-250	32.600
U7-5	MASTER PROCESSOR UNIT	8 BIT SERIAL INTERFACE	HITACHI	HD630D3YP	32.575
U9-5	DECODER	4 LINE TO 16 LINE DECODER	TEXAS	SN74HC154NT	34.505
U10-5	INTEGRATED CIRCUIT	HEX INVERTERS	TEXAS	SN74HC04N	34.520
U12-5	INTEGRATED CIRCUIT	DUAL OPERATIONAL AMP.	TEXAS	MC1458P	31.215
U13-5	INTEGRATED CIRCUIT	QUAD 2-INPUT NAND GATE	TEXAS	SN74HC00N	34.515
U15-5	uC SUPERVISORY CIRCUIT	MAX 690	MAXIM	MAX 690 CPA	32.585
U16-5	VOLTAGE REGULATOR	5V 5% 0.1A (LOW DROPOUT)	MOTOROLA	LM2931AZ-5.0	31.134
U17-5	VOLTAGE REGULATOR	FIXED 5V/1A	MOTOROLA	MC7805CT	31.250
U18-5	VOLTAGE REGULATOR	FIXED -5V/1A	MOTOROLA	MC7905CT	31.071
U19-5	INTEGRATED CIRCUIT	OCTAL BUFF.& LINE DRIVERS	TEXAS	SN74HC541N	34.510
U20-5	INTEGRATED CIRCUIT	TRIPLE 3-INPUT NOR GATE	TEXAS	SN74HC27N	34.516
X1-5	CRYSTAL C1081A	8.005MHZ HC-18/U	DANTRONIC	SP.SPFC: C1081A	39.820

POSITION	DESCRIPTION		MANUFACTOR	TYPE	S.P.NUMBER
	KEYBOARD MODULE 6	RE2100/C2140	ESPERA	5-0-25636E	625636
D1-6	DIODE LIGHT EMITTING	SUB MINIATURE YELLOW	H.P.	HLMP-7019	25.649
D2-6	DIODE LIGHT EMITTING	SUB MINIATURE YELLOW	H.P.	HLMP-7019	25.649
D3-6	DIODE LIGHT EMITTING	SUB MINIATURE YELLOW	H.P.	HLMP-7019	25.649
D4-6	DIODE LIGHT EMITTING	SUB MINIATURE YELLOW	H.P.	HLMP-7019	25.649
D5-6	DIODE LIGHT EMITTING	SUB MINIATURE YELLOW	H.P.	HLMP-7019	25.649
D6-6	DIODE LIGHT EMITTING	SUB MINIATURE YELLOW	H.P.	HLMP-7019	25.649
D7-6	DIODE LIGHT EMITTING	SUB MINIATURE YELLOW	H.P.	HLMP-7019	25.649
D8-6	DIODE LIGHT EMITTING	SUB MINIATURE YELLOW	H.P.	HLMP-7019	25.649
D9-6	DIODE LIGHT EMITTING	SUB MINIATURE YELLOW	H.P.	HLMP-7019	25.649
D10-6	DIODE LIGHT EMITTING	SUB MINIATURE YELLOW	H.P.	HLMP-7019	25.649
D11-6	DIODE LIGHT EMITTING	SUB MINIATURE YELLOW	H.P.	HLMP-7019	25.649
D12-6	DIODE LIGHT EMITTING	SUB MINIATURE YELLOW	H.P.	HLMP-7019	25.649
D13-6	DIODE LIGHT EMITTING	SUB MINIATURE YELLOW	H.P.	HLMP-7019	25.649
J1-6	SOCKET	2x7 POLES	AMP	1-215079-4	78.196
R1-6	RESISTOR MF	330 OHM 5% 0.33W	PHILIPS	2322 180 73331	02.460
R2-6	RESISTOR MF	680 OHM 5% 0.33W	PHILIPS	2322 180 73681	02.468
R3-6	RESISTOR MF	680 OHM 5% 0.33W	PHILIPS	2322 180 73681	02.468
R4-6	RESISTOR MF	330 OHM 5% 0.33W	PHILIPS	2322 180 73331	02.460
R5-6	RESISTOR MF	330 OHM 5% 0.33W	PHILIPS	2322 180 73331	02.460
S1-6	SWITCH KEYBOARD	12x12mm	ALPS	SKHCAD (KHC 10904)	43.601
S2-6	SWITCH KEYBOARD	12x12mm	ALPS	SKHCAD (KHC 10904)	43.601
S3-6	SWITCH KEYBOARD	12x12mm	ALPS	SKHCAD (KHC 10904)	43.601
S4-6	SWITCH KEYBOARD	12x12mm	ALPS	SKHCAD (KHC 10904)	43.601
S5-6	SWITCH KEYBOARD	12x12mm	ALPS	SKHCAD (KHC 10904)	43.601
S6-6	SWITCH KEYBOARD	12x12mm	ALPS	SKHCAD (KHC 10904)	43.601
S7-6	SWITCH KEYBOARD	12x12mm	ALPS	SKHCAD (KHC 10904)	43.601
S8-6	SWITCH KEYBOARD	12x12mm	ALPS	SKHCAD (KHC 10904)	43.601
S9-6	SWITCH KEYBOARD	12x12mm	ALPS	SKHCAD (KHC 10904)	43.601
S10-6	SWITCH KEYBOARD	12x12mm	ALPS	SKHCAD (KHC 10904)	43.601
S11-6	SWITCH KEYBOARD	12x12mm	ALPS	SKHCAD (KHC 10904)	43.601
S12-6	SWITCH KEYBOARD	12x12mm	ALPS	SKHCAD (KHC 10904)	43.601
S13-6	SWITCH KEYBOARD	12x12mm	ALPS	SKHCAD (KHC 10904)	43.601
S14-6	SWITCH KEYBOARD	12x12mm	ALPS	SKHCAD (KHC 10904)	43.601
S15-6	SWITCH KEYBOARD	12x12mm	ALPS	SKHCAD (KHC 10904)	43.601
S16-6	SWITCH KEYBOARD	12x12mm	ALPS	SKHCAD (KHC 10904)	43.601
S17-6	SWITCH KEYBOARD	12x12mm	ALPS	SKHCAD (KHC 10904)	43.601
S18-6	SWITCH KEYBOARD	12x12mm	ALPS	SKHCAD (KHC 10904)	43.601
S19-6	SWITCH KEYBOARD	12x12mm	ALPS	SKHCAD (KHC 10904)	43.601
S20-6	SWITCH KEYBOARD	12x12mm	ALPS	SKHCAD (KHC 10904)	43.601
S21-6	SWITCH KEYBOARD	12x12mm	ALPS	SKHCAD (KHC 10904)	43.601
S22-6	SWITCH KEYBOARD	12x12mm	ALPS	SKHCAD (KHC 10904)	43.601

POSITION	DESCRIPTION		MANUFACTOR	TYPE	S.P.NUMBER
S23-6	SWITCH KEYBOARD	12x12mm	ALPS	SKHCAD (KHC 10904)	43.601
S24-6	SWITCH KEYBOARD	12x12mm	ALPS	SKHCAD (KHC 10904)	43.601
S25-6	SWITCH KEYBOARD	12x12mm	ALPS	SKHCAD (KHC 10904)	43.601
S26-6	SWITCH KEYBOARD	12x12mm	ALPS	SKHCAD (KHC 10904)	43.601

RE2100 35/91

POSITION	DESCRIPTION		MANUFACTOR	TYPE	S.P. NUMBER
	DISPLAY MODULE 7	RL2100/C2140	FSPFRA	5-0-25637D	625637
C1-7	CAPACITOR ELECTROLYTIC	2u2F 20% 50VDC	ERO	EK1 00 AA 12? H M9	14.503
C2-7	CAPACITOR CERAMIC	10nF -20/+80% 50VDC CL2	KEMET	C 317 C 103 Z 5U5CA-C7301	16.302
C3-7	CAPACITOR CERAMIC	1n0F 20% 100VDC CL2	KEMET	C 317 C 102 M 1R5CA-C7301	16.300
C4-7	CAPACITOR CERAMIC	1n0F 20% 100VDC CL2	KEMET	C 317 C 102 M 1R5CA-C7301	16.300
C5-7	CAPACITOR CERAMIC	1n0F 20% 100VDC CL2	KEMET	C 317 C 102 M 1R5CA-C7301	16.300
C6-7	CAPACITOR CERAMIC	10nF -20/+80% 50VDC CL2	KEMET	C 317 C 103 Z 5U5CA-C7301	16.302
C7-7	CAPACITOR CERAMIC	10nF -20/+80% 50VDC CL2	KEMET	C 317 C 103 Z 5U5CA-C7301	16.302
C8-7	CAPACITOR CERAMIC	10nF -20/+80% 50VDC CL2	KEMET	C 317 C 103 Z 5U5CA-C7301	16.302
D1-7	DIODE	1N4148 HIGH SPEED	PHILIPS	1N4148-143	25.131
D3-7	DIODE LIGHT EMITTING	Ø3mm RED LOW CURRENT	H.P.	HLMP-K150-OPTION 002	25.662
D4-7	DIODE LIGHT EMITTING	Ø3mm RED LOW CURRENT	H.P.	HLMP-K150-OPTION 002	25.662
D5-7	DIODE LIGHT EMITTING	Ø3mm RED LOW CURRENT	H.P.	HLMP-K150-OPTION 002	25.662
D6-7	DIODE LIGHT EMITTING	Ø5mm RED LOW CURRENT	H.P.	HLMP-D155-OPTION 002	25.665
D7-7	DIODE LIGHT EMITTING	Ø5mm RED LOW CURRENT	H.P.	HLMP-D155-OPTION 002	25.665
D8-7	DIODE LIGHT EMITTING	Ø5mm RED LOW CURRENT	H.P.	HLMP-D155-OPTION 002	25.665
D9-7	DIODE LIGHT EMITTING	Ø5mm RED LOW CURRENT	H.P.	HLMP-D155-OPTION 002	25.665
D10-7	DIODE LIGHT EMITTING	Ø5mm RED LOW CURRENT	H.P.	HLMP-D155-OPTION 002	25.665
D11-7	DIODE LIGHT EMITTING	Ø5mm RED LOW CURRENT	H.P.	HLMP-D155-OPTION 002	25.665
D12-7	DIODE LIGHT EMITTING	Ø5mm RED LOW CURRENT	H.P.	HLMP-D155-OPTION 002	25.665
D13-7	DIODE LIGHT EMITTING	Ø5mm RED LOW CURRENT	H.P.	HLMP-D155-OPTION 002	25.665
D14-7	DIODE LIGHT EMITTING	Ø5mm RED LOW CURRENT	H.P.	HLMP-D155-OPTION 002	25.665
D15-7	DIODE ZENER	5V6 5% 0.4W	PHILIPS	BZX79C5V6	26.530
D16-7	DIODE	1N4148 HIGH SPEED	PHILIPS	1N4148-143	25.131
D17-7	DIODE	1N4148 HIGH SPEED	PHILIPS	1N4148-143	25.131
J1-7	SOCKET	2x3 POLES	AMP	0-215079-6	78.192
J2-7	SOCKET	2x7 POLES	AMP	1-215079-4	78.196
Q1-7	TRANSISTOR AF	BC558B	PHILIPS	BC558B	28.100
Q2-7	TRANSISTOR AF	BC558B	PHILIPS	BC558B	28.100
Q3-7	TRANSISTOR AF	BC558B	PHILIPS	BC558B	28.100
Q4-7	TRANSISTOR AF	BC558B	PHILIPS	BC558B	28.100
Q5-7	TRANSISTOR AF	BC558B	PHILIPS	BC558B	28.100
R1-7	RESISTOR MF	10k OHM 5% 0.33W	PHILIPS	2322 180 73103	02.496
R2-7	RESISTOR MF	10k OHM 5% 0.33W	PHILIPS	2322 180 73103	02.496
R3-7	POTENTIOMETER	100k OHM 20% 0.2W LIN.	NOBLE	779-9013-B	08.282
R4-7	POTENTIOMETER	10k OHM 10% 0.1W LOG	NOBLE	V90-10155-D	08.257
R5-7	RESISTOR MF	10k OHM 5% 0.33W	PHILIPS	2322 180 73103	02.496
R6-7	RESISTOR MF	4k7 OHM 5% 0.33W	PHILIPS	2322 180 73472	02.488
R7-7	RESISTOR MF	27k OHM 5% 0.33W	PHILIPS	2322 180 73273	02.506
R8-7	RESISTOR MF	1k8 OHM 5% 0.33W	PHILIPS	2322 180 73182	02.478
R9-7	RESISTOR MF	12k OHM 5% 0.33W	PHILIPS	2322 180 73123	02.498
R10-7	RESISTOR MF	1k8 OHM 5% 0.33W	PHILIPS	2322 180 73182	02.478

POSITION	DESCRIPTION		MANUFACTOR	TYPE	S.P. NUMBER
R11-7	RESISTOR MF	820 OHM 5% 0.33W	PHILIPS	2322 180 73821	02.470
R12-7	RESISTOR MF	2k7 OHM 5% 0.33W	PHILIPS	2322 180 73272	02.482
R13-7	RESISTOR MF	4k7 OHM 5% 0.33W	PHILIPS	2322 180 73472	02.488
R14-7	RESISTOR MF	4k7 OHM 5% 0.33W	PHILIPS	2322 180 73472	02.488
R15-7	RESISTOR MF	82k OHM 5% 0.33W	PHILIPS	2322 180 73823	02.518
R16-7	RESISTOR MF	56k OHM 5% 0.33W	PHILIPS	2322 180 73563	02.514
R17-7	RESISTOR MF	8k2 OHM 5% 0.33W	PHILIPS	2322 180 73822	02.494
R18-7	RESISTOR MF	8k2 OHM 5% 0.33W	PHILIPS	2322 180 73822	02.494
R19-7	RESISTOR MF	8k2 OHM 5% 0.33W	PHILIPS	2322 180 73822	02.494
U1-7	LED BAR GRAPH ARRAY	RED 10-ELEMENTS	H.P.	HLCP-J100	25.800
U2-7	LED BAR DISPLAY DRIVFR	LM3914	NATIONAL	LM3914N	32.790
U3-7	LED DISPLAY DRIVERS	M5450	NATIONAL	MM5450	32.826
U4-7	LED DISPLAY DRIVERS	M5450	NATIONAL	MM5450	32.826
U5-7	LED DISPLAY DRIVERS	M5450	NATIONAL	MM5450	32.826
U6-7	INTEGRATED CIRCUIT	8 BIT SHIFT REG.SERIAL IO	NATIONAL	MM74HC595N	34.502
U7-7	DUAL OP AMP	LM358N	TEXAS	LM358P	31.100
U8-7	DISPLAY LED	7 SEGMENT RED H=7mm	TELEFUNKEN	TDSL 1150	25.726
U9-7	DISPLAY LED	7 SEGMENT RED H=7mm	TELEFUNKEN	TDSL 1150	25.726
U10-7	DISPLAY LED	7 SEGMENT RED H=7mm	TELEFUNKEN	TDSL 1150	25.726
U11-7	DISPLAY LED	7 SEGMENT RED H=7mm	TELEFUNKEN	TDSL 1150	25.726
U12-7	DISPLAY LED	7 SEGMENT RED H=7mm	TELEFUNKEN	TDSL 1150	25.726
U13-7	DISPLAY LED	7 SEGMENT RED H=7mm	TELEFUNKEN	TDSL 1150	25.726
U14-7	DISPLAY LED	7 SEGMENT RED H=7mm	TELEFUNKEN	TDSL 1150	25.726
U15-7	DISPLAY LED	7 SEGMENT RED H=7mm	TELEFUNKEN	TDSL 1150	25.726
U16-7	DISPLAY LED	7 SEGMENT RED H=7mm	TELEFUNKEN	TDSL 1150	25.726
U17-7	DISPLAY LED	7 SEGMENT RED H=7mm	TELEFUNKEN	TDSL 1150	25.726
U18-7	DISPLAY LED	7 SEGMENT RED H=7mm	TELEFUNKEN	TDSL 1150	25.726
U19-7	DISPLAY LED	7 SEGMENT RED H=7mm	TELEFUNKEN	TDSL 1150	25.726
U20-7	DISPLAY LED	7 SEGMENT RED H=7mm	TELEFUNKEN	TDSL 1150	25.726

RE2100 35/91



POSITION	DESCRIPTION		MANUFACTOR	TYPE	S.P.NUMBER
	POWLR MODULE 8	RE2100	ESPERA	5-0-25638C	625638
C1-8	CAPACITOR MKT	0.1uF 10% 63VDC	PHILIPS	2222 370 78104	11.136
C2-8	CAPACITOR MKT	0.1uF 10% 63VDC	PHILIPS	2222 370 78104	11.136
C3-8	CAPACITOR CERAMIC	10nF -20/+80% CL2 50VDC	KCK	RT-HE70 SK YF 103 Z AMMO PACK	15.170
C4-8	CAPACITOR ELECTROLYTIC	10uF 20% 35VDC	ERO	EKI 00 AA 210 F M9	14.512
C5-8	CAPACITOR CERAMIC	10nF -20/+80% CL2 50VDC	KCK	RT-HE70 SK YF 103 Z AMMO PACK	15.170
C6-8	CAPACITOR MKT	220nF 20% 63VDC	ERO	MKT 1826-422/06 6-G	11.183
C7-8	CAPACITOR CERAMIC	10nF -20/+80% CL2 50VDC	KCK	RT-HE70 SK YF 103 Z AMMO PACK	15.170
C8-8	CAPACITOR CERAMIC	10nF -20/+80% CL2 50VDC	KCK	RT-HE70 SK YF 103 Z AMMO PACK	15.170
C9-8	CAPACITOR ELECTROLYTIC	10uF 20% 35VDC	ERO	EKI 00 AA 210 F M9	14.512
C10-8	CAPACITOR ELECTROLYTIC	10uF 20% 35VDC	ERO	EKI 00 AA 210 F M9	14.512
C11-8	CAPACITOR MKT	0.1uF 10% 63VDC	PHILIPS	2222 370 78104	11.136
C12-8	CAPACITOR MKT	220nF 20% 63VDC	ERO	MKT 1826-422/06 6-G	11.183
C13-8	CAPACITOR MKT	0.1uF 10% 63VDC	PHILIPS	2222 370 78104	11.136
C14-8	CAPACITOR ELECTROLYTIC	10uF 20% 35VDC	ERO	EKI 00 AA 210 F M9	14.512
C15-8	CAPACITOR CERAMIC	10nF -20/+80% CL2 50VDC	KCK	RT-HE70 SK YF 103 Z AMMO PACK	15.170
C16-8	CAPACITOR POLYSTYRENE	75pOF 1% 630VDC	PHILIPS	2222 431 87509	10.397
C17-8	CAPACITOR MKT	220nF 20% 63VDC	ERO	MKT 1826-422/06 6-G	11.183
C18-8	CAPACITOR POLYSTYRENE	150pF 1% 630VDC	PHILIPS	2222 431 81301	10.404
C19-8	CAPACITOR MKT	0.1uF 10% 63VDC	PHILIPS	2222 370 78104	11.136
C20-8	CAPACITOR POLYSTYRENE	68pOF 1% 630VDC	PHILIPS	2222 431 86809	10.396
C21-8	CAPACITOR POLYSTYRENE	68pOF 1% 630VDC	PHILIPS	2222 431 86809	10.396
C22-8	CAPACITOR MKT	0.1uF 10% 63VDC	PHILIPS	2222 370 78104	11.136
C24-8	CAPACITOR POLYSTYRENE	130pF 1% 630VDC	PHILIPS	2222 431 81301	10.404
C25-8	CAPACITOR ELECTROLYTIC	10uF 20% 35VDC	ERO	EKI 00 AA 210 F M9	14.512
C26-8	CAPACITOR CERAMIC	10nF -20/+80% CL2 50VDC	KCK	RT-HE70 SK YF 103 Z AMMO PACK	15.170
C27-8	CAPACITOR POLYSTYRENE	75pOF 1% 630VDC	PHILIPS	2222 431 87509	10.397
C28-8	CAPACITOR MKT	0.1uF 10% 63VDC	PHILIPS	2222 370 78104	11.136
C29-8	CAPACITOR MKT	220nF 20% 63VDC	ERO	MKT 1826-422/06 6-G	11.183
C30-8	CAPACITOR MKT	220nF 20% 63VDC	ERO	MKT 1826-422/06 6-G	11.183
C31-8	CAPACITOR ELECTROLYTIC	10uF 20% 35VDC	ERO	EKI 00 AA 210 F M9	14.512
C32-8	CAPACITOR MKT	0.1uF 10% 63VDC	PHILIPS	2222 370 78104	11.136
C33-8	CAPACITOR CERAMIC	18pF 5% NPO 500VDC	NKE	DT 360 758S CH 180 J 500V FLAT PACK	15.060
C34-8	CAPACITOR MKT	220nF 20% 63VDC	ERO	MKT 1826-422/06 6-G	11.183
C35-8	CAPACITOR MKT	0.1uF 10% 63VDC	PHILIPS	2222 370 78104	11.136

POSITION	DESCRIPTION		MANUFACTOR	TYPE	S.P.NUMBER
C36-8	CAPACITOR MKT	0.1uF 10% 63VDC	PHILIPS	2222 370 78104	11.136
C37-8	CAPACITOR CERAMIC	10nF -20/+80% CL2 50VDC	KCK	RT-HE70 SK YF 103 Z AMMO PACK	15.170
C38-8	CAPACITOR MKT	0.1uF 10% 63VDC	PHILIPS	2222 370 78104	11.136
D1-8	DIODE RECTIFIFR	1N4002 100V/1A	THOMSON	1N4002 (03/04/05/06/07)	25.100
D2-8	DIODE ZENFR	9V1 5% 0.4W	PHILIPS	BZX79C9V1	26.546
D3-8	DIODE RECTIFIER	1N4002 100V/1A	THOMSON	1N4002 (03/04/05/06/07)	25.100
D4-8	DIODE RECTIFIER	1N4002 100V/1A	THOMSON	1N4002 (03/04/05/06/07)	25.100
D5-8	DIODE RECTIFIER	1N4002 100V/1A	THOMSON	1N4002 (03/04/05/06/07)	25.100
D7-8	DIODE RECTIFIER	1N4002 100V/1A	THOMSON	1N4002 (03/04/05/06/07)	25.100
D8-8	DIODE RECTIFIER	1N4002 100V/1A	THOMSON	1N4002 (03/04/05/06/07)	25.100
L1-8	CHOKE FIXED	10uH 5%	NEOSID	00 6122 00 AMMO PACK	20.118
L2-8	CHOKE FIXED	10uH 5%	NEOSID	00 6122 00 AMMO PACK	20.118
L3-8	CHOKE FIXED	10uH 5%	NEOSID	00 6122 00 AMMO PACK	20.118
L4-8	CHOKE FIXED	2u7H 10%	FASTRON	MICC-2R7K-02	20.352
L5-8	CHOKE FIXED	1u2H 10%	FASTRON	MICC-1R2K-02	20.348
L6-8	CHOKE FIXED	1u2H 10%	FASTRON	MICC-1R2K-02	20.348
L7-8	CHOKE FIXED	680nH 10%	FASTRON	MICC-R68K-02	20.345
L8-8	CHOKE FIXED	680nH 10%	FASTRON	MICC-R68K-02	20.345
L9-8	CHOKE FIXED	1u2H 10%	FASTRON	MICC-1R2K-02	20.348
L10-8	CHOKE FIXED	1u2H 10%	FASTRON	MICC-1R2K-02	20.348
L11-8	CHOKE FIXED	10uH 5%	NEOSID	00 6122 00 AMMO PACK	20.118
L12-8	CHOKE FIXED	10uH 5%	NEOSID	00 6122 00 AMMO PACK	20.118
L13-8	CHOKE FIXED	680nH 10%	FASTRON	MICC-R68K-02	20.345
P1-8	PLUG	2x5 POLES	3M	3654-6002	78.251
P2-8	PLUG	2x5 POLES	3M	3654-6002	78.251
P3-8	SOCKET COAX	HORISONTAL FOR PCB MOUNT.	TAIKO	TMP-J01X-A2	78.517
P4-8	SOCKET COAX	HORISONTAL FOR PCB MOUNT.	TAIKO	TMP-J01X-A2	78.517
Q1-8	TRANSISTOR AF	BC548 NPN T0-92	PHILIPS	BC548 (-A/-B/-C)	28.070
Q2-8	TRANSISTOR AF	BC558 PNP T0-92	PHILIPS	BC558 (-A/-B/-C)	28.095
Q3-8	TRANSISTOR RF	BFW17A PNP T0-39	PHILIPS	BFW17A	29.151
Q4-8	TRANSISTOR RF	BFW17A PNP T0-39	PHILIPS	BFW17A	29.151
Q5-8	TRANSISTOR RF	BFW17A PNP T0-39	PHILIPS	BFW17A	29.151
R1-8	RESISTOR MF	15k OHM 5% 0.33W	PHILIPS	2322 180 73153	02.500
R2-8	RESISTOR MF	8k2 OHM 5% 0.33W	PHILIPS	2322 180 73822	02.494
R3-8	RESISTOR MF	2k2 OHM 5% 0.33W	PHILIPS	2322 180 73222	02.480
R4-8	RESISTOR MF	200 OHM 5% 0.33W	PHILIPS	2322 180 73201	02.455
R5-8	RESISTOR MF	10k OHM 5% 0.33W	PHILIPS	2322 180 73103	02.496
R6-8	RESISTOR MF	2k2 OHM 5% 0.33W	PHILIPS	2322 180 73222	02.480

POSITION	DESCRIPTION		MANUFACTURER	TYPE	S.P. NUMBER
R7-8	RESISTOR MF	200 OHM 5% 0.33W	PHILIPS	2322 180 73201	02.455
R8-8	RESISTOR MF	22 OHM 5% 0.4W	PHILIPS	2322 181 53229	01.158
R9-8	RESISTOR MF	470 OHM 5% 0.33W	PHILIPS	2322 180 73471	02.464
R10-8	RESISTOR MF	220 OHM 5% 0.33W	PHILIPS	2322 180 73221	02.456
R11-8	RESISTOR MF	1k2 OHM 5% 0.33W	PHILIPS	2322 180 73122	02.474
R12-8	RESISTOR MF	39 OHM 5% 0.33W	PHILIPS	2322 180 73399	02.438
R13-8	RESISTOR MF	120 OHM 5% 0.33W	PHILIPS	2322 180 73121	02.450
R14-8	RESISTOR MF	10 OHM 5% 0.33W	PHILIPS	2322 180 73109	02.424
R15-8	RESISTOR MF	27 OHM 5% 0.4W	PHILIPS	2322 181 53279	01.160
R16-8	RESISTOR PMF	150 OHM 5% 2W	PHILIPS	2322 194 13151	04.179
R17-8	RESISTOR MF	226 OHM 1% 0.25W	PHILIPS	2322 157 12261	02.213
R18-8	RESISTOR MF	560 OHM 5% 0.33W	PHILIPS	2322 180 73561	02.466
R19-8	RESISTOR MF	91 OHM 5% 0.33W	PHILIPS	2322 180 73919	02.447
R20-8	RESISTOR MF	2k0 OHM 5% 0.4W	PHILIPS	2322 181 53202	01.207
R21-8	RESISTOR MF	12 OHM 5% 0.4W	PHILIPS	2322 181 53129	01.152
R22-8	RESISTOR MF	270 OHM 5% 0.4W	PHILIPS	2322 181 53271	01.185
R23-8	RESISTOR MF	27 OHM 5% 0.33W	PHILIPS	2322 180 73279	02.434
R24-8	RESISTOR MF	360 OHM 5% 0.33W	PHILIPS	2322 180 73361	02.461
R25-8	RESISTOR MF	200 OHM 5% 0.33W	PHILIPS	2322 180 73201	02.455
R26-8	RESISTOR MF	470 OHM 5% 0.33W	PHILIPS	2322 180 73471	02.464
R27-8	RESISTOR MF	1k2 OHM 5% 0.33W	PHILIPS	2322 180 73122	02.474
R28-8	RESISTOR MF	2k2 OHM 5% 0.4W	PHILIPS	2322 181 53222	01.208
R29-8	RESISTOR MF	33 OHM 5% 0.4W	PHILIPS	2322 181 53339	01.162
R30-8	PRESET CERMET (VERTICAL)	100 OHM 10% 0.5W	BOURNS	3386H-1-101	07.904
R31-8	RESISTOR MF	750 OHM 1% 0.25W	PHILIPS	2322 157 17501	02.240
R32-8	RESISTOR MF	22k1 OHM 1% 0.25W	PHILIPS	2322 157 12213	02.234
R33-8	RESISTOR MF	18k2 OHM 1% 0.25W	PHILIPS	2322 157 11823	02.233
TR1-8	TRANSFORMER	TL249	S.P. RADIO	6-0-21572	400249
TR2-8	TRANSFORMER	TL249	S.P. RADIO	6-0-21572	400249
U1-8	VOLTAGE REGULATOR	POSITIVE ADJUSTABLE 1.5A	MOTOROLA	LM317T	31.055
U2-8	VOLTAGE REGULATOR	NEGATIVE ADJUSTABLE 1.5A	MOTOROLA	LM337T	31.070
U3-8	VOLTAGE REGULATOR	FIXED 15V/1A	MOTOROLA	MC7815CT	31.090
U4-8	VOLTAGE REGULATOR	-15V 5% 0.1A	MOTOROLA	MC79L15ACP	31.143
U6-8	VOLTAGE REGULATOR	POSITIVE ADJUSTABLE 1.5A	MOTOROLA	LM317T	31.055
U7-8	VOLTAGE REGULATOR	POSITIVE ADJUSTABLE 1.5A	MOTOROLA	LM317T	31.055